



**AIR FORCE  
 ARMY TECHNICAL MANUAL  
 NAVY PUBLICATION  
 MARINE CORPS TECHNICAL MANUAL**

**T.O. 35C2-3-442-11  
 TM5-6115-600-12  
 NAVFAC P-8-628-12  
 TM-07464B-12**

**TECHNICAL MANUAL**

**OPERATOR AND ORGANIZATIONAL  
 MAINTENANCE MANUAL**

**GENERATOR SET, DIESEL ENGINE  
 DRIVEN, TACTICAL SKID MTD. 100KW.  
 3 PHASE, 4 WIRE, 120/208 AND 240/416  
 VOLTS**

DOD MODEL	CLASS	HERTZ	NSN
MEP007B	UTILITY	50/60	6115-01-036-6374

**INCLUDING OPTIONAL KITS**

DOD MODEL	NOMENCLATURE	NSN
MEP007BWF	WINTERIZATION KIT, FUEL BURNING	6115-01-131-7228
MEP007BWE	WINTERIZATION KIT, ELECTRIC	6115-01-125-9368
	WHEEL KIT ASSEMBLY	6115-01-135-6165

**THIS TECHNICAL MANUAL IS BEING PREPARED BY THE AUTOMATED TECHNICAL ORDER SYSTEM (ATOS). AS CHANGE PAGES ARE GENERATED THEY WILL REFLECT CURRENT SPECIFICATION REQUIREMENTS.**

**BASIC AND ALL CHANGES HAVE BEEN MERGED TO MAKE THIS A COMPLETE PUBLICATION**

DISTRIBUTION STATEMENT – Approved for public release; distribution is unlimited.  
 Other requests for this document shall be referred to WR-ALC/LKCB, Robins AFB GA 31098

Published under authority of the Secretary of the Air Force

**1 FEBRUARY 1982  
 CHANGE 8 - 8 JULY 1998**



## **WARNING**

### **NOISE HAZARD**

Operation of this equipment presents a noise hazard to personnel in the area. The noise level exceeds the allowable limits for unprotected personnel. Wear ear muffs or ear plugs which were fitted by a trained professional.

---

## **WARNING**

Corrosion prevention compound (MIL-C-16173) is flammable and slightly toxic. Avoid skin and eye contact or breathing of vapor. Eye, skin, and respiratory protection is required.

---

## **WARNING**

Compressed air used for cleaning or drying can create airborne particles that may enter the eyes. Pressure shall not exceed 30 psig (206 kPa). Wearing of goggles is required.

---

## **WARNING**

All cleaning compounds that meet MIL-C-87937 may be toxic. Avoid prolonged or repeated breathing of vapor or contact with skin. Avoid any contact with eyes. Safety glasses and protective gloves are required. Wash hands after use. Refer to applicable MSDS for additional information.

---

## **WARNING**

Welding operations produce heat, highly toxic fumes, injurious radiation, metal slag, and airborne particles. Welding goggles, the proper tinted lenses, apron or jacket, and welder's boots are required.

---

## **WARNING**

Engine must be cold when removing thermostat for testing. Failure to observe this precaution may result in second-or third-degree burns.

## WARNING

### HIGH VOLTAGE

is produced when this generator set is in operation.

---

## DEATH

or severe burns may result if personnel fail to observe safety precautions. Do not operate this generator set until the ground terminal stud has been connected to a suitable ground. Disconnect the battery ground cable before removing and installing components on the engine or in the electrical control panel system.

Do not attempt to service or otherwise make any adjustments, connections, or reconnections of wires or cables until generator set is shut down and completely de-energized.

---

## WARNING

### DANGEROUS GASES

Batteries generate explosive gas during charging; therefore, utilize extreme caution, do not smoke, or use open flame in vicinity when servicing batteries.

Slave receptacle is to be used when extra cranking power is required for starting unit. Other methods use not authorized.

Exhaust discharge contains noxious and deadly fumes. Do not operate generator sets in enclosed areas unless exhaust discharge is properly vented to the outside.

When filling fuel tank, maintain metal to metal contact between filler nozzle and fuel tank. Do not smoke or use an open flame in the vicinity.

---

## WARNING

### LIQUIDS UNDER PRESSURE

are generated as a result of operation of the generator set. Do not expose any part of the body to a high pressure leak in the fuel system of the generator set.

Relieve pressure from radiator before removing radiator cap.

### **WARNING**

Always maintain constant metal-to-metal contact between fuel tank filler neck and spout of fuel supply. This will prevent the possibility of sparking caused by static electricity.

---

### **WARNING**

Do not use a lifting device with a capacity of less than 10,000 pounds (4500 kg). Do not allow the generator set to swing while it is suspended. Failure to observe this warning may result in serious injury or death to personnel.

---

### **WARNING**

Do not operate the generator set in an enclosed area unless the exhaust gases are piped to the outside. Inhalation of exhaust fumes will result in serious injury.

---

### **WARNING**

Before attempting to connect load cables, make sure generator set is not operating and there is no input to the load.

---

### **WARNING**

Make sure generator set is not operating in a standby mode, or connected to a parallel bus when accomplishing voltage conversion. Death or injury may result.

---

### **WARNING**

Do not touch exposed electrical connections when DC CONTROL CIRCUIT BREAKER is energized.

### WARNING

The muffler and exhaust pipe become extremely hot during operation. Do not handle muffler or exhaust pipe when they are hot.

---

### WARNING

The breather tube and hose become extremely hot during generator set operation. Do not handle tube or hose while they are hot.

---

### WARNING

Do not perform this procedure while engine is running or during engine cool down after operation. Ensure that engine is cold before starting this procedure.

---

### WARNING

Disconnect a negative battery cable before performing any maintenance on the cooling system.

---

### WARNING

At least two people and/or a suitable lifting device will be needed to remove the front housing panel and radiator and shutter assembly.

---

### WARNING

Do not operate the generator set unless it has been properly grounded. Electrical faults (such as leakage paths) in the generator set, feeder lines, or load equipment can cause injury or death by electrocution.

### WARNING

Make sure kit power cable is removed  
from power supply.

---

### WARNING

Warning electrolyte contains sulfuric acid which can  
cause severe burns. It is highly toxic to the skin,  
eyes, and respiratory tract. Avoid all exposure. Skin,  
eye, and respiratory protection is required.

---

### WARNING

Drilling operation create metal chips that may enter  
the eye. Wearing of goggles is required.

---

### WARNING

Lacquer is flammable and moderately toxic to the skin,  
eyes, and respiratory tract. Skin, eye, and  
respiratory protection is required.

---

### WARNING

Do not attempt to remove the radiator cap until the  
radiator has cooled to a point where there will  
be no built-up steam pressure. Failure to  
observe this warning could result in second-or  
third-degree burns.

---

### WARNING

Solvent, Dry Cleaning P-D-680, Type II is flammable and moderately  
toxic to skin, eyes and respiratory tract. Eye and skin protection  
required. Good general ventilation is normally adequate.





**LIST OF EFFECTIVE PAGES**

NOTE: The portion of the text affected by the changes is indicated by a vertical line in the outer margins of the page. Changes to illustrations are indicated by miniature pointing hands. Changes to wiring diagrams are indicated by shaded areas.

**Dates of issue for original and changed pages are:**

Original .....	0.....	1 Feb 82	Change.....	6.....	2 Jul 93
Change.....	1.....	31 Jul 86	Change.....	7.....	19 Mar 97
Change.....	2.....	10 Mar 87	Change.....	8.....	8 Jul 98
Change.....	3.....	6 Dec 89			
Change.....	4.....	28 Jan 91			
Change.....	5.....	11 Feb 92			

**TOTAL NUMBER OF PAGES IN THIS PUBLICATION IS 362, CONSISTING OF THE FOLLOWING:**

Page No.	*Change No.	Page No.	*Change No.	Page No.	*Change No.
<b>Title</b> .....	<b>8</b>	3-20 .....	0	A-4 Blank .....	0
<b>A</b> .....	<b>8</b>	3-21 .....	1	B-1.....	1
<b>a</b> .....	<b>7</b>	3-22 Blank .....	1	B-2 - B-3 .....	0
<b>b</b> .....	<b>2</b>	4-1 - 4-12 .....	0	B-4.....	2
<b>c - d</b> .....	<b>0</b>	<b>4-13 - 4-14</b> .....	<b>8</b>	B-5 - B-7 .....	0
<b>e</b> .....	<b>1</b>	4-15 - 4-19 .....	0	B-8 Blank .....	0
<b>f Blank</b> .....	<b>1</b>	4-20 .....	1	C1 - C-3 .....	0
<b>i</b> .....	<b>0</b>	4-21 - 4-23 .....	0	C-4.....	2
<b>ii</b> .....	<b>2</b>	4-24 .....	2	C-5 - C-7 .....	0
<b>III - IV</b> .....	<b>8</b>	4-25 - 4-56 .....	0	C-8.....	1
<b>v - vi</b> .....	<b>0</b>	4-56A Added.....	7	C-9 - C-15 .....	0
<b>1-1</b> .....	<b>2</b>	4-56B Blank Added .....	7	C-16 Blank .....	0
<b>1-2</b> .....	<b>3</b>	4-57 .....	7	D-1 - D-2 Added.....	2
<b>1-3 - 1-31</b> .....	<b>0</b>	4-58 - 4-65 .....	0	Index 1 - 19 .....	0
<b>1-32</b> .....	<b>3</b>	4-66 .....	7	Index 20 Blank .....	0
<b>1-33 - 1-34</b> .....	<b>0</b>	4-66A Added.....	7	FO-1.....	0
<b>2-1 - 2-14</b> .....	<b>0</b>	4-66B Blank Added .....	7	FO-2.....	2
<b>2-15</b> .....	<b>2</b>	4-67 - 4-100 .....	0	FO-3 - FO-6.....	0
<b>2-16 - 2-20</b> .....	<b>0</b>	4-100A Added.....	7		
<b>2-21 - 2-22</b> .....	<b>4</b>	4-100B Blank Added .....	7		
<b>2-22A - 2-22B</b> .....	<b>0</b>	4-101 .....	7		
<b>2-23 - 2-26</b> .....	<b>0</b>	4-102 .....	0		
<b>2-27</b> .....	<b>3</b>	4-103 .....	2		
<b>2-28 - 2-30</b> .....	<b>0</b>	4-104 - 4-112 .....	0		
<b>2-31 Added</b> .....	<b>2</b>	4-113 - 4-114 .....	4		
<b>2-32 Blank Added</b> .....	<b>2</b>	4-114A Added.....	7		
<b>3-1 - 3-2</b> .....	<b>7</b>	4-114B Blank Added .....	7		
<b>3-3 - 3-4</b> .....	<b>4</b>	4-115.....	7		
<b>3-4A Added</b> .....	<b>2</b>	4-116 - 4-118 .....	0		
<b>3-4B Blank Added</b> .....	<b>2</b>	4-119.....	3		
<b>3-5</b> .....	<b>2</b>	4-120 - 4-135 .....	0		
<b>3-6</b> .....	<b>0</b>	4-136.....	6		
<b>3-7</b> .....	<b>1</b>	4-137 - 4-146 .....	0		
<b>3-8</b> .....	<b>0</b>	4-147 - 4-148 .....	5		
<b>3-9</b> .....	<b>2</b>	4-149 - 4-152 .....	0		
<b>3-10 - 3-17</b> .....	<b>0</b>	4-153.....	1		
<b>3-18</b> .....	<b>8</b>	4-154 - 4-155 .....	0		
<b>3-18A - 3-18C Added</b> .....	<b>8</b>	4-156 Blank.....	0		
<b>3-18D Blank Added</b> .....	<b>8</b>	5-1 - 5-36 .....	0		
<b>3-19</b> .....	<b>3</b>	A1 - A3.....	0		

\*Zero in this column indicates an original page



## Operator and Organizational Maintenance Manual

### GENERATOR SET, DIESEL ENGINE DRIVEN NSN 6115-01-036-6374

#### NOTE

An alphabetical index is located at the back of this manual.

### TABLE OF CONTENTS

			Paragraph	Page
CHAPTER	1.	INTRODUCTION		
Section	I.	General	1-1	1-1
	II.	Description and Data	1-9	1-3
CHAPTER	2.	OPERATING INSTRUCTIONS		
Section	I.	Operating procedures	2-1	2-1
	II.	Operation of auxiliary equipment	2-7	2-21
	III.	Operation under unusual conditions	2-10	2-26
CHAPTER	3.	OPERATOR/CREW MAINTENANCE INSTRUCTIONS		
Section	I.	Consumable operating and maintenance supplies	3-1	3-1
	II.	Lubrication instructions	3-2	3-2
	III.	Preventive maintenance checks and services	3-4	3-5
	IV.	Troubleshooting	3-6	3-8
	V.	Operator/Crew maintenance instructions	3-7	3-15
CHAPTER	4.	ORGANIZATIONAL MAINTENANCE		
Section	I.	Service upon receipt of equipment	4-1	4-1
	II.	Movement to a new work site	4-7	4-12
	III.	Repair parts; special tools; special test, measurement, and diagnostic equipment (TMDE); and special support equipment	4-8	4-13
	IV.	Lubrication instructions	4-10	4-13
	V.	Preventive maintenance checks and services	4-13	4-15
	VI.	Troubleshooting	4-15	4-21
	VII.	Radio interference suppression	4-16	4-38
	VIII.	Maintenance of housing	4-20	4-40
	IX.	Maintenance of DC electrical and control system	4-27	4-47
	X.	Maintenance of set controls and instrumentation	4-41	4-76
	XI.	Maintenance of AC electrical control system	4-68	4-95

## TABLE OF CONTENTS (Continued)

		Paragraph	Page
	XII. Maintenance of fuel system	4-83	4-108
	XIII. Maintenance of exhaust and breather system	4-95	4-122
	XIV. Maintenance of cooling system	4-99	4-125
	XV. Maintenance of lifting and support system	4-108	4-138
	XVI. Maintenance of power generation system	4-111	4-142
	XVII. Maintenance of engine	4-114	4-143
CHAPTER	5. AUXILIARY EQUIPMENT USED IN CONJUNCTION WITH THE END ITEM		
Section	I. Fuel burning winterization kit	5-1	5-1
	II. Electric winterization kit	5-22	5-21
APPENDIX	A. REFERENCES		A-1
APPENDIX	B. BASIC ISSUE ITEMS LIST AND MAINTENANCE AND OPERATING SUPPLIES		B-1
APPENDIX	C. MAINTENANCE ALLOCATION CHART		C-1
Section	I. Introduction		
	II. Maintenance Allocation Chart		
APPENDIX	D. ADDITIONAL AUTHORIZATION LIST		D-1
INDEX			Index-1

## LIST OF ILLUSTRATIONS

Figure	Title	Page
1-1	Generator Set, Right Front, Three Quarter View .....	1-4
1-2	Generator Set, Left Rear, Three Quarter View .....	1-5
1-3	Location of Identification Plates .....	1-28
1-4	Fuel System Diagram .....	1-29
1-5	Fault Indicator Panel A9, Schematic Diagram .....	1-30
1-6	Fuel Burning Winterization Kit, Wiring Diagram .....	1-31
1-7	Fuel Burning Winterization Kit, Schematic Diagram .....	1-32
1-8	Electric Winterization Kit, Wiring Diagram (2 Sheets) .....	1-32
1-9	Electric Winterization Kit, Schematic Diagram .....	1-34
2-1	Location of Controls, Instruments, and Receptacles .....	2-2
2-2	Control Cubicle, Controls and Indicators .....	2-6
2-3	Fault Indicator Panel, Controls .....	2-11
2-4	Voltage Conversion .....	2-14
2-5	Starting Generator Set Usual Conditions .....	2-15
2-6	Single Unit Operation .....	2-16

## LIST OF ILLUSTRATIONS - Continued

Figure	Title	Page
2-7	Starting Up for Parallel Operation (2 Sheets).....	2-18
2-8	Parallel Operation Connection Diagram.....	2-19
2-10	Stopping Generator Set Operation.....	2-21
2-11	Fuel Burning Winterization Kit, Controls and Indicators.....	2-22
2-12	Fuel Burning Winterization Kit, Operating Instructions.....	2-23
2-13	Electric Winterization Kit, Controls and Indicators.....	2-24
2-14	Electric Winterization Kit, Operating Instructions.....	2-25
2-15	Ether Starting, Operating Instructions.....	2-27
2-16	Emergency Operation (Battle Short) of Generator Set.....	2-30
3-1	Lubrication Order (2 Sheets).....	3-16
3-2	Batteries, Servicing.....	3-16
3-2A	Fuel Injection Pump Lever Puller Part Number: AR-MCSM 960005 (2 sheets).....	3-18
3-3	Fuel Filler Cap and Strainer.....	3-18
4-1	Shipping Crate.....	4-2
4-2	Location of Fill and Drain Points and Drain Valves.....	4-3
4-3	Noise Level Warning Sign.....	4-5
4-4	Installation Plan (2 Sheets).....	4-6
4-5	Ground Procedure.....	4-8
4-6	Fuel Connections.....	4-10
4-7	Load Cable Connections.....	4-11
4-8	Lubricating Oil Filter, Servicing.....	4-14
4-9	Radio Interference Suppression Components, Removal and Installation.....	4-39
4-10	Housing, Exploded View (2 Sheets).....	4-41
4-11	Installation of Door Seals.....	4-44
4-12	Tool Box, Removal and Replacement.....	4-46
4-13	Batteries and Rollo9ut Tray, Exploded View.....	4-52
4-14	Battery Cables and Slave Receptacles, Removal and Installation.....	4-54
4-15	Alternator and Fan Belts, Removal and Installation.....	4-55
4-16	Battery Charging Alternator, Test, Test and Adjustment.....	4-57
4-17	Battery Charging Alternator and Mounting Group, Removal and Installation.....	4-58
4-18	Wiring Harnesses, Removal and Installation (5 Sheets).....	4-60
4-19	Engine Electrical Control Elements. Removal and Installation (2 Sheets).....	4-67
4-20	Electronic Component Assembly A27, Relay Removal and Installation.....	4-70
4-21	DC Control Circuit Breaker, Removal and Installation.....	4-71
4-22	Starter and Solenoid, Test.....	4-72
4-23	Starter and Solenoid, Removal and Installation.....	4-73
4-24	Starter Drive Assembly, Pinion Clearance Adjustment.....	4-74
4-25	Fuel Shutdown Solenoid L1, Exploded View.....	4-75
4-26	FAULT INDICATOR Assembly A9, Exploded View.....	4-77
4-27	FAULT INDICATOR Assembly A9, Test Setup.....	4-78
4-28	Typical Meter, Removal and Replacement.....	4-83
4-29	VOLTAGE ADJUST Rheostat R2, Removal and Replacement.....	4-83
4-30	Hertz Meter M6 and Frequency Transducer A2, Removal and Replacement.....	4-85
4-31	Toggle Switches, Removal and Replacement.....	4-85
4-32	AMPS-VOLTS Selector Switch S8, Simplified Schematic Diagram.....	4-85
4-33	AMPS-VOLTS Selector Switch S8, Removal and Replacement.....	4-85
4-34	Panel Lights, Removal and Replacement.....	4-86
4-35	Indicator Lights, Removal and Replacement.....	4-86
4-36	Gage (Typical), Test Setup.....	4-87
4-37	Gage (Typical), Removal and Replacement.....	4-88

## LIST OF ILLUSTRATIONS - Continued

Figure	Title	Page
4-38	Manual Speed Control, Removal and Installation .....	4-90
4-39	Reconnection Board Assembly and Load Board Assembly, Removal and Installation .....	4-100
4-40	Reconnection Board Assembly, Exploded View .....	4-102
4-41	Circuit Breaker Assembly CB2, Removal and Installation .....	4-104
4-42	Convenience Receptacle Assembly, Exploded View .....	4-107
4-43	Electrical Fuel Transfer Pumps, Exploded View .....	4-100
4-44	Primary Fuel Filter and Strainer Assembly and Fuel Solenoid Valve, Explod- ed View .....	4-111
4-45	Secondary Fuel Filter, Service and Replacement .....	4-113
4-46	Fuel Level Switch and Day Tank, Exploded View .....	4-116
4-47	Ether System, Exploded View .....	4-118
4-48	Fuel Injection Lines, Removal and Replacement .....	4-120
4-49	Fuel Injection Valves, Removal and Replacement .....	4-121
4-50	Exhaust and Breather System, Exploded View .....	4-123
4-51	Radiator and Shutter Assembly .....	4-126
4-52	Shutter Control, Adjustment .....	4-129
4-53	Shutter Control Assembly, Exploded View .....	4-132
4-54	Water Pump, Removal .....	4-134
4-55	Coolant Thermostat, Replacement and Testing .....	4-135
4-56	Fan Belts, Adjustment and Replacement .....	4-137
4-57	Replacement of Lifting Frame .....	4-139
4-58	Replacement of Control Panel Supports .....	4-141
4-59	Generator Assembly, Inspection .....	4-143
4-60	Air Filters .....	4-144
4-61	Turbocharger Replacement .....	4-146
4-62	Governor Throttle Linkage, Adjustment and Replacement .....	4-147
4-63	Governor, Replacement .....	4-148
4-64	Fan Assembly, Replacement .....	4-149
4-65	Oil Cooler, Replacement .....	4-150
4-66	Idler Pulley Assembly, Inspection and Replacement .....	4-151
4-67	Exhaust Manifold, Removal and Installation .....	4-152
4-68	Valve Cover, Removal and Installation .....	4-154

## LIST OF ILLUSTRATIONS-Continued)

Figure	Title	Page
4-69	Valve Lash Adjustment .....	4-169
5-1	Fuel Burning Winterization Kit, Removal and Installation .....	5-2
	(2 Sheets)	
5-2	Fuel Burning Winterization Kit Heater Assembly, Service .....	5-11
5-3	Fuel Burning Winterization Kit Heater Assembly, Maintenance ....	5-12
5-4	Fuel Burning Winterization Kit, Igniter Replacement .....	5-14
5-5	Heater Control Box to Fuel Burning Heater, Wiring Harness .....	5-16
5-6	Special Relay Box to Fuel Burning Heater Control Box, .....	5-17
	Wiring Harness	
5-7	Fuel Burning Winterization Kit Control Box Assembly, .....	5-19
	Partially Exploded View	
5-8	Fuel Burning Winterization Kit Control Box, Lamp Replacement ...	5-20
5-9	Electric Winterization Kit, Removal and Installation .....	5-22
	(2 Sheets)	
5-10	Coolant Pump and Motor Assembly .....	5-31
5-11	Electric Heater, Exploded View .....	5-31
5-12	Control Box to Electric Heater, Wiring Harness .....	5-33
5-13	Electric Winterization Kit Control Box, Partially .....	5-35
	Exploded View	
F0-1	AC Troubleshooting Diagram	
F0-2	DC Troubleshooting Diagram	
F0-3	Generator Set Interconnection Diagram	
F0-4	AC Electrical System, Schematic Diagram	
F0-5	DC Electrical System, Schematic Diagram	
F0-6	Exciter-Regulator A11, Schematic Diagram	

## LIST OF TABLES

Table	Title	Page
1-1	Tabulated Data .....	1-6
1-2	Special Torque Data .....	1-29
2-1	Generator Set, Controls and Indicators .....	2-3
2-2	Control Cubicle, Controls and Indicators .....	2-6
2-3	Fault Indicator Panel, Controls and Indicators .....	2-11
2-4	Fuel Burning Winterization Kit, Control and Indicators .....	2-22A
2-5	Electric Winterization Kit, Controls and Indicators .....	2-24
3-1	Consumable Operating and Maintenance Supplies .....	3-1
3-2	Operator Preventive Maintenance Checks and Services .....	3-6
3-3	Troubleshooting, Operator .....	3-8
4-1	Freezing Points, Composition, and Specific Gravities of .....	4-4
	Military Antifreeze Material	
4-2	Organizational Preventive Maintenance Checks and Services .....	4-16
4-3	Troubleshooting, Organizational .....	4-22
4-4	Fault Indicator Assembly A9, Procedural Analysis .....	4-80
5-1	Fuel Burning Winterization Kit, Operator/Crew Preventive .....	5-5
	Maintenance Checks and Services	
5-2	Fuel Burning Winterization Kit, Organizational Preventive .....	5-6
	Maintenance Checks and Services	
5-3	Fuel Burning Winterization Kit, Operator/Crew Troubleshooting ..	5-8
5-4	Fuel Burning Winterization Kit, Organizational .....	5-9
	Troubleshooting	
5-5	Electric Winterization Kit, Operator/Crew Preventive .....	5-25
	Maintenance Checks and Services	
5-6	Electric Winterization Kit, Organizational Preventive .....	5-26
	Maintenance Checks and Services	
5-7	Electric Winterization Kit, Operator/Crew Troubleshooting .....	5-27
5-8	Electric Winterization Kit, Organizational Troubleshooting .....	5-28



## CHAPTER 1 INTRODUCTION

### Section I. GENERAL

1-1. SCOPE. This manual contains instructions for use in operating and maintaining the 100 KW Diesel Engine Driven Generator Set, Model MEP007B. The 50/60 Hertz Utility (Mode I, Class 1) set is used in applications where precise power is not required. These instructions cover operation, lubrication, maintenance, and preventive maintenance checks and services. The maintenance procedures described herein are within the scope of the operator and organizational maintenance personnel as allocated by the Maintenance Allocation Chart (MAC). These procedures are for the generator set, its accessories, and auxiliaries.

1-2. LIMITED APPLICABILITY. Some portions of this publication are not applicable to all services. These portions are prefixed to indicate the services to which they pertain: (F) for Air Force, (A) for Army, (N) for Navy, and (MC) for Marine Corps. Portions not prefixed are applicable to all services.

1-3. MAINTENANCE FORMS AND RECORDS. The forms and records used for maintenance purposes by the various services are specified as follows:

- a. (F) Maintenance forms and records used by Air Force personnel are prescribed in AFM-66-1 and the applicable 00-20 Series Technical Orders.
- b. (A) Maintenance forms and records used by Army personnel are prescribed by TM 38-750.
- c. (N) Navy users should refer to their service peculiar directives to determine applicable maintenance forms and records to be used.

d. (MC) Maintenance forms and records used by Marine Corps personnel are prescribed by TM 4700-15/1.

1-4. REPORTING OF ERRORS. Reporting of errors, omissions, and recommendations for improvement of this publication by the individual user is encouraged. Reports should be submitted as follows:

a. (F) Air Force - AFTO Form 22 directly to: Commander, Sacramento Air Logistics Center, ATTN: MMEDT, McClellan Air Force Base, CA 95652, in accordance with TO-00-5-1.

b. (A) Army - DA Form 2028 direct to: Commander, US Army Troop Support Command, ATTN: AMSTR-MCTS, 4300 Goodfellow Boulevard, St. Louis, MO 63120-1798.

c. (N) Navy - by letter directly to: Commanding Officer, CB Center, ATTN: Code 153, Port Huenene, CA 93043.

d. (MC) Marine Corps - by NAVMC Form 10772 directly to: Commandant, Headquarters, US Marine Corps, ATTN: Code LMA-1, WASHINGTON DC 20380.

1-5. LEVELS OF MAINTENANCE ACCOMPLISHMENT. The authorized maintenance repair functions will be accomplished as follows:

a. (F) Air Force users shall accomplish maintenance at the user level consistent with their capability in accordance with policies established in AFM-66-1.

b. (A, MC) Army and Marine Corps users shall refer to the maintenance Allocation Chart (MAC), in conjunction with the applicable SL-4, for tasks and levels of maintenance to be performed.

AIR FORCE TO 35C2-3-442-11  
ARMY TM5-6115-600-12  
NAVY NAVFAC P-8-628-12  
MARINE CORPS TM-07464B-12

c. (N) Navy users shall determine their maintenance levels in accordance with their service directives.

1-6. DESTRUCTION OF ARMY MATERIEL TO PREVENT ENEMY USE. (A, MC) Demolition of materiel to prevent enemy use will be in accordance with the requirements of TM-750-244-3, Procedures For Destruction of Equipment to Prevent Enemy Use.

1-7. ADMINISTRATIVE STORAGE. (F, A, MC). For procedures to accomplish storage, Air Force personnel should refer to TO 35-1-4, Processing and Inspection of Aerospace Ground Equipment for Storage and Shipment. Army personnel should refer to TM 740-90-1, Administrative Storage. Marine Corps personnel should refer to MCO P4450.7.

1-8. PREPARATION FOR SHIPMENT AND STORAGE.

a. Document References. Shipment and storage preparations for the various services are contained in the following documents:

(1) (F) Air Force - Refer to TO 35-1-4 for end item generator sets and TO 38-1-5 for installed engine.

(2) (A) Army - Refer to TB 740-97-2 and TM 740-90-1.

(3) (N, MC) Navy and Marine Corps-Refer to individual service directives for requirements.

b. Preparation for Domestic Shipment. These procedures shall be accomplished without the use of preserved or stored components.

(1) Clean generator set as specified in paragraph 3-18.

(2) Inspect the generator set for damaged components, rust, water accumulation, and pilferage.

(3) Check that all basic issue items are on hand and properly stowed. Refer to Appendix B.

### WARNING

Corrosion preventive compound (MIL-C-16173) is flammable and slightly toxic. Avoid skin and eye contact or breathing of vapor. Skin, eye and respiratory protection is required.

(4) Repair all damaged surfaces. Coat unprotected metal surfaces with a preservative conforming to Military Specification MIL-C-16173, Grade 3.

(5) Lubricate generator set and change oil in accordance with lubrication order of figure 3-1.

(6) Service radiator with coolant for the lowest expected ambient temperature (refer to paragraph 3-14b). Operate engine until normal operating temperature is reached.

(7) Drain 1 gallon (3.785 liters) of fuel from both fuel and day tanks (refer to paragraphs 3-12c and e) and substitute with 1 gallon (3.785 liters) of preservative oil conforming to Military Specification MIL-L-21260, Grade 2.

(8) Start and operate generator set until operating temperature is reached (refer to paragraph 2-4). After 5 minutes shut down engine (refer to figure 2-10).

(9) Disconnect and remove batteries (refer to paragraph 4-29). Secure battery cables with tape (Federal Specification PP-T-60, Class 1).

(10) Seal all openings with tape (Federal Specification PP-T-60, Class 1).

(11) Mark the generator set in accordance with Military Standard MIL-STD-129.

c. Loading Equipment for Shipment.

### NOTE

Generator sets are not to be transported by air or forwarded to a repair facility with compressed ether cylinder attached.

After loading generator set on transporter, block and tie it so that it will not move during transit.

d. Preparation for Limited Storage. Limit storage is defined

as storage which does not exceed 6 months. Prepare generator set for limited storage as follows:

(1) Perform the procedures specified in paragraph 1-8a and b, "Preparation For Shipment and Storage", except as follows: Disconnect and remove battery (refer to paragraph 4-29). Secure battery cables with tape (Federal Specification PP-T-60, Class 1). Charge batteries fully before storing.

(2) Every effort should be made to provide a protected storage area for the generator set. If this is impossible, select a firm, level, well-drained storage location which is

protected from prevailing winds. Position the generator set on heavy planking.

e. Limited Storage Inspection. Generator sets in limited storage shall be inspected and operated every 90 days.

(1) Perform semi-annual preventive maintenance checks and services (refer to table 4-2).

(2) Start and operate engine until it reaches operating temperature (refer to paragraph 2-4). Shut down the engine (refer to figure 2-10).

(3) Return the generator set to limited storage condition (refer to paragraph 1-8d).

## Section II. DESCRIPTION AND DATA

### 1-9. DESCRIPTION.

a. The generator set, military model MEPO07B (figures 1-1 and 1-2) is a self-contained source of ac electrical power. A 100 KW synchronous, brushless generator is directly driven by a turbocharged, six-cylinder diesel engine. Both the engine and generator are mounted on a welded I-beam skid base and contained within a steel-paneled housing enclosure. The generator set is provided with the controls, instruments, and accessories necessary for its operation, monitoring, and control.

b. Access to the generator set's electrical output is provided by a reconnection panel. This panel also makes it possible to change the electrical output to either 120/208 or 240/416 volts.

c. Two types of winterization kits are available as auxiliary equipment: one fuel burning; the other, electric. Both of these kits ensure generator set starting in extreme cold weather conditions.

1-10. TABULATED DATA. The information necessary to operate and maintain the generator set at the operator and organizational level is contained in table 1-1, Tabulated Data. The location and content of the various identification plates are also provided as are the schematic, cabling, and fuel system diagrams.

a. Tabulated Data. Table 1-1 lists such information as manufacturer, model (type), weight (both dry and wet), height, width, and length of the generator set. Similar information on the generator set's auxiliary equipment (winterization kits) is also provided. Additional reference data on many of the major components is also included.

b. Identification Plates. The generator set has fifteen major identification plates located as shown in figure 1-3. These plates provide specific information on the equipment specified.

c. Diagrams and Tables.

(1) Troubleshooting Diagrams. The AC system troubleshooting diagram provides servicing information on the generator

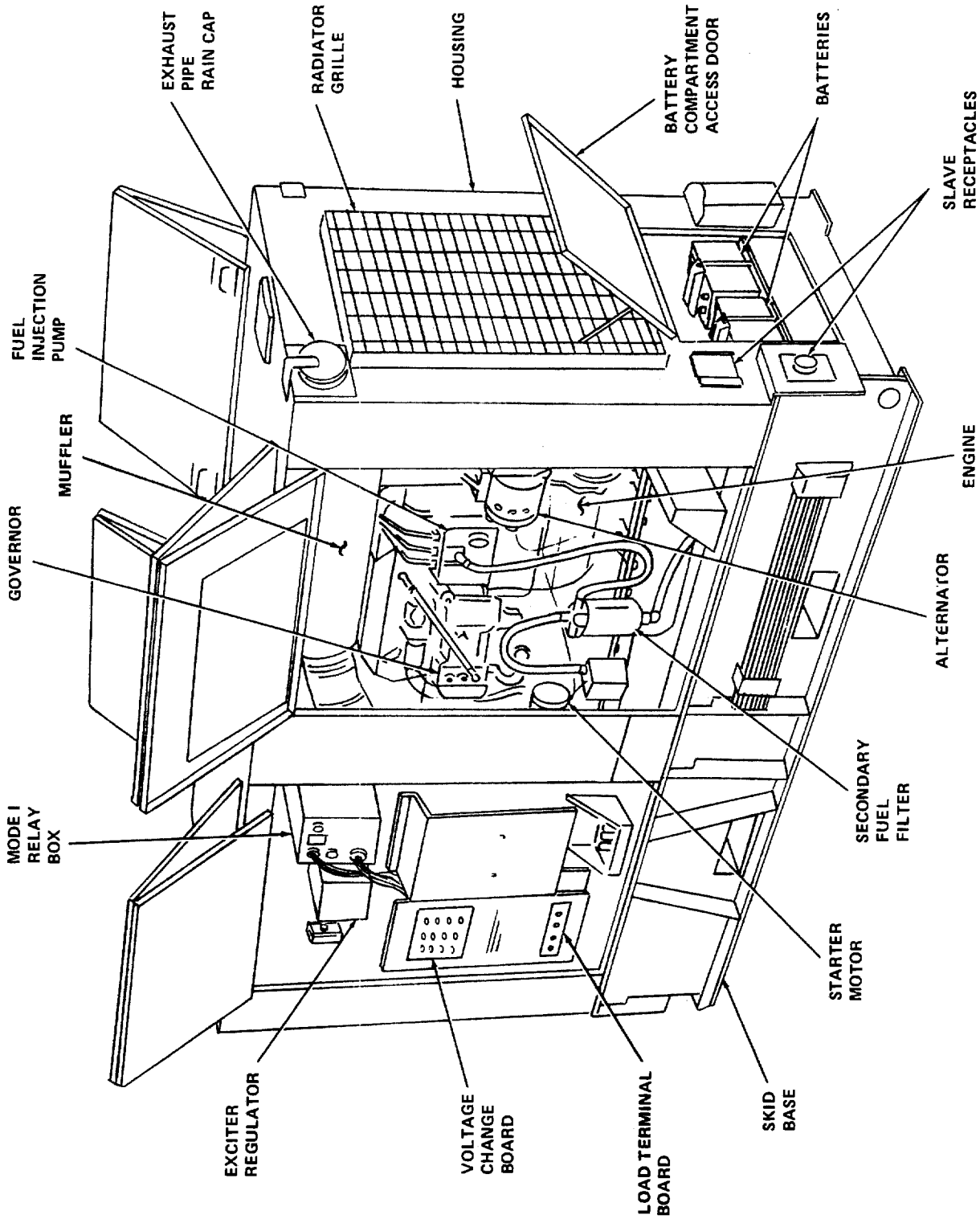

Figure 1-1. Generator Set, Right Front, Three Quarter View

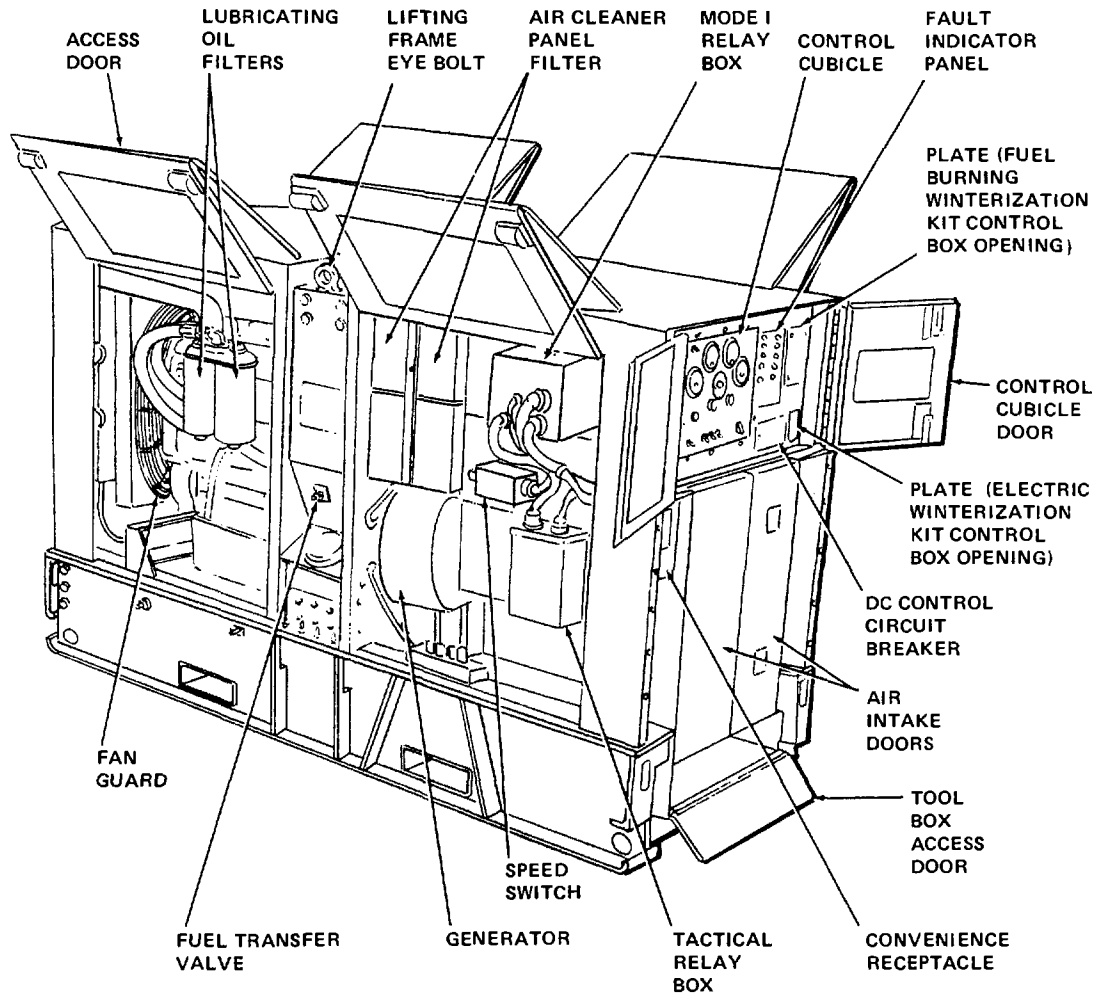

Figure 1-2. Generator Set, Left Rear, Three Quarter View

and associated circuits and is shown in F0-1. The DC system troubleshooting diagram provides servicing information on the control and operating circuits of the engine and is shown in F0-2.

(2) Generator Set

Interconnection Diagram. This diagram shows how the various components of the generator set are interconnected and is illustrated in F0-3.

(3) Fuel System Diagram.

This diagram shows how the fuel is routed from the supply tank to the fuel injectors and back again and is illustrated in figure 1-4.

(4) Electrical Schematics.

Schematic diagrams of the AC system, DC system, exciter-regulator A11, and fault indicator panel A9 are shown in F0-4, F0-5, F0-6, and figure 1-5, respectively.

(5) Fuel Burning Winterization Kit Wiring and Schematic Diagrams. These diagrams show the electrical connections to and from the fuel burning winterization kit. See figures 1-6 and 1-7.

(6) Electric Winterization Kit Wiring and Schematic Diagrams. These diagrams show the electrical connections to and from the electric winterization kit. See figures 1-8 and 1-9.

(7) Torque Data. Table 1-2 lists components that require special torquing information.

(8) Maintenance and Operating Supplies. Refer to table 3-1 for a complete list of Maintenance and Operating Supplies required for initial operation.

Table 1-1. Tabulated Data

1. GENERATOR SET

Generator Set Manufacturer	Fermont Division, Dynamics Corp. of America
DOD Drawing Number	76-007
Model	MEP007B
Mode	50/60 Hz
Class	Utility
Operating Temperature Range	
Without Winterization Kit	-25 to 125 <sup>0</sup> F (-32 to 52 <sup>0</sup> C)
With Winterization Kit	-65 to 125 <sup>0</sup> F (-54 to 52 <sup>0</sup> C)
Voltage Output	120/208 V ac and 240/416 V ac, 3-phase, 4 wire
Voltage Regulation	1 percent (max) from no load to full load
Voltage Stability (Rated Voltage)	
Short Term (30 Seconds)	1 percent bandwidth from no load to rated full load
Long Term (4 Hours)	2 percent bandwidth from no load to rated full load
Voltage Transient Performance	Recovery to 95 percent (min) within 0.7 seconds from no load to rated full load
Voltage Adjustment	60 Hz 120/208 V ac: 197 to 240 V 240/416 V ac: 395 to 480 V 50 Hz 120/208 V ac: 190 to 213 V 240/416 V ac: 380 to 426 V
Frequency Regulation	Isochronous +/-1/4 of 1 percent
Frequency Stability:	
Short Term (30 Seconds)	within bandwidth equal to 1/2 of 1 percent of rated frequency
Long Term (4 hours)	within bandwidth equal to 1 per- cent of rated frequency
Frequency Drift (8 Hours)	1/2 of 1 percent
Transient Performance (application of rejection of load)	
Stable Operation	within 2 seconds
Overshoot or Undershoot	4 percent of rated frequency
Power Factor	0.8
Capacities:	
Fuel System	91 gal. (344.4 liters)
Cooling System	42.3 qts (160.1 liters)
Lube Oil System	30 qts (28.4 liters)

Table 1-1. Tabulated Data (Cont)

Dimensions and Weights:

Overall Length	106 in. (26.9 m)
Overall Width	40 in. (10.2 m)
Overall Height	65 in. (16.5 m)
Net Weight (empty)	6680 lbs (3030 kg)
Net Weight (filled)	7500 lbs (3375 kg)
Shipping Weight	8400 lbs (3780 kg)

2. DC ELECTRICAL AND CONTROL SYSTEM

Battery Cables

Positive Lead

DOD Drawing Number	71-4563-03
Wire	1/0
Length	30.0 in (770 mm)
Color	Red
Terminal Lugs	MS20659-118
Battery Adapter	MS75004-1

Positive-Negative Lead

DOD Drawing Number	71-4562-01
Wire	1/0
Length	7.5 in. (190.5 mm)
Color	Red or Black
Terminal Lugs	MS20659-118
Battery Adapters	MS75004-1 and MS75004-2

Negative Lead

DOD Drawing Number	71-4564-03
Wire	1/0
Length	40.0 in. (10.2 m)
Color	Black
Terminal Lugs	MS20659-118
Battery Adapter	MS75004-2

Batteries

Specifications

MS35000-3	
Weight	
(Filled)	71 lbs (32 kg)
(Dry)	52 lbs (23 kg)
Length	11.25 inches (285 mm)
Width	10.5 inches (266 mm)
Height	8.9 inches (200 mm)
Class	FE
Nominal Voltage	12 V
Final Voltage (at 20 hour rate)	10.5 V
Rated Capacity (at 20 hour rate)	100 amp-hours
Discharge (at 20 hour rate)	5 amps
Charging Rate	5 amps

Table 1-1. Tabulated Data (Cont)

Slave Receptacle (SR-1)	
DOD Drawing Number	71-4561
Receptacle	MS75058-1
Alternator (G2)	
DOD Drawing Number	69-780-2
Manufacturer	Motorola, Inc.
Model	70D44672802
Weight	9 lbs (4 kg)
Length	8.34 inches (212 mm)
Height	7.40 inches (188 mm)
Diameter	5.5 inches (140 mm)
Operating Temperature Range	-65 to 175°F (-53 to 80°C)
Output Amperage (any speed from 1900 to 4000 rpm)	0 to 15 amps
Output Voltage, Maximum (with batteries disconnected)	32 V dc
Transient Voltage, Maximum	50 V dc
RMS Ripple Voltage Percentage, Maximum (with batteries disconnected, over loads of 0 to 20 amps)	5 percent
Speed Switch and Magnetic Pick-up	
Speed Switch (S9-1 and S9-3)	
DOD Drawing Number	76-4124-02
Manufacturer	Synchro-Start Products, Inc.
Model	ESSB-3MC
Contact Rating	10 amps resistive at 24 V dc
Power Input	8 to 40 V dc
Hz Signal Input, Minimum (peak to peak)	1.4 V
Application	50/60 Hz
Magnetic Pick-up	
DOD Drawing Number	76-4189
Manufacturer	Synchro-Start Products, Inc.
Model	SE-1050
Operating Temperature Range	-65 to 200°F (-53 to 93°C)
Low Oil Pressure Switch (OP)	
DOD Drawing Number	70-4043
Manufacturer	The Nason Co.
Model	SP1Z15FA
Contacts	1 NC, 1 NO
Operating Pressure	15 ±3 psi
Contact Operation	Simultaneously
Rating	28 V dc, 15 amp resistive, 10 amp inductive
Maximum Operating Oil Pressure	100 psi
Maximum Operating Oil Temperature	230°F (109°C)
Minimum Non-Operating Oil Temperature	-65°F (-53°C)



Table 1-1. Tabulated Data (Cont)

High Coolant Temperature Switch (WT)	
DOD Drawing Number	69-697-4
Manufacturers and Model Numbers:	The Nason Co. TC-150-222-4ANSL Amot Controls 4169B-222
Rating	10 amp, 28 V dc
Connector	MS3102R-14S2P
Contact Transfer Point	222 $\pm$ 3 <sup>0</sup> F (105 $\pm$ 2 <sup>0</sup> C)
Ambient Temperature Range	-65 to 175 <sup>0</sup> F (-53 to 19 <sup>0</sup> C)
DC Circuit Breaker	
DOD Drawing Number	70-4175
Circuit Breaker (CB1)	
Specification	MS25244-7-1/2
Rating	7.5 amps
Voltage Drop (max)	0.25 V
Operating Force:	
Pullout	8 lbs (3.6 kg)
Reset	12 lbs (5.4 kg)
Starter Assembly	
DOD Drawing Number	70-4046
Manufacturer	Prestolite
Model	MFY-6501EUT
Type	24 V dc, Heavy Duty, Solenoid Actuated
Classification	Type II (Ring Gear Engagement) Grade A (Waterproof) Class 1 (Positive Drive)
Fuel Shutdown Solenoid (L1)	
Manufacturer	Caterpillar
Part No.	4N5679
Model	24 V dc
Type	Energized-to-Run
Pull-In Current	10 amperes
Hold-In Current	2 amperes
Plunger Shaft Travel	0.9 inches (22 mm)

Table 1-1. Tabulated Data (Cont)

3. SET CONTROLS AND INSTRUMENTATION

Fault Locating Indicator (A9)	
DOD Drawing Number	69-530
Relay (A7)	
Specification	MIL-R-5757/23
Type	M5757/23-003
Fault Indicator Assembly	
DOD Drawing Number	69-540
Resistor (R1 to R10)	
Specification	MIL-R-39008/2
Identifying Number	RCR20G222JM
Type	Fixed, Comp, 2.2 K, $\pm 10$ percent, 1/2 W
Resistor (R11 to R20)	
Specification	MIL-R-39008/2
Identifying Number	RCR20G102JM
Type	Fixed, Comp, 1.0 K, $\pm 10$ per- cent, 1/2 W
Rectifier, Silicon Control (SCR1 to SCR10)	
DOD Drawing Number	69-542
Manufacturers and Model Numbers:	General Electric Co. 2N1596 Motorola, Inc. 2N1596 Texas Instrument Inc. 2N1596
Minimum Forward Breakover Voltage	100 V (with 1000 ohms or less connected from gate to cathode)
Repetitive Peak Reverse Voltage	100 V
Repetitive Peak Forward Blocking Voltage	100 V
RMS Forward Current	1.6 amps
Peak Forward Blocking Current	1 ma max
Peak One-Cycle Surge Current	15 amps
Peak Gate Power	0.1 W
Average Gate Power	0.01 W
Peak Gate Current	0.1 amp
Gate Trigger Current (Continuous)	10 ma dc
Peak Gate Voltage (Forward and Reverse)	6 V
Gate Trigger Voltage (Continuous)	0.2 V dc min
Storage Temperature	-85 to 302°F (-65 to 150°C)
Operating Temperature	-85 to 257°F (-65 to 125°C)

Table 1-1. Tabulated Data (Cont)

Rectifier, Silicon (CR1 to CR10)	
Specification	MIL-S-19500/427
Identifying Number	JAN 1N5614
Type	200 prv
Capacitor (C1 to C10)	
Specification	MIL-C-39002/1
Identifying Number	M39022-01-1661
Type	Fixed, Plastic Film Dielectric, 0.10 uf, ±10 percent, 200 V dc
Fuse (F1)	
Specification	MIL-F-15160/2
Type	F02A250V1AS
Control Box Assembly (A3)	
DOD Drawing Number	69-590-6
Voltage Meter (M9)	
DOD Drawing Number	69-599
Manufacturers and Model Numbers:	Weston Instrument Inc. 254013 A & M Instrument Inc. AEL5N13001 Phaotron Instrument and Electronics Co. 633-16752
Scale	0 to 500 V
Markings	Double-width red markings at 120, 208, 240, and 416 V
Initial Error (max)	2-1/2 percent of full scale
Wattmeter (M7)	
DOD Drawing Number	70-4012
Manufacturers and Model Numbers:	Weston Instrument Inc. 260935 Phaotron Instrument and Electronics Co. 631-16755 A & M Instrument Inc. 300-15
Rating (full scale)	1.2 ma
Resistance Value	10 to 100 ohms
Operating Temperature Range	-65 to 155°F (-53 to 68°C)
Scale Markings:	
Red Mark	83 percent power
Blue Mark	100 percent power

Table 1-1. Tabulated Data (Cont)

Watt Converter (A1)	
DOD Drawing Number	69-589-1
Manufacturer	Electromagnetic Industries Inc.
Model	21820A
Application	50/60 Hz
Input Voltage	100 to 130 V ac
Input Watts	0 to 288
Output Current	0 to 1.2 amp dc
Operating Temperature Range	-65 to 155°F (-53 to 68°C)

Ammeter (M8)	
DOD Drawing Number	69-597
Manufacturers and Model Numbers:	Weston Instrument Inc. 267842
	Phaotron Instrument and Electronics Co. 637-16750
	A & M Instrument Inc. 300-10
Application	50/60 Hz
Full Scale: 50 Hz	160 percent rated current
60 Hz	133 percent rated current
Scale 100 Percent Mark: 50 Hz	0.625 amp
60 Hz	0.75 amp
Scale Markings: 50 Hz	100 percent
Double width blue line	
60 Hz	100 percent
Double width red line	

Rheostat (R1 and R2)	
DOD Drawing Number	69-548
Manufacturer	Ohmite Manufacturing Co.
Model	RP101FD251KK
Resistance Value	250 ohms ±10 percent
Maximum Current	0.32 amp
Power Rating	25 W at 77°F (25°C)

Frequency Meter and Transducer (M6 and A2)

NOTE

The frequency meter and transducer are furnished and replaced as matched set only.

Table 1-1. Tabulated Data (Cont)

DOD Drawing Number	69-595															
Manufacturers and Model Numbers:	Weston Instrument Inc. 268420 Electromagnetic Industries Inc. 22020 A & M Instrument Co. 300-12															
Operating Voltage Range	105 to 139 V															
Operating Temperature Range	-65 to 125°F (-53 to 51°C)															
Input	120 V ac, single-phase, 50/60 Hz															
Engine Primer Switch (S1)																
Specification	MS35058-30															
Type	Toggle, one pole, sealed toggle momentary ON-NONE-OFF															
Lampload Circuit	5 amps at 28 V dc; 2 amps at 115 V ac, 400 Hz															
Resistive Circuit	20 amps at 28 V dc; 10 amps at 115 V ac, 400 Hz or 60 Hz															
Inductive Circuit	10 amps at 28 V dc; 7 amps at 115 V ac, 400 Hz or 60 Hz															
Start-Stop-Run Switch (S2)																
DOD Drawing Number	69-572															
Manufacturer	Cutler-Hammer Inc.															
Model	8506K1359															
Type	Toggle															
Circuits:	Toggle Position															
	<table border="0"> <tr> <td>A</td> <td>B</td> <td>C</td> </tr> <tr> <td>2-3</td> <td>2-3</td> <td>OFF</td> </tr> <tr> <td>5-6</td> <td>OFF</td> <td>OFF</td> </tr> <tr> <td>8-9</td> <td>8-9</td> <td>OFF</td> </tr> <tr> <td>11-12</td> <td>OFF</td> <td>OFF</td> </tr> </table>	A	B	C	2-3	2-3	OFF	5-6	OFF	OFF	8-9	8-9	OFF	11-12	OFF	OFF
A	B	C														
2-3	2-3	OFF														
5-6	OFF	OFF														
8-9	8-9	OFF														
11-12	OFF	OFF														
Circuit Breaker OPEN-CLOSE Switch (S3)																
Specification	MS25201-6															
Type	Toggle, two pole, sealed toggle															
Lampload Circuit	5 amps per pole at 28 V dc, 2 amps per pole at 115 V, 400 Hz or 60 Hz															
Resistive Circuit	18 amps per pole at 28 V dc, 11 amps per pole at 115 V, 400 Hz or 60 Hz															
Inductive Circuit	10 amps per pole at 28 V dc, 8 amps per pole at 115 V, 400 Hz or 60 Hz															

Table 1-1. Tabulated Data (Cont)

Panel Light ON-OFF Switch (S4)	
Specification	MS35058-22
Type	Toggle, one pole, sealed toggle OFF-NONE-ON
Lampload Circuit	7 amps at 28 V dc, 3 amps at 115 V, 400 Hz
Resistive Circuit	25 amps at 28 V dc, 10 amps at 115 V, 400 Hz or 60 Hz
Inductive Circuit	15 amps at 28 V dc, 10 amps at 115 V, 400 Hz or 60 Hz
Voltage Sensing Remote-Local Switch (S5)	
Specification	MS35059-23
Type	Toggle, two pole, sealed toggle ON-NONE-OFF
Lampload Circuit	7 amps at 28 V dc, 4 amps at 115 V, 400 Hz
Resistive Circuit	20 amps at 28 V dc, 20 amps at 115 V, 400 Hz or 60 Hz
Inductive Circuit	15 amps at 28 V dc, 15 amps at 115 V, 400 Hz or 60 Hz
Parallel Operation-Single Unit Operation Switch (S6)	
Battle Short Switch (S7)	
Specification	MS25068-23
Type	Toggle, four pole, sealed toggle ON-NONE-ON
Lampload Circuit	5 amps at 28 V dc, 4 amps at 115 V, 400 Hz
Resistive Circuit	20 amps at 28 V dc, 20 amps at 115 V, 400 Hz
Inductive Circuit	12 amps at 28 V dc, 15 amps at 115 V, 400 Hz
Volt-Amp Transfer Switch (S8)	
DOD Drawing Number	70-4016
Manufacturers and Model Numbers:	Electroswitch Corp. 31904LT S.H. Couch Division, ESB Corp. S462 Cutler-Hammer Inc. 8918K1115
Current Circuits (max)	500 V at 40 Hz to 450 Hz
Voltage Circuits (max)	0.5 amp switching at 500 V, 40 Hz to 450 Hz
Operating Temperature Range	-65 to 155°F (-53 to 68°C)

Table 1-1. Tabulated Data (Cont)

Oil Pressure Indicator (M1)	
DOD Drawing Number	69-576-2
Manufacturer	Stewart-Warner Corp.
Model	505-BD
Rating	24 V dc
Range	0 to 120 psi
Coolant Temperature Indicator (M2)	
DOD Drawing Number	69-577
Manufacturer	Stewart-Warner Corp.
Model	505-BE
Rating	24 V dc
Range	120 to 240°F (48 to 114°C)
Liquid Quantity (Fuel) Indicator (M3)	
DOD Drawing Number	69-575
Manufacturer	Stewart-Warner Corp.
Model	505-BC
Rating	24 V dc
Range	Empty to full
Ammeter, DC (M4)	
DOD Drawing Number	69-574
Manufacturers and Model Numbers:	Weston Instrument Inc. 253633
	Phaotron Instrument and Electronics Co. 621-16749
	A & M Instrument Inc. 300-17
	Ideal Precision Meter Co. 26-5773
Range	25 to 0 to 50 mv
Scale	-10/0/20 amps
Internal Impedance	250 ohms (min)
Time Totalizing Meter (M5)	
DOD Drawing Number	73-0507
Manufacturers and Model Numbers:	Hobbs Division, Stewart-Warner Corp. M-5600
	Datcon Instrument Co. 771 P/N 56181-4
Specification	MIL-M-3971/1, Type 1
Control Panel Relay Assembly (A4)	
DOD Drawing Number	69-765

Table 1-1. Tabulated Data (Cont)

Resistor (R10)	
Specification	MIL-R-39007/7
Identifying Number	RWR78S150FM
Type	Fixed, wound-wire
Rectifier, Bridge, Silicone (CR1)	
DOD Drawing Number	69-739
Manufacturer	Edal Industries Inc.
Model	B-598-40
Average Forward Current (DC)	2 amps
Peak One-Cycle Surge Current	50 amps
Peak Surge Current, 1 Sec at 60 CPS	8 amps
Working Peak Reverse Voltage	400 V
Blocking Voltage, DC	400 V (max)
Working Voltage	280 V rms
Reverse Current, DC	10 ua (max)
Insulation Strength (Circuit to Case)	2000 V dc (min)
Junction Operating Temperature	-58 to 302 <sup>0</sup> F (-50 to 150 <sup>0</sup> C)
Relay (K1 and K6)	
Specification	MIL-R-5757
Identifying Number	MIL-R-5757/23-003
Capacitor (C2)	
Specification	MIL-C-39006/2
Identifying Number	M39006/02-1240
Type	Non-polarized
Fuel Level (Liquid Quantity) Transmitter (MT3)	
Identifying Number	MS500040-2
Type	Class 1, float-type
Coolant Temperature Transmitter (MT2)	
DOD Drawing Number	69-781
Manufacturer	Stewart-Warner Corp.
Model	506-AE
Voltage	24 V dc
Oil Pressure Transmitter (MT1)	
DOD Drawing Number	69-779-02
Manufacturer	Stewart-Warner Corp.
Model	506-AD
Voltage	24 V dc, 120 psi



Table 1-1. Tabulated Data (Cont)

4. AC ELECTRICAL CONTROL SYSTEM

Tactical Relay Assembly (A29)	
DOD Drawing Number	70-4206
Overvoltage Relay (K2)	
DOD Drawing Number	70-1138
Manufacturer	Electromagnetic Industries Inc.
Model	11486
Nominal Voltage	120 V, 50 to 450 Hz
Operating Voltages	156 V at 50 to 100 Hz 151 V at 350 to 450 Hz
Contact Rating	10 amps resistive at 28.5 V dc
Contact Arrangement	DPDT, 2 NC, 2 NO
Contact Trip Point	165 V
Time Delay	0.18 to 0.8 sec
Operating Temperature Range	-85 to 181°F (-65 to 85°C)
Temperature/Trip Effect:	
-85°F (-65°C)	±1 V
181°F (85°C)	±1 V
Short Circuit Relay (K13)	
DOD Drawing Number	70-1137
Manufacturers and Model Numbers:	Electromagnetic Industries Inc. 23380 Fermont Division, Dynamics Corp. of America 6105-0001
Trip Voltage	24 V ±0.3 V at 60 Hz
Frequency Range	50 to 400 Hz
Frequency/Trip Effect	±0.6 V
Operating Temperature Range	-65 to 170°F (-53 to 76°C)
Temperature/Trip Effect	±0.6 V
Contact Rating	10 amps resistive at 28 V dc
Type	SPST, 1 NO, 1 NC
Reverse Power Relay (K15)	
DOD Drawing Number	70-1136
Manufacturers and Model Numbers:	Electromagnetic Industries Inc. 21690-1 International Signal and Controls 8170400
Input Voltage	0-10 V dc (signal) with 20 V ac superimposed
Trip Voltage	2 ±0.1 V dc (20 percent of reverse power)
External Power Required	24 V dc
Frequency Range of Superimposed (AC) Voltage	50 to 400 Hz
Frequency/Trip Effect	±0.5 V
Contact Rating	10 amps resistive at 28 V dc
Type	SPST, 1 NO, 1 NC

Table 1-1. Tabulated Data (Cont)

Overload Relay Assembly (K14)	
DOD Drawing Number	70-1135
Manufacturers and Model Numbers:	Fermont Division, Dynamics Corp. of America 6105-0001 Precision Electronics Inc. 5532
DC Input	28 V nominal at 0.1 amp max
AC Input	3-phase, 3 wire, 0.75 amps per phase
Contact Rating	125 V ac at 10 amps
Type	SPST, 1 NO, 1 NC
Trip Point (60 Hz)	130 percent of 0.75 amps (0.975 to 0.985 amps)
Frequency Range	50 to 400 Hz
Temperature Range	-65 to 170°F (-53 to 76°C)
Resistor Assembly, Current Transformer, Load (A7)	
DOD Drawing Number	70-4209
Resistor (R23, R24, and R25) Specification	MIL-R-39009/1
Identifying Number	RER75F7R50M
Type	Fixed, wound-wire, 7.5 ohms ±1 per- cent, 10 W
Relay Assembly Group (A27)	
DOD Drawing Number	79-4512
Electronic Components Assembly	
DOD Drawing Number	70-4238
Relay (K3) Identifying Number	MS24166-D1
Shunt, Instrument (R13) Identifying Number	MS91586-10
Transformer, Current Sensing (T1)	
DOD Drawing Number	70-4064
Manufacturer	Consolidated Diesel Electric Co.
Model	00000-4836
Test Frequency	60 Hz
Rated Voltage:	
Terminals 1 and 2	5.0 V, ±5 percent at rated load
Terminals 3 and 4	4.8 V, ±5 percent at rated load
Rated Current	0.4 amp
Resistance:	
Terminals 1 and 2	0.85 ohms at 80°F (26°C)
Terminals 3 and 4	0.90 ohms at 80°F (26°C)
Turn Ratio	1:1
Temperature Range	-65 to 155°F (-53 to 68°C)

Table 1-1. Tabulated Data (Cont)

Resistor (R1)	
Specification	MIL-R-26/13
Identifying Number	RW29V100
Type	Fixed, wound-wire
DC Relay Assembly	
DOD Drawing Number	69-768
Resistor (R7 and R8)	
Specification	MIL-39007/7
Identifying Number	RWR78S2671FR
Type	Fixed, wound-wire
Resistor (R6 and R9)	
Specification	MIL-R-26/4
Identifying Number	RW56V512
Type	Fixed, wound-wire
Resistor (R3)	
Specification	MIL-R-39007/7
Identifying Number	RWR78S1501FR
Type	Fixed, wound-wire
Rectifier, Junction, Silicon (CR3)	
DOD Drawing Number	69-741
Manufacturers and Model Numbers:	General Electric, Semiconductor Division IN1695 Transitron Electronic Corp. IN1695 Zeus Industrial Products Inc. IN1695
Maximum Allowable PRV	400 V
Maximum Allowable RMS Voltage	280 V
Maximum Allowable Continuous Reverse DC Voltage	400 V
Maximum Allowable DC Output (at 212°F/100°C, ambient)	250 ma
Maximum Allowable DC Output (at 122°F/50°C, ambient)	600 ma
Maximum Allowable 1 Cycle Surge Current	20 amps
Maximum I <sup>2</sup> T (T < 0.008 Sec)	0.93 amp/2sec
Maximum Full Load Forward Voltage Drop (Full Cycle Average at 212°F/100°C)	0.60 V
Maximum Leakage Current at Rated PRV (Full Cycle Average at 212°F/100°C)	0.5 ma
Peak Recurrent Forward Current	2 amps
Maximum Operating Temperature	239°F (115°C)

Table 1-1. Tabulated Data (Cont)

Rectifier, Bridge, Silicon (CR4)	
DOD Drawing Number	69-739
Manufacturer	Edal Industries Inc.
Model	B-598-40
Average DC Forward Current	2 amps
Peak Surge Current (1 sec to 60 CPS)	8 amps
Junction Operating Temperature	-58 to 238 <sup>0</sup> F (-50 to 150 <sup>0</sup> C)
Working Peak Reverse Voltage	400 V
DC Blocking Voltage	400 V max
Working Voltage	280 V rms
Reverse DC Current	10 $\mu$ a max
Rectifier, Junction, Silicon (CR6)	
DOD Drawing Number	69-740
Manufacturer	Motorola, Inc.
Model	MR1034A
Peak Repetitive Reverse Voltage	400 W
Non-Repetitive Peak Reverse Voltage (1/2 wave, 1 phase, 60 cycle peak)	500 W
RMS Reverse Voltage	280 V
Average Rectified Forward Current (1 phase, 60 CPS)	3 amps at 167 <sup>0</sup> F (75 <sup>0</sup> C)
Peak Repetitive Forward Current (Superimposed on riced current at rated vltage)	300 amps (for 1/2 cycle)
Maximum $I^2T$ (1 m sec < T < 8.3 m sec)	185 (rms) <sup>2</sup> sec
Maximum Junction Operating Temperature	-85 to 347 <sup>0</sup> F (-65 to 175 <sup>0</sup> C)
Maximum Storage Temperature	-85 to 347 <sup>0</sup> F (-65 to 175 <sup>0</sup> C)
Maximum Steady State DC Thermal Resistance	86 <sup>0</sup> F (30 <sup>0</sup> C)/W
Relay (K5, K7, and K8)	
Specification	MIL-R-5757/23
Identifying Number	M5757/23-003
Circuit Breaker Assembly (CB2)	
DOD Drawing Number	76-4191
Dimensions	12 x 6 x 3-3/4 inches (304.8 x 152.4 x 95 mm)
Relay Box Assembly, Circuit Breaker	
DOD Drawing Number	76-4172
Relay (K27)	
Specification	MIL-R-5767
Identifying Number	M5757/23-003
Relay (K26)	
Specification	MS-27401
Identifying Number	MS-27401-2

Table 1-1. Tabulated Data (Cont)

Motor Control, Circuit Breaker	
DOD Drawing Number	76-4193
Manufacturer	Electromagnetic Industries Inc.
Model	63030-21150
 Circuit Breaker	
DOD Drawing Number	76-4182-01
Main Contacts	3 pole, 400 amps
Minimum Current Rating:	
at 208 V ac	350 amps (continuous)
at 416 V ac	175 amps (continuous)
Interrupting Capability:	
at 208 V ac	42,000 amps rms
at 416 V ac	30,000 amps rms
Maximum Breaker Load	1600 amps for 4 seconds
Auxiliary Contacts:	
Number	3
Type	A
Rating	10 amps
Panel Lamp Contact:	
Type	A
Rating	5 amps
Operating Temperature Range	-65 to 135°F (-53 to 56°C)
 Convenience Receptacle Box Assembly	
DOD Drawing Number	70-4101
 Circuit Breaker (CB3)	
Identifying Number	MS25244-15
Rating	15 amps
Voltage Drop (max)	0.25 V
Operating Force (max)	
Pullout	8 lbs
Reset	12 lbs
Interrupting Current	3500 amps
 Transformer Assembly	
DOD Drawing Number	71-4472
 Transformer, Cross Current (CT7)	
DOD Drawing Number	70-4085
Manufacturer	Electromagnetic Industries Inc.
Model	No. 6 400/1 ratio
Primary Current	600 amps
Primary Voltage	600 V
Secondary Current	1.5 amps
Turns Ratio	400:1 (with 1 turn primary)
Frequency	50/60 Hz and 400 Hz
Burden	25 V amps min
Storage Temperature Range	-65 to 155°F (-53 to 68°C)

Table 1-1. Tabulated Data (Cont)

Transformer, Exciter (CT4)	
DOD Drawing Number	70-4067
Manufacturer	Consolidated Diesel Electric Co.
Model	00000-4921
Rated Voltage	60 V
Rated Current	2.7 amps
Test Frequency	60 Hz
Excitation Current (with 60 V applied to terminals 1 and 2)	0.30 amps max
Storage Temperature Range	-65 to 155°F (-53 to 68°C)
Transformer, Instrument (CT1, CT2, and CT3)	
DOD Drawing Number	70-4084
Manufacturer	Electromagnetic Industries Inc.
Model	No. 51
Primary Current	464 amps
Primary Voltage	600 V
Turns Ratio	464:1 (with 1 turn primary)
Frequency	50 to 400 Hz
Burden	12.5 V amps min (at 1 amp secondary current)
Normal Burden	7.5 ohms resistor plus 3 ohms
Storage Temperature Range	-65 to 155°F (-53 to 68°C)
Transformer, Exciter (CT5 and CT6)	
DOD Drawing Number	70-4086
Manufacturer	Consolidated Diesel Electric Co.
Model	00000-4922
Voltage	60 V
Rated Current	8 amps
Resistance	0.22 ohms
Test Frequency	60 Hz
Excitation Current (with 60 V rms applied to terminals 1 and 2)	1.5 amps max
Storage Temperature Range	-65 to 155°F (-53 to 68°C)
5. Fuel System	
Fuel Pump (Electric) (B2 and B3)	
DOD Drawing Number	72-5313
Manufacturer	Facet Enterprises Inc.
Model	480517
Rating	24 V dc
Capacity	25 gph
Output	7 psi +1/4, -1/2
Fuel Filter and Strainers	
DOD Drawing Number	70-507
Manufacturer	Fram Corp.
Model	F2000MIL P/N 240903

Table 1-1. Tabulated Data (Cont)

Fuel Solenoid Valve (Day Tank) (L2)	
DOD Drawing Number	69-787-2
Manufacturer	Skinner Precision Industries Inc.
Model	V5L8720
Nominal Input	24 V
Opening Input Pressure	25 psi
Day Tank	
DOD Drawing Number	70-4246
Fuel Level Switch (FL1 and FL2)	
DOD Drawing Number	70-1594
Manufacturers and Model Numbers:	The Gems Co. Inc. LS40820
Rating	Kaiser Aerospace and Electronics 145-0055
Operating Pressure Range	3.0 amps at 6 to 32 V dc
Operating Temperature Range	0 to 150 psi
Operating Medium	-65 to 200 <sup>o</sup> F (-53 to 93 <sup>o</sup> C)
	Diesel Fuel (DF-1, DF-2, DF-A): specification VV-F-800; maximum sulfur content 0.65 percent
	JP-4: specification MIL-T-5624
Ether Solenoid Valve (L3)	
DOD Drawing Number	70-513
Diode Assembly (A30)	
DOD Drawing Number	71-4700
Diode (CR27 and CR28)	
Specification	MIL-S-19500/286
Identifying Number	JAN1N4245
Fuel Tank Assembly	
DOD Drawing Number	70-4170
Capacity	90 gal. (344 liters)
6. Cooling System	
Radiator Shutter Assembly	
DOD Drawing Number	70-4092
Manufacturers	The Cadillac Co. and G & O Mfg. Co.
Model	1G 409
Thermostat Setting	Nominal 170 <sup>o</sup> F (76 <sup>o</sup> C)
	Crack open 158 <sup>o</sup> F (69 <sup>o</sup> C)
	Full open 173 <sup>o</sup> F (78 <sup>o</sup> C)

Table 1-1. Tabulated Data (Cont)

Radiator			
DOD Drawing Number	70-4088		
Manufacturer	G & O Manufacturing Co.		
Model	X-1817		
Coolant Capacity	21.3 qts (20 liters) (MIL-A-11755)		
Top Tank Temperature	210°F (98°C)		
Maximum Ambient Temperature	125°F (51°C) at sea level		
	107°F (41°C) at 5000 ft elevation		
Heat Rejection:	Engine RPM	Water Flow	Heat Rejection
	1500	62 gpm	35 BTU/min
	1800	70 gpm	34 BTU/min
	2000	80 gpm	37 BTU/min

Coolant Thermostat	
Caterpillar Part Number	7N208
Manufacturer	Standard Thompson Corp.
Model	4A308-21
Min Spring Preload	150 lbs (6.8 kg)
Crack Open	175°F (79°C)
Full Open	195°F (90°C)
Min Travel (Crack to Full Open)	0.375 in. (9.52 mm)

7. Power Generation System

Generator Assembly (G1)	
DOD Drawing Number	70-4001
Manufacturer	Lima Electric Motor Company
Type	Synchronous, brushless alternator with integral exciter
Voltage	120/208 V ac reconnectable to 240/416 V ac, 3-phase, 4 wire
Operating Speed:	
50 Hz	1500 rpm
60 Hz	1800 rpm
Kilowatt Rating:	
50 Hz	83 KW
60 Hz	100 KW
Kilovolt Ampere Rating:	
50 Hz	104 KV amps
60 Hz	125 KV amps
Amperage (3-phase):	
120/208 V ac	288 amps
240/416 V ac	144 amps
	60 Hz
120/208 V ac	346 amps
240/416 V ac	173 amps
Dimensions	30 X 24 inches (762 X 609 mm)
Weight	2000 lbs (1814 t)



Table 1-1. Tabulated Data (Cont)

8. Engine

DOD Drawing Number	76-4106
Manufacturer	Caterpillar Tractor Company
Model	3306T
Type	Four stroke cycle, liquid cooled, turbocharged, tropicalized diesel
Horsepower	181 at 1500 rpm 217 at 1800 rpm
Rotation	Counterclockwise (from flywheel end)
Weight	2320 lbs (1044 kg)
Dimensions	59.26 x 32.77 x 39.4 inches (1505 x 832 x 1000 mm)

9. Winterization Kit, Fuel Burning

DOD Drawing Number	76-4115
Model Number	MEP007BWF
Heater Assembly Engine	
DOD Drawing Number	69-775
Manufacturer	Test Institute Corp.
Model	CP3050-24
Fuel	JP 4 or Arctic diesel fuel
Fuel Rate	21 to 23 cc per minute
Fuel Pressure	3 to 15 psi
Relief Valve Setting	30 to 35 psi
Voltage	24 V dc
Radio Interference Suppression	0.15 to 1000 mega-cycles
Coolant Circulation	80 to 100 gph at 10 psi
Output	
Transfer to Coolant	30,000 BTU per hour max
Usable Exhaust Heat	10,000 BTU per hour max
Operating Power Requirements:	
Above +30°F (-1.1°C)	
Start	14.5 amps
Run	5.0 amps
Below +30°F (-1.1°C)	
Start	17.0 amps
Run	7.5 amps
Weight	20 lbs (9 kg)
Overall Dimensions	19.82 x 10.12 x 6.32 in. (50.3 x 25.7 x 16 cm)
Operating Temperature Range	-25 to -65°F (-32 to -53°C)
Control Box, Fuel Heater	
DOD Drawing Number	74-0650

Table 1-1. Tabulated Data (Cont)

Thermostat Switch, Coolant	
DOD Drawing Number	70-4044
Manufacturer	Nason Co.
Model	TC-125B-50M-2AN
Rating	28 V dc, 15 amps resistive, 10 amps inductive
Maximum Coolant Temperature	230 <sup>0</sup> F (109 <sup>0</sup> C)
Minimum Coolant Temperature	-65 <sup>0</sup> F (-53 <sup>0</sup> C)
Contacts	NC
Contact Open Point	125 ±5 <sup>0</sup> F (51 ±2 <sup>0</sup> C)
Contact Close Point	50 ±5 <sup>0</sup> F (10 ±2 <sup>0</sup> C)

10. Winterization Kit, Electric Heater

Electric Winterization Kit

DOD Drawing Number	76-4116
Model	MEP007BWE

Electric Coolant Heater (2500 Watts)

DOD Drawing Number	70-4073
Manufacturer	Kim Hotstart Manufacturing Co.
Model	BC220
Rating	2500 W at 230 V (nominal, 50/60 and 400 Hz)
Operating Voltage	205 to 240 V
Flow Rate	30 to 40 gph max
Type	Gravity flow, and must have head pressure
Operating Life	1500 hours min at -65 <sup>0</sup> F (-53 <sup>0</sup> C) ambient
Coolant	Arctic anti-freeze per MIL-A-11755
Duty Cycle	Continuous
Weight	1.5 lbs (0.68 kg)
Overall Dimensions	3.50 x 18.00 x 4.50 in. (88.9 x 457.2 x 114.3 mm)

Pump Assembly

DOD Drawing Number	71-4777
--------------------	---------

Pump and Motor Assembly

DOD Drawing Number	70-4048
Manufacturer	Welton Tool Company
Model	P400-E (Rev B)
Rating	80 gph min at 2 psi
Voltage	24 V dc
Duty Classification	Continuous
Motor	
Voltage	20 to 32 V dc
Amps	3.3 max at 80 <sup>0</sup> F (26 <sup>0</sup> C)
RPM	7500

Table 1-1. Tabulated Data (Cont)

Pump and Motor Assembly (Cont)

Coolant	MIL-A-11755
Relief Valve	Opens at 30 to 35 psi (206.7 to 241.2 kPa)
Weight	2.5 lbs (1.14 kg)
Overall Dimensions	3.62 x 3.69 x 7.5 in. (9.19 x 9.37 x 18.05 cm)

Control Box

DOD Drawing Number	70-4196
Voltage	205 to 240 V ac
Frequency	50/60 or 400 Hz
Phase	Single
Current	30 amps
Operation	Manual
Weight	1 lb (0.45 kg)
Overall Dimensions	9.5 x 3.25 x 5.56 in. (24.13 x 8.25 x 20.25 cm)

Power Switch (S22)

DOD Drawing Number	70-4066
--------------------	---------

Fuse

Specification	MIL-F-15160/9
Identifying Number	F09A250V30A

Electric Heater Coolant Thermostat

DOD Drawing Number	70-4074
Manufacturer	Kim Hotstart Manufacturing Co.
Model	KS1012
Switch Type	SPST
Switch Rating	25 amps at 240 V, 50/60 and 400 Hz
Cycling Operation	At -65°F (-53°C) ambient contact to open at 120°F (48°C) (increasing temperature) and close at 100°F (37°C) (decreasing temperature)
Weight	1 lb (0.45 kg)
Overall Dimensions	2.00 x 2.38 x 3.90 in. (5.08 x 6.03 x 9.92 cm)

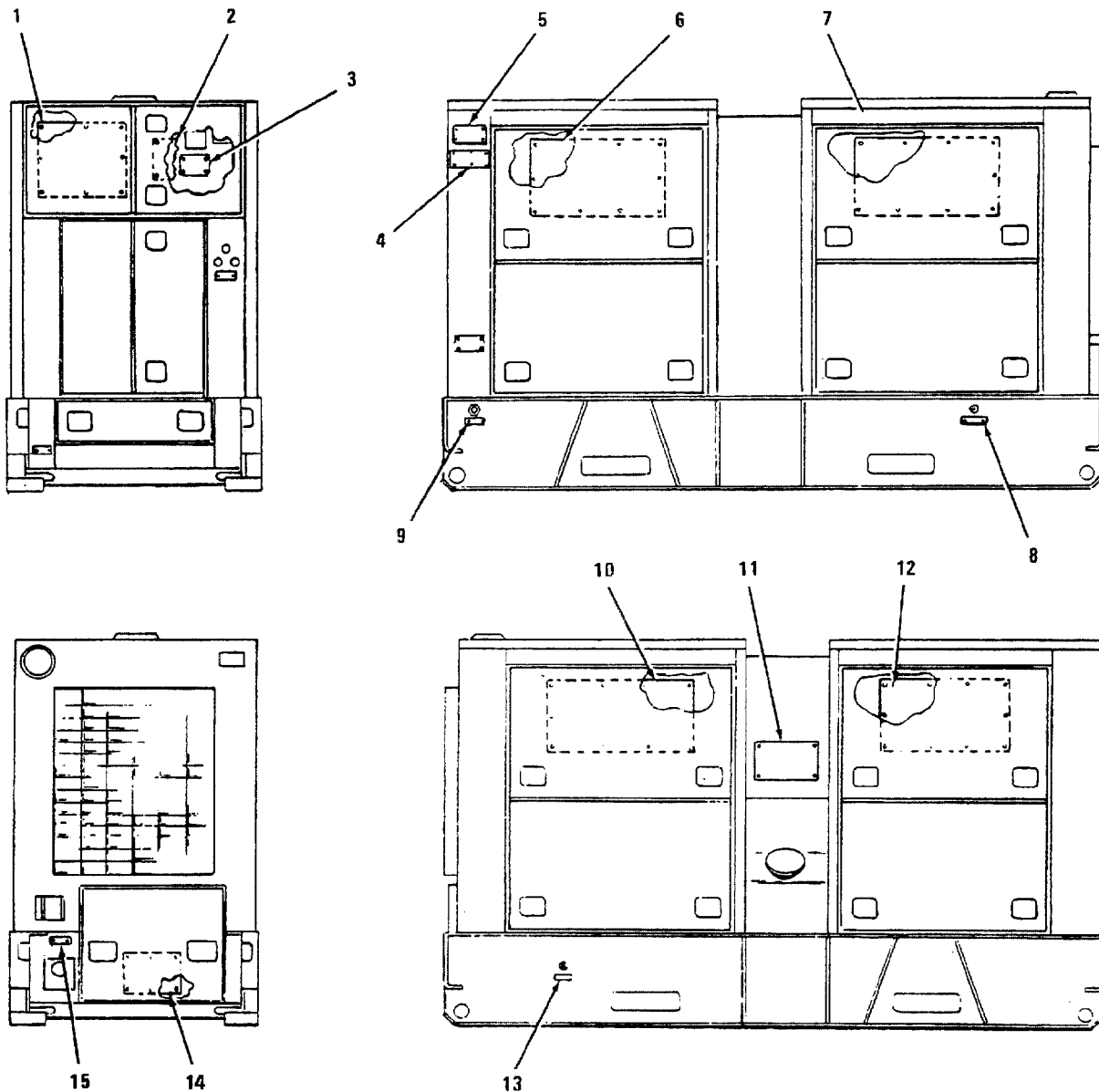

- |  |   |
|--|---|
| 1. OPERATING INSTRUCTIONS PLATE                  | 8. OIL DRAIN IDENTIFICATION PLATE         |
| 2. FUEL SYSTEM DIAGRAM PLATE                     | 9. GROUND IDENTIFICATION PLATE            |
| 3. FAULT INDICATOR MALFUNCTION INSTRUCTION PLATE | 10. DC DIAGRAM PLATE                      |
| 4. SET RATING IDENTIFICATION PLATE               | 11. LIFTING AND TIEDOWN INSTRUCTION PLATE |
| 5. IDENTIFICATION PLATE                          | 12. DC SCHEMATIC PLATE                    |
| 6. AC SCHEMATIC PLATE                            | 13. COOLANT DRAIN IDENTIFICATION PLATE    |
| 7. AC DIAGRAM PLATE                              | 14. BATTERY CONNECTION INSTRUCTION PLATE  |
|  | 15. SLAVE RECEPTACLE IDENTIFICATION PLATE |

Figure 1-3. Location of Identification Plates

Table 1-2. Special Torque Data

COMPONENT	TORQUE FOOT-POUNDS (NEWTON-METERS)
Lubricating Oil Filters	
Drain plugs	100 ±15 (135 ±20)
Valve assemblies	50 ±15 (68 ±20)
Alternator	
Plate mounting nuts	17 ±3 (23 ±4)
Engine	
Fuel line nuts	30 ±5 (40 ±7)
Precombustion chamber nuts	105 ±5 (142 ±7)
Turbocharger mounting nuts	40 ±4 (54 ±5)
Turbocharger clamp	10 (13.6)
Manifolds	32 ±3 (43 ±4)
Heat shield	20 ±3 (27 ±4)
Valve adjusting locknuts	21 ±5 (28 ±7)
Valve cover bolts	96 ±24 inch-pounds (10.9 ±2.8)

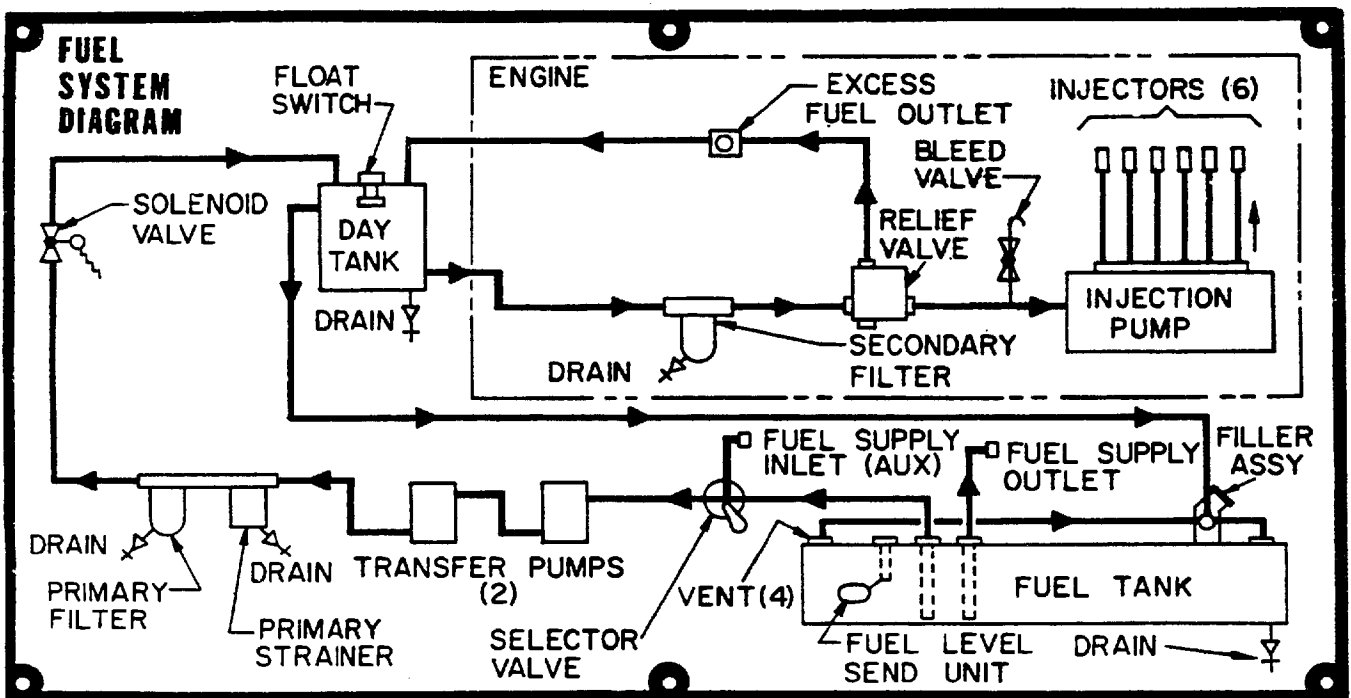
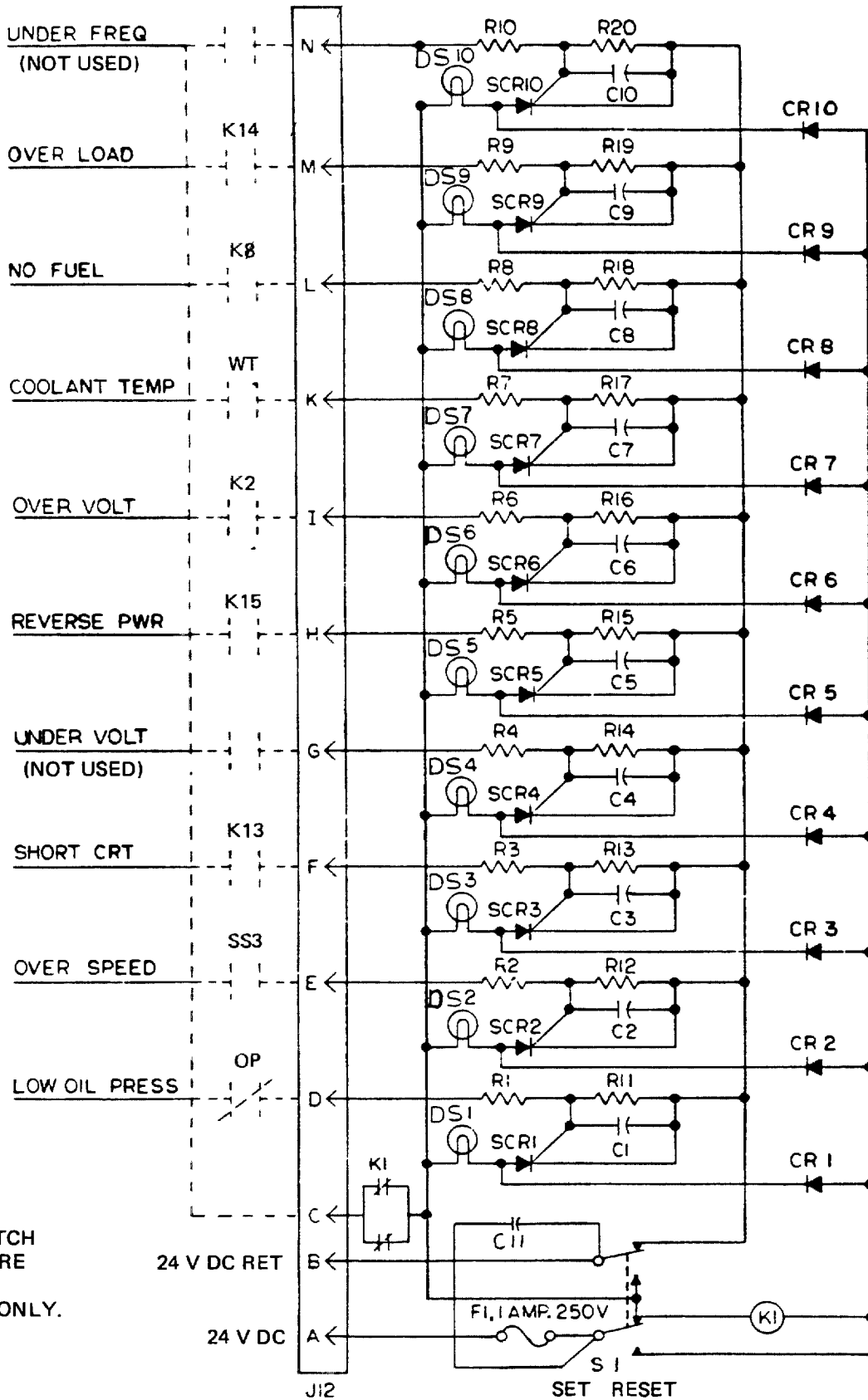

Figure 1-4. Fuel System Diagram



NOTE:  
 DOTTED SWITCH  
 CONTACTS ARE  
 SHOWN FOR  
 REFERENCE ONLY.

Figure 1-5. Fault Indicator Panel A9, Schematic Diagram

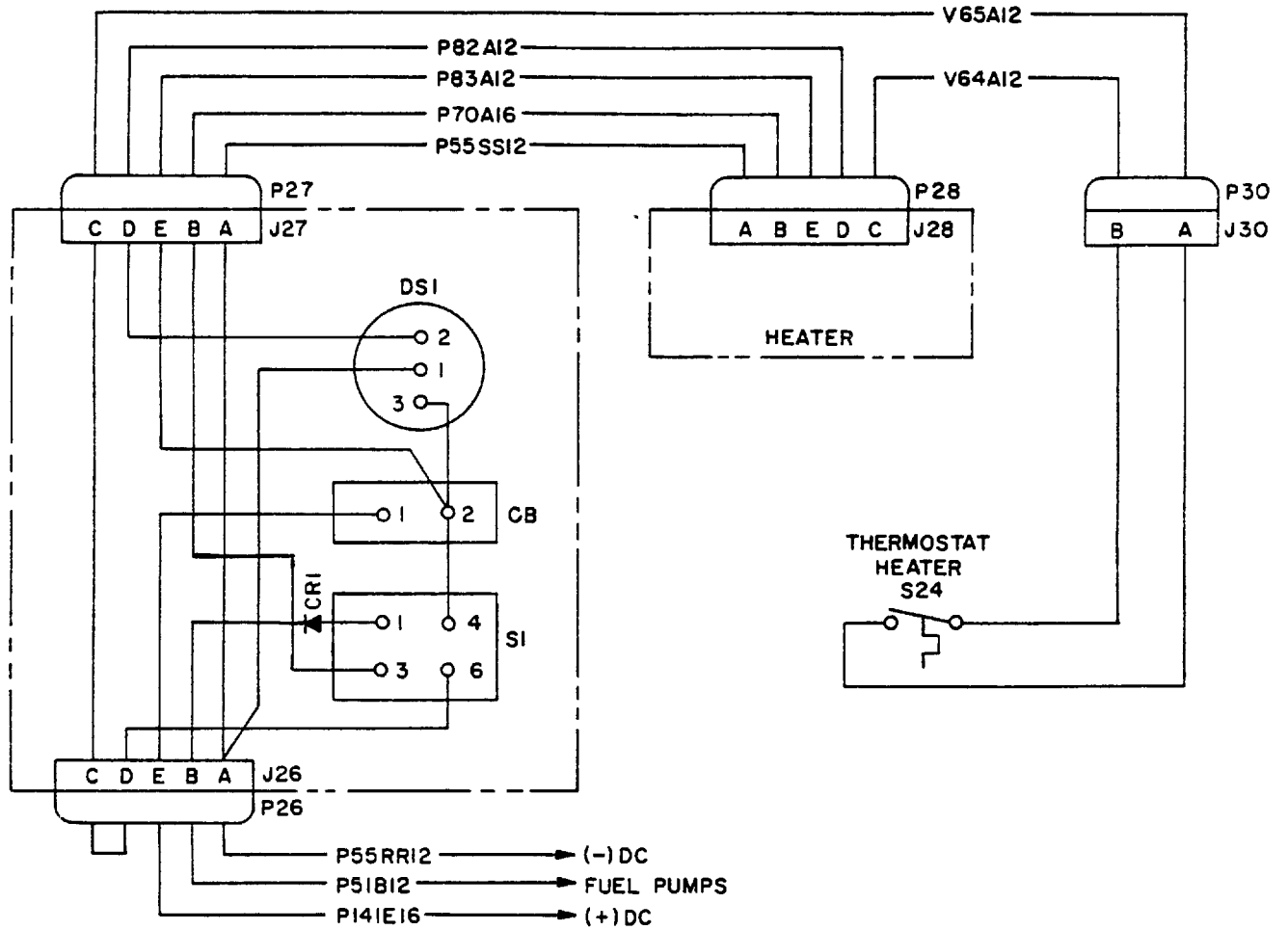

Figure 1-6. Fuel Burning Winterization Kit, Wiring Diagram

AIR FORCE  
 ARMY  
 NAVY  
 MARINE CORPS

TO 35C2-3-442-11  
 TM5-6115-600-12  
 NAVFAC P-8-628-12  
 TM-07464B-12

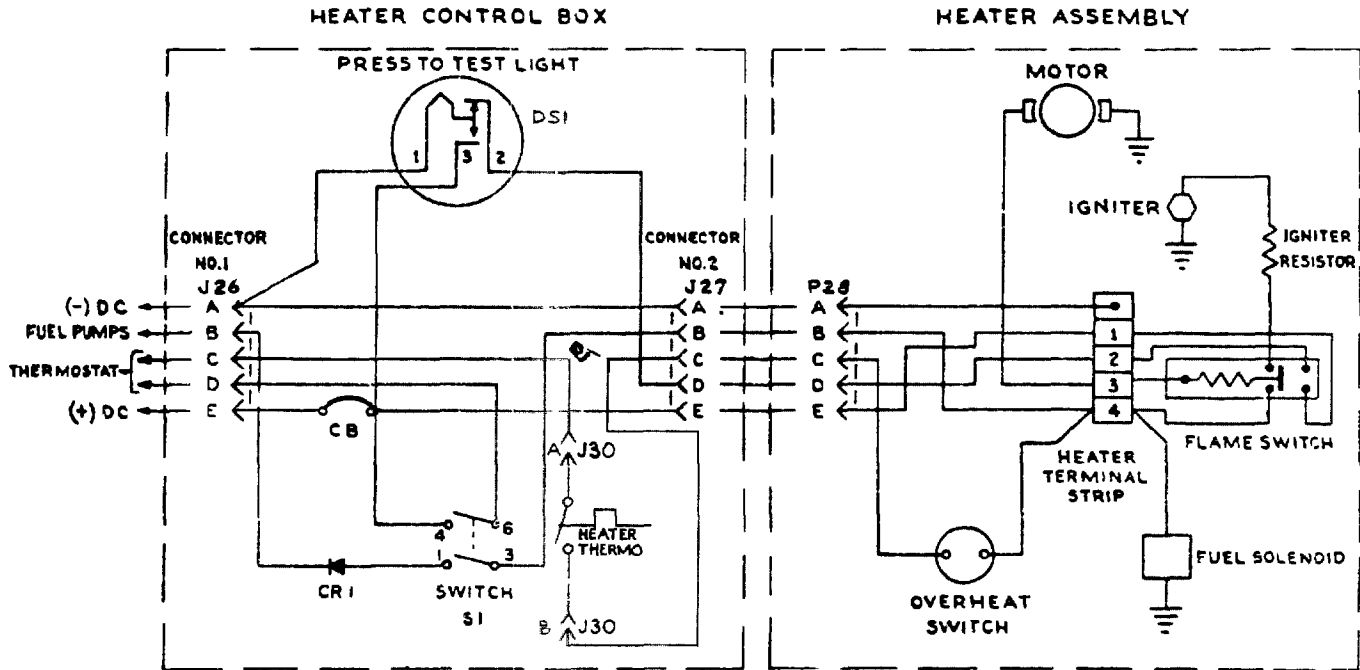

Figure 1-7. Fuel Burning Winterization Kit. Schematic Diagram

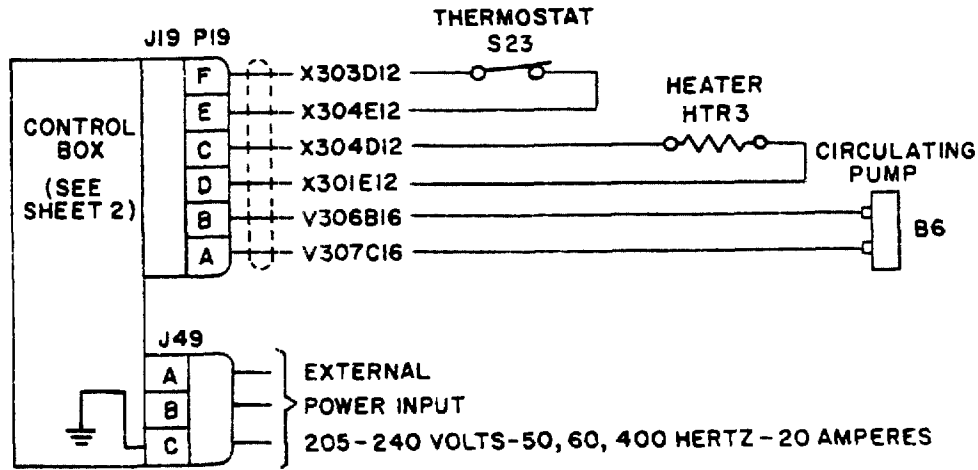

Figure 1-8. Electric Winterization Kit. Wiring Diagram (Sheet 1 of 2)



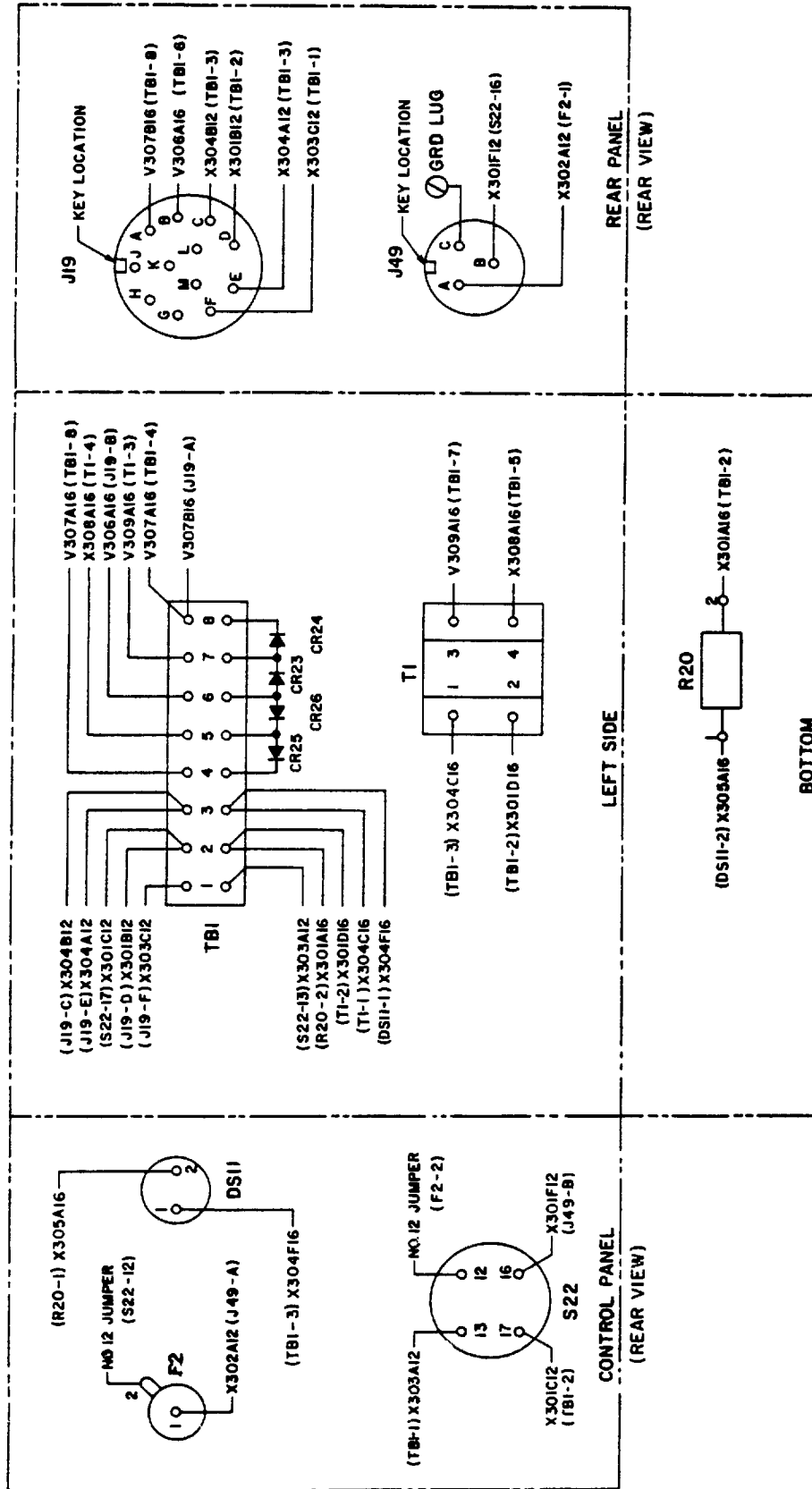

Figure 1-8. Electric Winterization Kit, Wiring Diagram (Sheet 2 of 2)

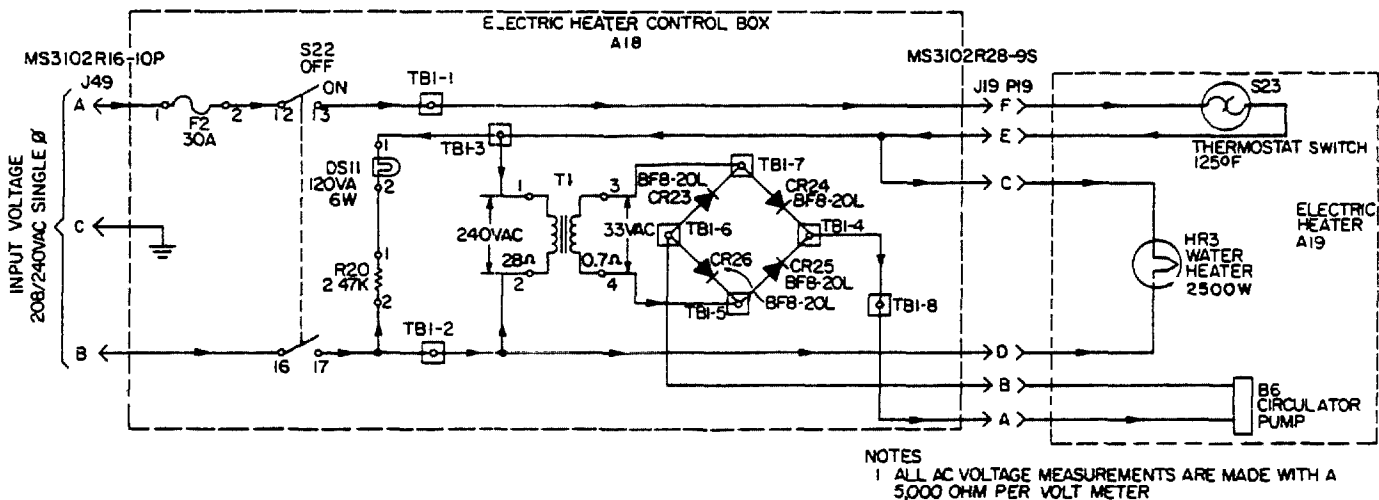

Figure 1-9. Electric Winterization Kit, Schematic Diagram

1-11. DIFFERENCES BETWEEN MODELS.  
This manual covers only generator set,  
Model MEPO07B.

1-12. (A) REPORTING EQUIPMENT  
IMPROVEMENT RECOMMENDATIONS (EIR).  
EIR will be prepared using DA Form  
2407, Maintenance Request.  
Instructions for preparing EIRs are  
provided in TM 38-750, The Army  
Maintenance Management System. EIRs  
should be mailed directly to  
Commander, U.S. Army Troop Support and

Aviation Materiel Readiness Command,  
ATTN: DRSTS-MEM, 4300 Goodfellow  
Boulevard, St. Louis, MO 63120. A  
reply will be furnished directly to  
you.

1-13. (MC) Reporting Equipment  
Deficiency Report (QDR). QDR will be  
prepared in accordance with MCO  
4855.10, utilizing standard form SF  
368. Beneficial suggestions should be  
submitted in accordance with MCO  
1650.17D.

## CHAPTER 2

### OPERATING INSTRUCTIONS

#### Section I. OPERATING PROCEDURES

2-1. GENERAL. This section provides information on how to operate the generator set under normal conditions. Conditions other than those covered in Section III of this chapter and where the generator set is functioning properly are considered normal. The location and function of the controls and indicators necessary for operating the generator set are presented in figures 2-1 through 2-3 and tables 2-1 through 2-3. The purpose of these figures and tables is to enable the operator to become generally familiar with these controls and indicators prior to actually operating the equipment. Take the time to study these figures and tables while inspecting the actual equipment. The knowledge gained will greatly improve your ability to operate the generator set. The step-by-step operating instructions for starting the generator set are presented beginning with figure 2-4. The operating procedures are followed by detailed instructions on how to apply an electrical load to the generator, and then by procedures for stopping the generator set. If equipment malfunctions, refer to the troubleshooting and maintenance procedures in Chapter 3.

2-2. CONTROLS AND INDICATORS. The purpose, location, and normal operating readings or settings of generator set controls and indicators are illustrated in figures 2-1 through 2-3 and described in tables 2-1 through 2-3.

2-3. STARTING THE GENERATOR SET. To start the generator set under usual (normal) conditions, proceed as follows:

#### WARNING

Do not operate the generator set unless it has been properly grounded. Electrical faults (such as leakage paths) in the generator set, feeder lines, or load equipment can cause injury or death by electrocution.

- a. If the unit is to be operated for the first time, ensure that organizational maintenance personnel have performed the procedures described in Chapter 4, Section I, Service Upon Receipt of Equipment.
- b. Perform before operation preventive maintenance checks and services (see table 3-2).
- c. Refer to figure 2-4 and adjust voltage change board as required.
- d. Open control cubicle and air intake doors (figure 1-2) located at the rear of the generator set. Close panel doors of housing.
- e. Set the fuel transfer valve (11, figure 2-1) to desired source of fuel: preferably the, AUXILIARY tank, if it is connected.
- f. Set PARALLEL OPERATION-SINGLE UNIT OPERATION select switch (12, figure 2-2) to SINGLE UNIT OPERATION.
- g. Set VOLTAGE ADJUST-INCREASE control (8, figure 2-2) to lower half of adjustment range.
- h. Depress DC CONTROL CIRCUIT BREAKER (5, figure 2-1) to on position.
- i. Set START-STOP-RUN switch (17, figure 2-2) to RUN.
- j. Set and hold TEST OR RESET switch (7, figure 2-3) in up position.

FUEL INJECTION  
PUMP HOUSING

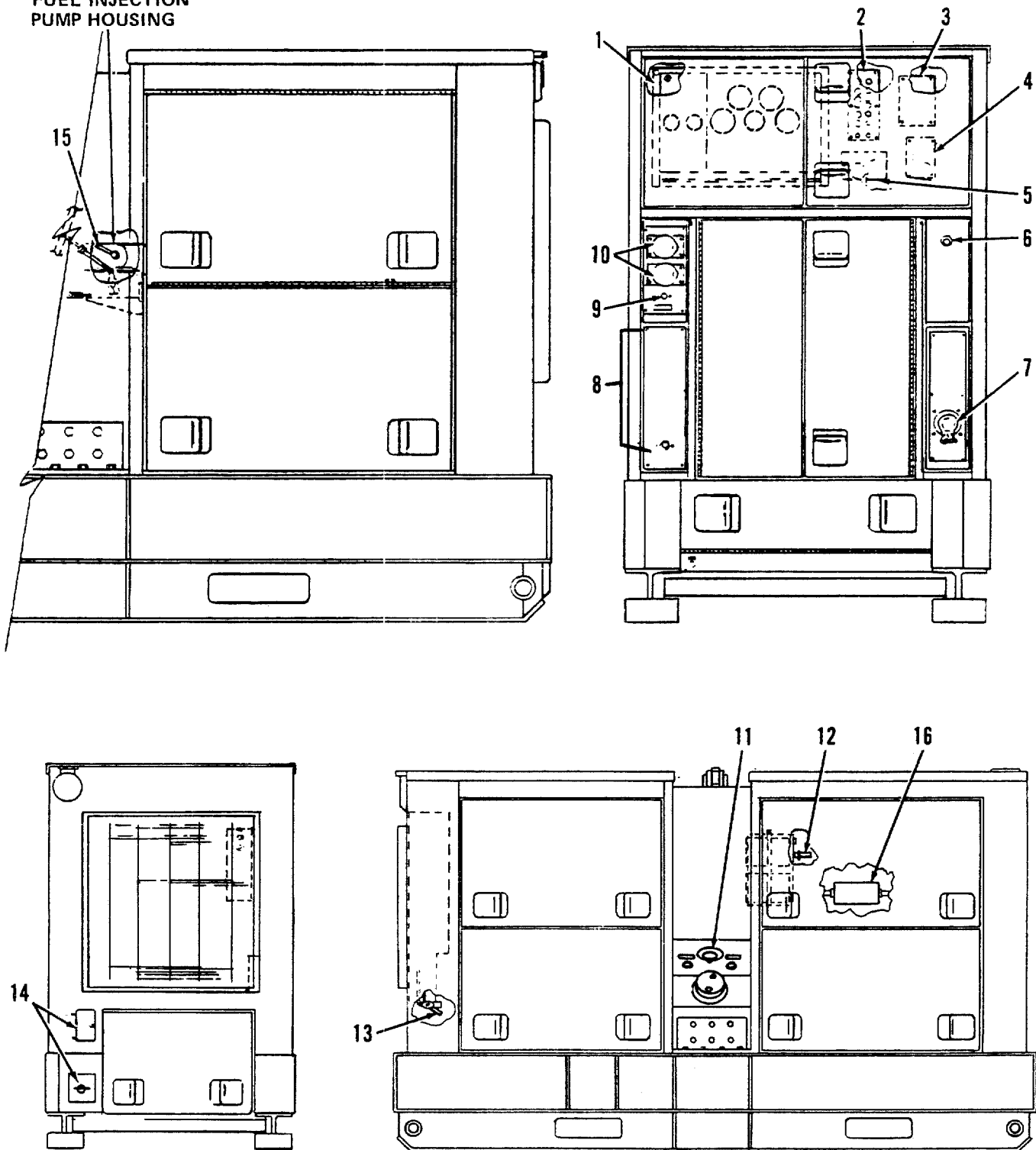

Figure 2-1. Location of Controls, Instruments, and Receptacles

Table 2-1. Generator Set, Controls and Indicators

FIGURE AND INDEX NO.	CONTROL OR INDICATOR	FUNCTION	NORMAL READING/SETTING
2-1, 1	Control Cubicle	Contains major operating controls and indicators for engine and generator (see figure 2-2 and table 2-2 for detailed breakdown of controls and indicators).	--
2-1, 2	Fault Indicator Panel	Indicates what fault has occurred that has caused the engine to shut down or main circuit breaker contacts to open (see figure 2-3 and table 2-3 for detailed breakdown of controls and indicators).	--
2-1, 3	Cover plate	Covers optional access port provided for electric winterization kit control box.	--
2-1, 4	Cover plate	Covers optional access port provided for fuel burning winterization kit control box.	--
2-1, 5	DC CONTROL CIRCUIT BREAKER	Protects as well as energizes dc control circuits. Permits emergency stopping of generator set. Set to trip at 7.5 amperes. Pull for emergency stop.	In

Table 2-1. Generator Set, Controls and Indicators (Cont)

FIGURE AND INDEX NO.	CONTROL OR INDICATOR	FUNCTION	NORMAL READING/SETTING
2-1, 6	Engine manual speed control	Permits manual coarse and fine adjustment of engine speed (actually generator output frequency, directly related to engine speed, is monitored). Coarse adjustment is accomplished by depressing locking button and sliding control in or out as required to increase or decrease engine speed: action is similar to choke control on automobile. Fine adjustment is made by rotating vernier knob clockwise or counterclockwise as required to increase or decrease engine speed.	Mid range
2-1, 7	Plate and sleeve assembly	Covers optional access ports provided for kit installation and feeder lines from load circuits.	--
2-1, 8	Plate	Covers opening provided for kit installation.	--
2-1, 9	Circuit breaker	Protects convenience receptacles (10, figure 2-1). Set to trip at 15 amperes.	--
2-1, 10	Convenience receptacles	Provides access to generator output (120 vac at either 50 or 60 Hertz).	--
2-1, 11	Fuel transfer valve	Permits selection of generator set tank or external fuel supply as main fuel source.	

Table 2-1. Generator Set, Controls and Indicators (Cont)

FIGURE AND INDEX No.	CONTROL OR INDICATOR	FUNCTION	NORMAL READING/SETTING
2-1, 12	Air cleaner condition indicator switch	When air cleaner is clogged this switch trips to energize air cleaner condition indicator light.	
2-1, 13	Radiator shutter control handle	Enables operator to manually close radiator shutter	Closed when coolant is cold and open when hot
2-1, 14	Slave receptacles	Provides access for "jumping" a weak or dead battery. Source of DC current.	
2-1, 15	Manual fuel shut-down lever (located on fuel injection pump housing)	Permits manual shut down of engine by pulling lever toward operator.	Mid position
2-1, 16	Speed switch reset button (located on top of speed switch)	Permits resetting of engine overspeed switch.	

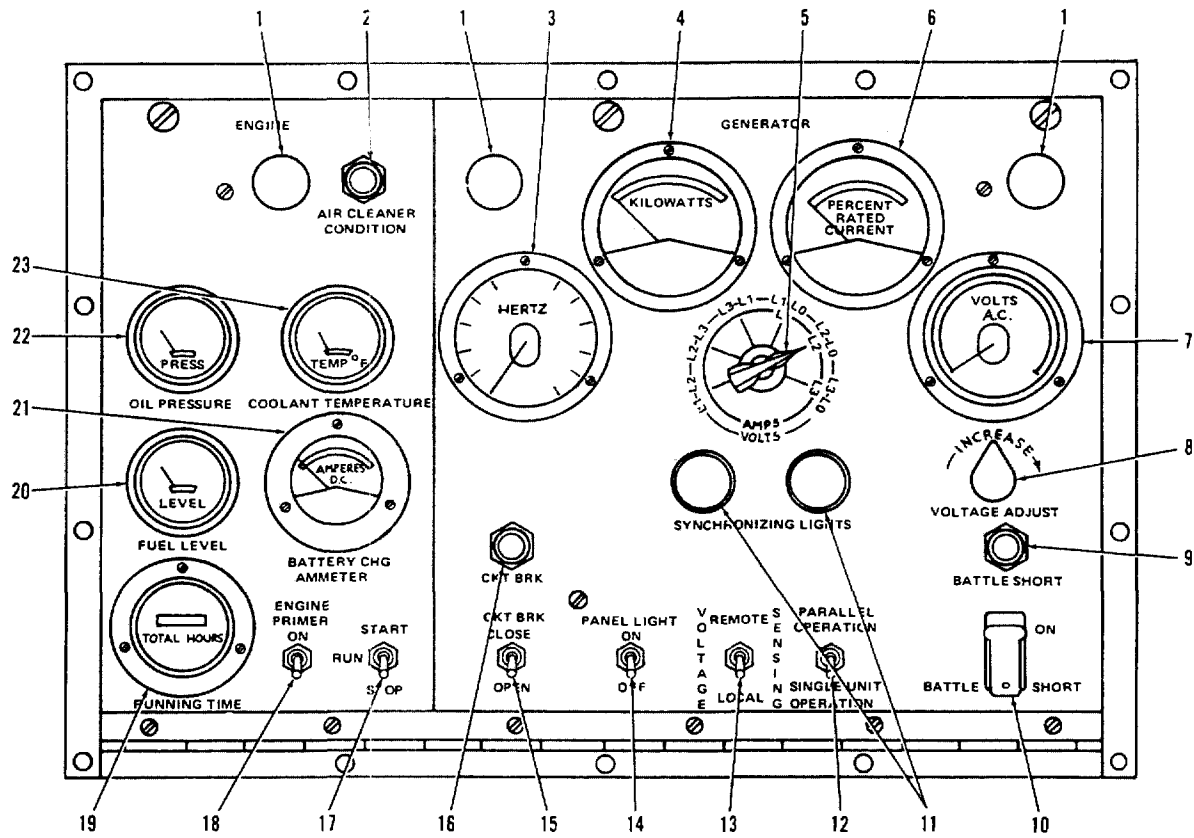

Figure 2-2. Control Cubicle, Controls and Indicators

Table 2-2. Control Cubicle, Controls and Indicators

FIGURE AND INDEX NO.	CONTROL OR INDICATOR	FUNCTION	NORMAL READING/SETTING
2-2, 1	Panel lights	Provides light for using control panel.	--
2-2, 2	AIR CLEANER CONDITION indicator	Lights red to indicate clogged air filter (cleaner).	Off



Table 2-2. Control Cubicle, Controls and Indicators (Cont)

FIGURE AND INDEX NO.	CONTROL OR INDICATOR	FUNCTION	NORMAL READING/SETTING
2-2, 3	HERTZ (frequency) meter	Indicates generator output frequency in Hertz. Scaled to read from 48 53 Hertz (a blue mark highlights 50-cycle point) and from 57 to 62 Hertz (a red mark highlights 60-cycle point).	50 or 60 Hertz
2-2, 4	KILOWATTS meter	Indicates percent of rated power being absorbed by the electrical load. Because rated power, in this case is 100 KW, the meter essentially reads out in kilowatts as well as percent. A blue mark highlights a full-rated load reading of 83 kilowatts for 50-cycle operation and a red mark 100 kilowatts for 60-cycle operation. Scaled to read from 0 to 133 percent.	Anywhere from 0 to 100
2-2, 5	AMPS-VOLTS selector switch	Selects which of the listed phases or windings (L1-L0 or L1, for example) shall be monitored as to current and voltage.	Any one of listed phases or windings
2-2, 6	PERCENT RATED CURRENT meter	Indicates percent of rated current feeding the electrical load, (Rated current at 208 volts, with full rated power and 0.8 power factor is 350 amperes; rated current of 416 volts is 175 amperes.) A blue mark indicates a 100 percent rated current at 50-cycle operation, whereas a red mark indicates 100 percent rated current at 60-cycle operation.	Will vary depending on load circuits

Table 2-2. Control Cubicle, Controls and Indicators (Cont)

FIGURE AND INDEX NO.	CONTROL OR INDICATOR	FUNCTION	NORMAL READING/SETTING
2-2, 7	VOLTS AC meter	Indicates voltage across phase or winding selected by AMPS-VOLTS selector switch.	120, 208, 240, or 416 depending on how generator re-connection panel is wired and which phase or winding is selected.
2-2, 8	VOLTAGE ADJUST-INCREASE control	Adjusts the voltage level output of the generator.	Approximately mid range
2-2, 9	BATTLE SHORT indicator	When lit, indicates generator set is in battle short mode of operation.	Not lit
2-2, 10	BATTLE SHORT ON switch (guard covered)	When set to ON permits operation of the generator set during all fault conditions except engine overspeed and generator short circuit. Guard prevents the accidental operation of this switch.	OFF
2-2, 11	SYNCHRONIZING LIGHTS	Used when paralleling the electrical outputs of two generator sets. the slower these lights blink in unison the closer the generator sets are in phase, frequency, and voltage.	Both lights are out
2-2, 12	PARALLEL OPERATION-SINGLE UNIT OPERATION select switch	When set to PARALLEL OPERATION, this switch activates SYNCHRONIZING LIGHTS.	SINGLE UNIT OPERATION

Table 2-2. Control Cubicle, Controls and Indicators (Cont)

FIGURE AND INDEX NO.	CONTROL OR INDICATOR	FUNCTION	NORMAL READING/SETTING
2-2, 13	VOLTAGE SENSING-REMOTE-LOCAL switch	Determines whether voltage regulator input shall be sensed locally at the generator output or remotely at the load.	If transmission (feeder) lines are relatively short, switch should be set to LOCAL. If lines are excessively long, switch should be set to REMOTE.
2-2, 14	PANEL LIGHT - ON-OFF switch	Turns panel lights on or off.	Depends on available lighting
2-2, 15	CKT BRK-CLOSE-OPEN switch	When set to CLOSE, main circuit breaker closes and output of generator is applied to load circuits.	CLOSE
2-2, 16	CKT BKR indicator	When lit (amber) indicates that contacts of main circuit breaker are closed.	Lit
2-2, 17	START-STOP-RUN switch (spring-loaded)	Begins cranking action of generator set when held in START position. When generator set is operating (and no longer requires cranking) switch is allowed to snap to RUN position. Generator set shuts down when switch is set to STOP position.	RUN
2-2, 18	ENGINE PRIMER-ON switch (spring-loaded)	When held in ON position injects ether (a highly combustible chemical) into input air stream. Used when engine starting is difficult in cold weather.	Off

Table 2-2. Control Cubicle, Controls and Indicators (Cont)

FIGURE AND INDEX NO.	CONTROL OR INDICATOR	FUNCTION	NORMAL READING/SETTING
2-2, 19	RUNNING TIME indicator	Indicates total running time of generator set Used to determine when periodic maintenance shall be done. Returns to zero at 10,000 hours. (Movement in a very small window just to left of digital readout indicates meter is operating.	
2-2, 20	FUEL LEVEL gage	Indicates level of fuel in main fuel tank.	Above empty
2-2, 21	BATTERY CHG AMMETER	Indicates amount of current flowing into batteries (charging: when indication is in green area) or amount flowing out of batteries (discharging: when indication is in red area). Scaled to read from -10 (minus indicates discharging) to +20 amperes.	Slightly above zero and charging (plus)
2-2, 22	OIL PRESSURE gage	Indicates lubricating oil pressure in psig. Scaled to read from 0 to 120 psig.	From 40 to 60 psig
2-2, 23	COOLANT TEMPERATURE indicator	Indicates temperature of engine coolant. Scaled to read from 120 to 240°F (49 to 116°C)	From 180 to 200°F (82 to 93°C)

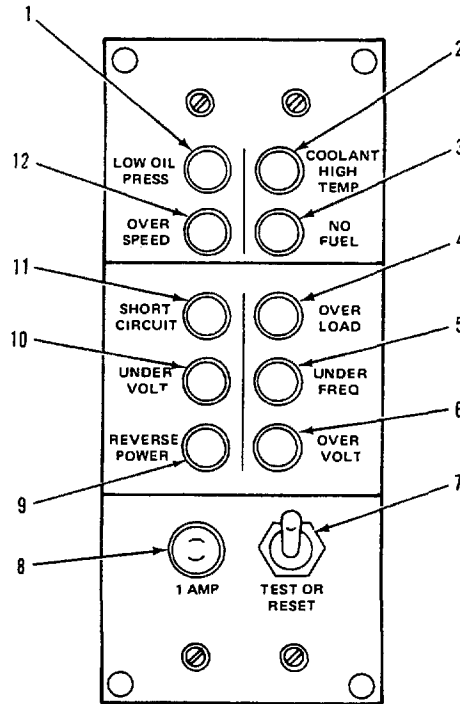

Figure 2-3. Fault Indicator Panel, Controls

Table 2-3. Fault Indicator Panel, Controls and Indicators

FIGURE AND INDEX NO.	CONTROL OR INDICATOR	FUNCTION	NORMAL READING/SETTING
2-3, 1	LOW OIL PRESS indicator	When lit, indicates that engine has shut down due to insufficient lubricating oil pressure.	Not lit
2-3, 2	COOLANT HIGH TEMP indicator	When lit, indicates that engine has shut down due to excessively high coolant temperature- 222 +/--3°F (105 +/--°C)	Not lit
2-3, 3	NO FUEL indicator	When lit, indicates that engine has shut down because there is only enough fuel in day tank for 1 more minute of operation at full rated load. Although engine damage will not occur, the engine's fuel system will have to be bled if fuel runs out.	Not lit

Table 2-3. Fault Indicator Panel, Controls and Indicators (Cont)

FIGURE AND INDEX NO.	CONTROL OR INDICATOR	FUNCTION	NORMAL READING/SETTING
2-3, 4	OVER LOAD indicator	When lit, indicates that current in any of the generator's three windings has exceeded rated current for too great a period of time. The generator can withstand (without damage) small current overloads, but only for short periods of time. (If current exceeds 110 percent of rated value, the protection circuits will "see" this as a short circuit.) Main circuit breaker contacts will open.	Not lit
2-3, 5	UNDER FREQ indicator	Not functional.	
2-3, 6	OVER VOLT indicator	When lit, indicates that output voltage of generator is excessive (153 +3 volts for a 120-volt rated output). Main circuit breaker contacts will open.	Not lit
2-3, 7	TEST OR RESET switch (spring loaded)	Permits testing of all indicator lamps (all should light with switch in up position) or re-setting fault circuits to normal.	Mid position
2-3, 8	1 AMP fuse	Protects components of FAULT INDICATOR circuits against excessive current.	
2-3, 9	REVERSE POWER fault indicator	When lit, indicates that power (possibly damaging) is flowing into generator and is at least 20 +/-3 percent of rated output. Main circuit breaker contacts will open.	Not lit

Table 2-3. Fault Indicator Panel, Controls and Indicators (Cont)

FIGURE AND INDEX NO.	CONTROL OR INDICATOR	FUNCTION	NORMAL READING/SETTING
2-3, 10	UNDER VOLT fault indicator	Not functional.	--
2-3, 11	SHORT CIRCUIT fault indicator	When lit, indicates that short circuit condition exists in generator output or load circuits. Main circuit breaker contacts will open. BATTLE SHORT switch will not override this condition.	Not lit
2-3, 12	OVERSPEED fault indicator	When lit, indicates that engine has shut down because engine speed was excessive. BATTLE SHORT switch will not override this condition.	Not lit

Each fault indicator should light. Check and replace defective lamp or fuse as required

k. Allow TEST OR RESET switch to return to mid-position. Each fault indicator, with the exception of LOW OIL PRESSURE, should go out. When engine has started LOW OIL PRESSURE indicator should also go out.

NOTE

If NO FUEL indicator stays lit, refill set or auxiliary tank. Position BATTLE SHORT switch to ON (fuel pump will run to fill the day tank). Set TEST OR RESET switch to up position and then release; NO FUEL indicator should go out.

l. Set CKT BRK-CLOSE-OPEN switch (15, figure 2-2) to OPEN.  
 m. Push and release AIR CLEANER CONDITION indicator (2, figure 2-2), BATTLE SHORT indicator (9, figure 2-2), and CKT BRK indicator (16, figure 2-2). Each should light and go out when released.

(1) If AIR CLEANER CONDITION indicator remains lit, service the air cleaner. Refer to paragraph 3-16a.

(2) If CKT BRK indicator remains lit after setting CKT BRK switch to OPEN, refer to appropriate level of maintenance as described in the Maintenance Allocation Chart (MAC).

n. Depress lock button on manual engine speed control (6, figure 2-1) and set to mid-range position.

o. Refer to figure 2-5 for engine starting procedures.

2-4. OPERATING THE GENERATOR SET (SINGLE UNIT). To operate the generator set as a single unit, proceed as follows:

a. Ensure that PARALLEL OPERATION-SINGLE UNIT OPERATION switch (12, figure 2-2) is set to SINGLE UNIT OPERATION.

b. Refer to figure 2-6 for single unit operating procedures.

c. When in operation, the generator set should be monitored periodically (at least once an hour) for signs of possible future malfunctions.

d. After warm-up, lubricating oil pressure should remain virtually constant. Check and record level of lubricating oil while engine is running normally. If any significant changes occur in oil pressure, maintenance personnel should be notified.

e. Check and record coolant temperature of normally running engine. Notify maintenance personnel if coolant temperature changes significantly.

f. Learn the sounds of a normally running generator set so that any unusual sounds indicating the possible start of a malfunction may be detected early enough to avoid major damage.

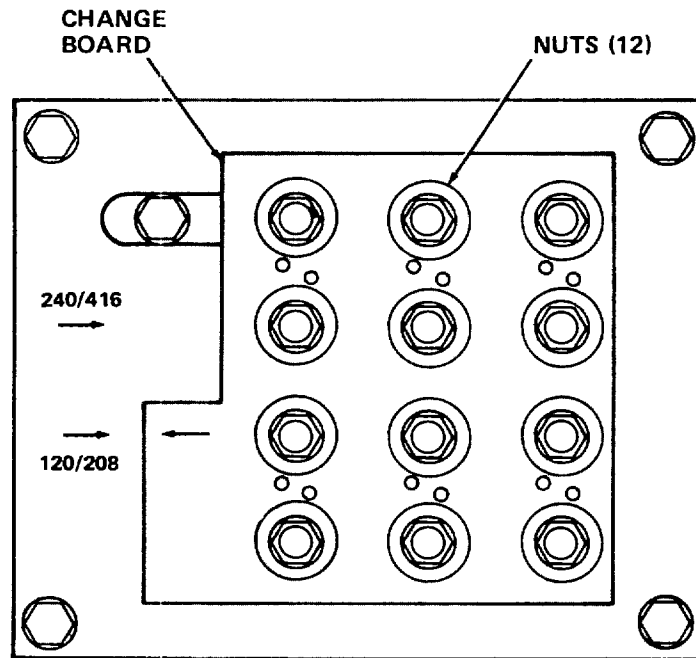

- STEP 1. DISCONNECT TRANSPARENT COVER BY LOOSENING SIX QUICK-RELEASE FASTENERS.
- STEP 2. REMOVE TWELVE NUTS. MOVE CHANGE BOARD UP OR DOWN TO ALIGN CHANGE BOARD ARROW WITH REQUIRED VOLTAGE ARROW. TIGHTEN TWELVE NUTS TO SECURE.
- STEP 3. POSITION AND SECURE TRANSPARENT COVER WITH SIX QUICK-RELEASE FASTENERS.

Figure 2-4. Voltage Conversion



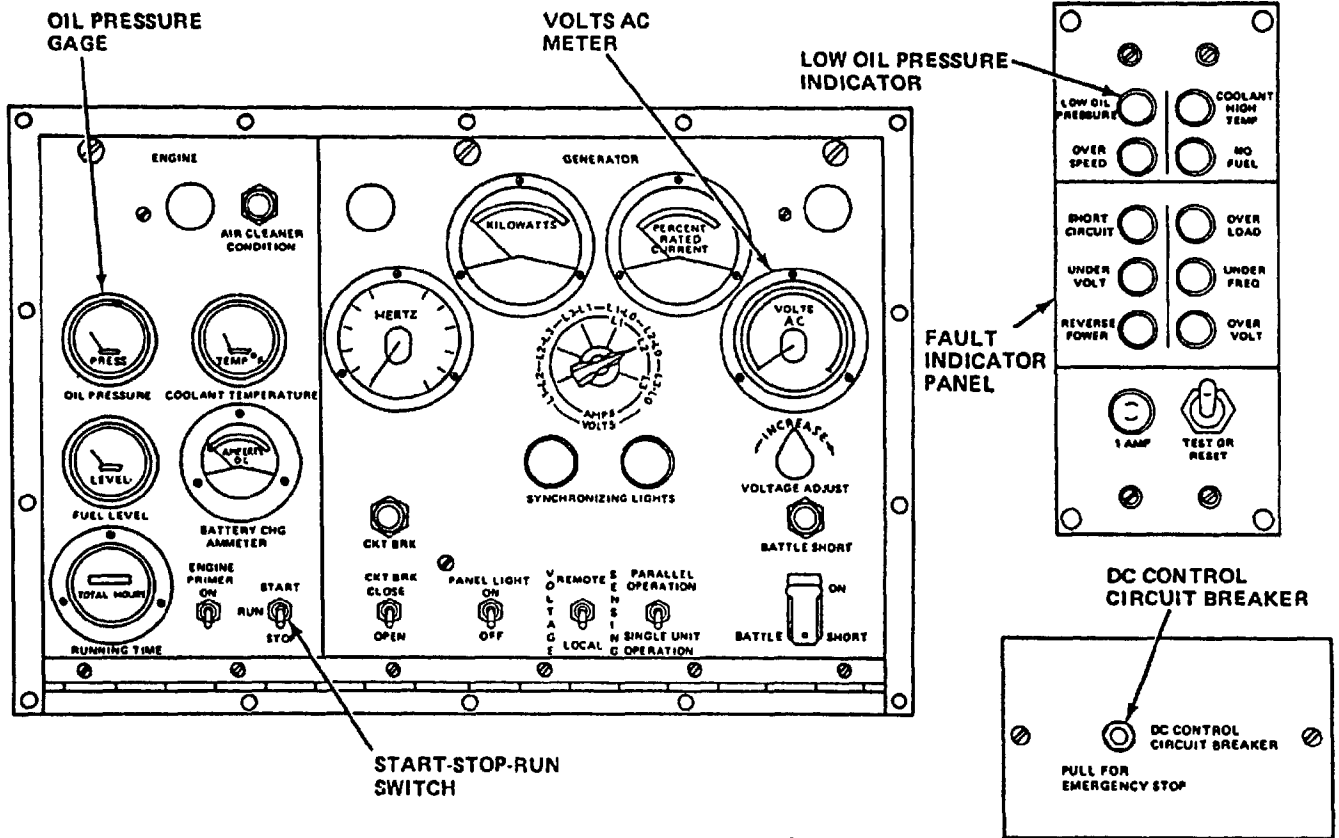

STEP 1. DEPRESS DC CONTROL CIRCUIT BREAKER TO ON.

CAUTION

DO NOT CRANK ENGINE IN EXCESS OF 15 SECONDS AT A TIME. ALLOW STARTER TO COOL A MINIMUM OF 3 MINUTES BETWEEN CRANKINGS.

WARNING

NOISE HAZARD

OPERATION OF THIS EQUIPMENT PRESENTS A NOISE HAZARD TO PERSONNEL IN THE AREA. THE NOISE LEVEL EXCEEDS THE ALLOWABLE LIMITS FOR UNPROTECTED PERSONNEL. WEAR EAR MUFFS OR EAR PLUGS.

STEP 2. SET AND HOLD START-STOP-RUN SWITCH TO START UNTIL ENGINE STARTS (AT WHICH POINT THE OIL PRESSURE GAGE INDICATES AT LEAST 25 PSIG, VOLTS AC METER INDICATES PRESENCE OF VOLTAGE, AND LOW OIL PRESSURE INDICATOR GOES OUT). USE SLAVE RECEPTACLE (SR1 OR SR2) WHEN EXTRA CRANKING POWER IS REQUIRED.

STEP 3. RELEASE START-STOP-RUN SWITCH. POSITION SWITCH TO RUN.

Figure 2-5. Starting Generator Set, Usual Conditions

AIR FORCE  
ARMY  
NAVY  
MARINE CORPS

T.O. 35C2-3-442-11  
TM5-6115-600-12  
NAVFAC P-8-628-12  
TM-07464B-12

COOLANT  
TEMPERATURE  
GAGE

HERTZ  
(FREQUENCY)  
METER

KILOWATTS  
METER

AMPS-VOLTS  
SELECTOR SWITCH

PERCENT RATED  
CURRENT

VOLTS AC  
METER

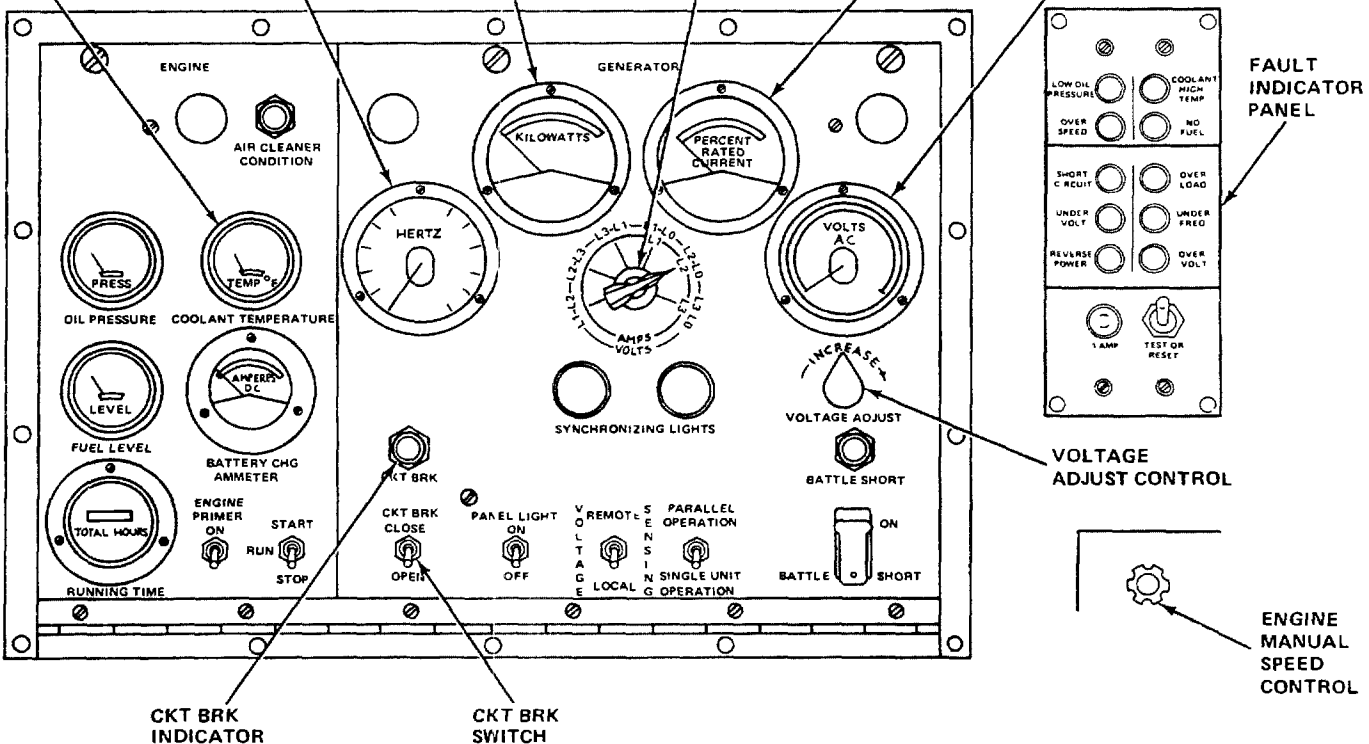

- STEP 1. START GENERATOR SET (REFER TO FIGURE 2-5).
- STEP 2. POSITION AMPS-VOLTS SELECTOR SWITCH TO REQUIRED POSITION. ROTATE VOLTAGE ADJUST CONTROL TO OBTAIN REQUIRED VOLTAGE AS INDICATED ON VOLTS AC METER.
- STEP 3. DEPRESS LOCKING BUTTON AND SLIDE ENGINE MANUAL SPEED CONTROL IN OR OUT TO OBTAIN APPROXIMATE RATED FREQUENCY; ROTATE VERNIER KNOB CLOCKWISE OR COUNTERCLOCKWISE TO OBTAIN RATED FREQUENCY.

NOTE

IF NECESSARY, LOAD MAY BE APPLIED IMMEDIATELY.

- STEP 4. OPERATE ENGINE AT LEAST 5 MINUTES FOR WARM-UP.
- STEP 5. APPLY LOAD BY HOLDING CKT BRK SWITCH TO CLOSE UNTIL CKT BRK INDICATOR LIGHTS. RELEASE SWITCH.
- STEP 6. OBSERVE VOLTS AC METER AND HERTZ (FREQUENCY) METER. IF NECESSARY, READJUST TO OBTAIN DESIRED OPERATING RANGES.
- STEP 7. OBSERVE KILOWATTS METER. IF MORE THAN RATED KW IS INDICATED, REDUCE LOAD.
- STEP 8. ROTATE AMPS-VOLTS SELECTOR SWITCH TO EACH PHASE POSITION AND MONITOR PERCENT RATED CURRENT METER. IF MORE THAN RATED LOAD IS INDICATED (SEE TABLE 1-1) FOR ANY PHASE POSITION, REDUCE OR RE-APPORTION LOAD.
- STEP 9. PERIODICALLY (NOT LESS THAN ONCE PER HOUR) MONITOR ENGINE AND GENERATOR INDICATORS TO ENSURE CONTINUED OPERATION.
- STEP 10. PERFORM "DURING OPERATION" PREVENTIVE CHECKS AND SERVICES AS SPECIFIED IN TABLE 3-2.

Figure 2-6. Single Unit Operation

## 2-5. OPERATING THE GENERATOR (UNITS IN PARALLEL).

### NOTE

These procedures assume that one generator set is on-line (operating and connected to the distribution feeder lines through switch gear). The set that is to be paralleled shall be designated the "incoming set".

Refer to figures 2-7 and 2-8 to set up the generator sets for parallel operation, and to figure 2-9 for removing a generator set from parallel operation. When operated in parallel, generator sets must have the same output voltage, frequency, phase relation, and phase sequence before they can be connected to a common distribution bus. Severe damage may occur to the generator sets if these requirements are not met. Adjusting engine speed of the incoming set while observing output frequency and the SYNCHRONIZING LIGHTS will bring the phase and frequency into exact agreement. As the phase and frequency approach the same value, the SYNCHRONIZING LIGHTS will gradually turn on and off. When the blinking slows to a rate of once or less per second, close the main circuit breaker of the incoming set while the SYNCHRONIZING LIGHTS are at a point of being dark. Phase sequence has to do with the order in which the generator windings are connected. If phase sequence is not correct, the

SYNCHRONIZING LIGHTS will not blink on and off together.

When the incoming set is first connected to the load (through appropriate switch gear) the following may occur: if the phase sequence, voltage, frequency, phase and engine performance are the same, the changeover will be smooth with only the slightest hesitation in engine speed; if each output is slightly out of phase, one of the engines will "shudder" at the point of changeover; if the phase sequence or voltage levels are incorrect, the reverse power relay will trip on one of the generator sets and open its main circuit breaker contactors; if the incoming generator set loses speed significantly or almost stalls, the incoming engine may be defective.

### CAUTION

Should either generator set lose speed, "buck", or "shudder", when the incoming set is connected to the distribution feeder lines, immediately flip CKT BRK switch of incoming set to OPEN and recheck paralleling set-up procedures.

2-6. STOPPING GENERATOR SET OPERATION. To stop generator set operation, refer to figure 2-10.

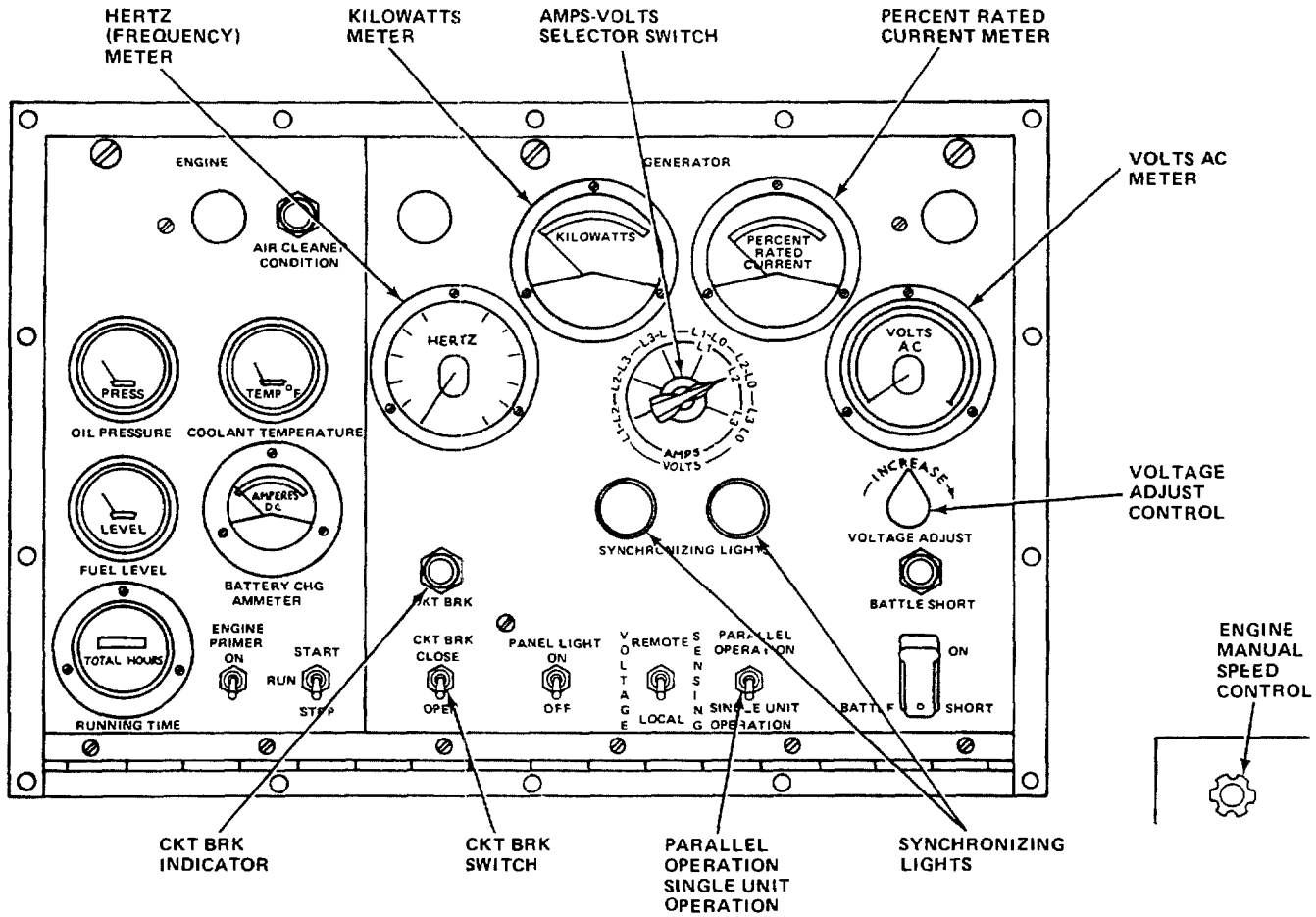

WARNING

WHEN PERFORMING STEP 1, MAKE CERTAIN INCOMING SET IS SHUT DOWN AND THAT THERE ARE NO VOLTAGES AT SWITCH GEAR TERMINALS BEING CONNECTED TO INCOMING SET. DO NOT TAKE ANYBODY'S WORD FOR IT! CHECK IT OUT FOR YOURSELF! THERE COULD BE DANGEROUS AND POSSIBLY LETHAL VOLTAGES PRESENT. TAKE EXTREME CARE NOT TO CROSS L0 (NEUTRAL) WITH ANY OF THE OTHER PHASES (L1, L2, OR L3).

- STEP 1. CONNECT THE INCOMING SET AS SHOWN IN FIGURE 2-8.
- STEP 2. MAKE CERTAIN THAT VOLTAGE CHANGE (RECONNECTION) BOARD OF INCOMING SET IS SETUP FOR SAME OUTPUT VOLTAGE AS ON-LINE SET (SEE FIGURE 2-4).
- STEP 3. SET CTK BRK SWITCH ON INCOMING SET TO OPEN. WHEN INCOMING SET CIRCUIT BREAKER IS OPEN (CTK BRK INDICATOR WILL BE OUT), OPERATE LOAD SWITCH GEAR SO THAT ON-LINE OUTPUT VOLTAGE IS PRESENT AT VOLTAGE CHANGE BOARD OF INCOMING SET.
- STEP 4. SET PARALLEL OPERATION-SINGLE UNIT OPERATION SWITCH ON BOTH SETS TO PARALLEL OPERATION.
- STEP 5. START INCOMING SET. ON-LINE SET SHOULD BE IN OPERATION ALREADY.
- STEP 6. AFTER 5-MINUTE WARM-UP, VARY VOLTAGE ADJUST CONTROL ON INCOMING SET UNTIL OUTPUT VOLTAGES OF BOTH SETS ARE EQUAL.

Figure 2-7. Setting up for Parallel Operation (Sheet 1 of 2)

CAUTION

IF SYNCHRONIZING LIGHTS DO NOT BLINK ON AND OFF IN UNISON, PHASE SEQUENCE IS INCORRECT. SHUT DOWN INCOMING SET AND RECHECK CABLING TO AND FROM INCOMING SET.

- STEP 7. INCOMING SET. POSITION ENGINE MANUAL SPEED CONTROL UNTIL SYNCHRONIZING LIGHTS BLINK ON AND OFF AS SLOWLY AS POSSIBLE.
- STEP 8. WITH ONE HAND ON CKT BRK SWITCH, ADJUST ENGINE MANUAL SPEED CONTROL VERNIER KNOB UNTIL SYNCHRONIZING LIGHTS DIM GRADUALLY FROM FULL ON TO FULL OFF AS SLOWLY AS POSSIBLE. JUST AS SYNCHRONIZING LIGHTS DIM TO OUT, SET AND HOLD CKT BRK SWITCH TO CLOSE. WHEN CKT BRK INDICATOR COMES ON, RELEASE SWITCH.
- STEP 9. BOTH SETS: CHECK THAT READINGS OF PERCENT RATED CURRENT AND KILOWATTS METERS ARE WELL WITHIN 20 PERCENT OF EACH OTHER. IF NOT, INCREASE ENGINE POWER OF SET WITH LOWER READINGS (BY ADJUSTING ENGINE MANUAL SPEED CONTROL TO INCREASE SPEED) UNTIL READINGS ARE JUST ABOUT EQUAL.

NOTE

THE DIVISION OF KILOWATT LOAD IS ALSO DEPENDENT ON THE FREQUENCY DROOP OF THE TWO SETS AND MUST BE ADJUSTED AT THE NEXT HIGHER LEVEL OF MAINTENANCE. IF THE CURRENT DOES NOT DIVIDE AS DESCRIBED ABOVE, ADJUST REACTIVE CURRENT SHARING CONTROL R29 LOCATED AT RIGHT SIDE OF SPECIAL RELAY BOX FOR EQUAL READING ON BOTH PERCENT RATED CURRENT METERS.

- STEP 10. INCOMING SET: READJUST VOLTAGE AND FREQUENCY OF OUTPUT UNTIL EQUAL TO OUTPUT OF ON-LINE SET.

Figure 2-7. Setting up for Parallel Operation (Sheet 2 of 2)

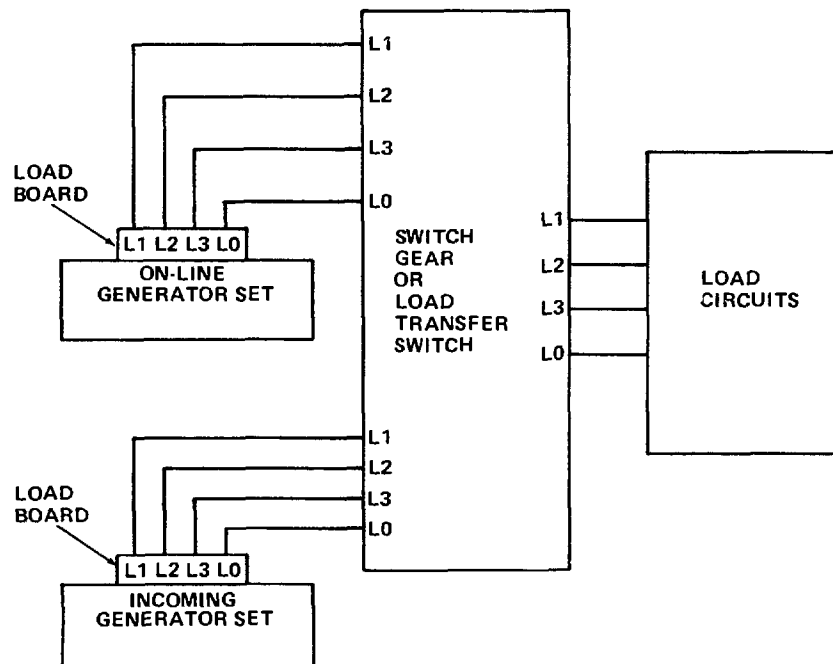
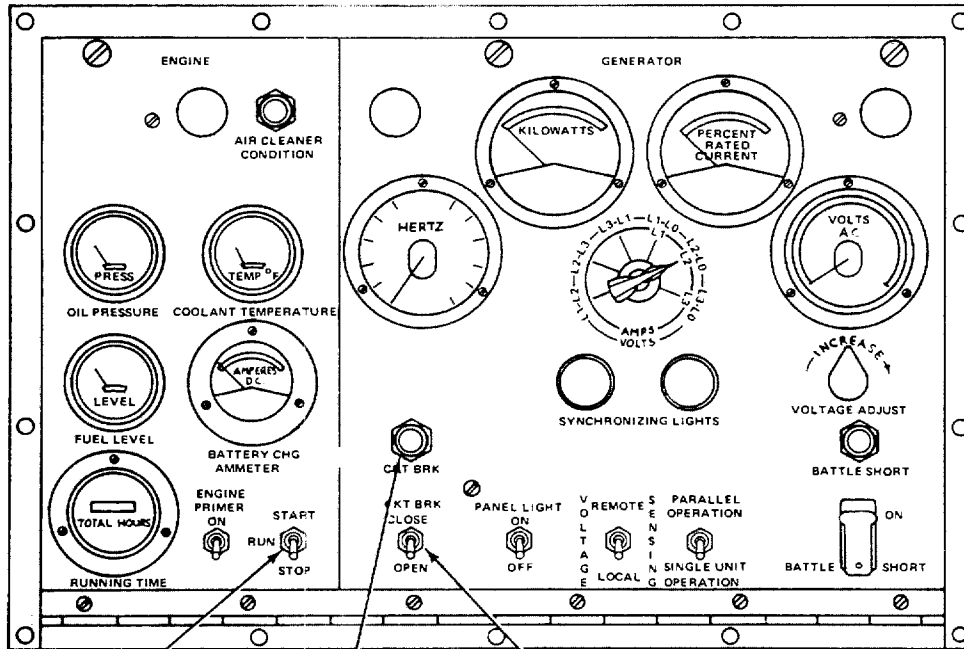

Figure 2-8. Parallel Operation Connection Diagram



START-STOP-RUN SWITCH

CKT BRK INDICATOR

CKT BRK SWITCH

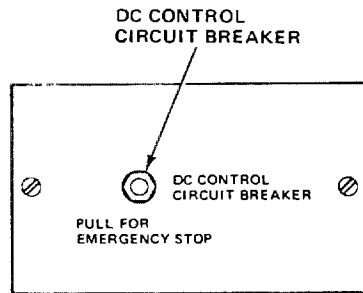

CAUTION

PRIOR TO REMOVAL OF GENERATOR SET(S) FROM PARALLEL OPERATION MAKE SURE LOAD DOES NOT EXCEED FULL LOAD RATING OF GENERATOR SET(S) REMAINING ON THE LINE.

- STEP 1. OUTGOING SET: POSITION AND HOLD CKT BRK SWITCH TO OPEN UNTIL CKT BRK INDICATOR GOES OUT. RELEASE SWITCH.
- STEP 2. OUTGOING SET: ALLOW ENGINE TO OPERATE WITH NO LOAD FOR ABOUT 5 MINUTES.
- STEP 3. OUTGOING SET: PULL DC CONTROL CIRCUIT BREAKER TO OFF.
- STEP 4. OUTGOING SET: SET START-STOP-RUN SWITCH TO STOP.

WARNING

MAKE CERTAIN OUTGOING SET IS SHUT DOWN AND THERE ARE NO VOLTAGES AT SWITCH GEAR TERMINALS CONNECTED TO OUTGOING SET. DO NOT TAKE ANYBODY'S WORD FOR IT -- CHECK IT OUT FOR YOURSELF!

- STEP 5. DISCONNECT CABLES GOING FROM OUTGOING SET TO LOAD SWITCH GEAR.

Figure 2-9. Removing Generator Set From Parallel Operation

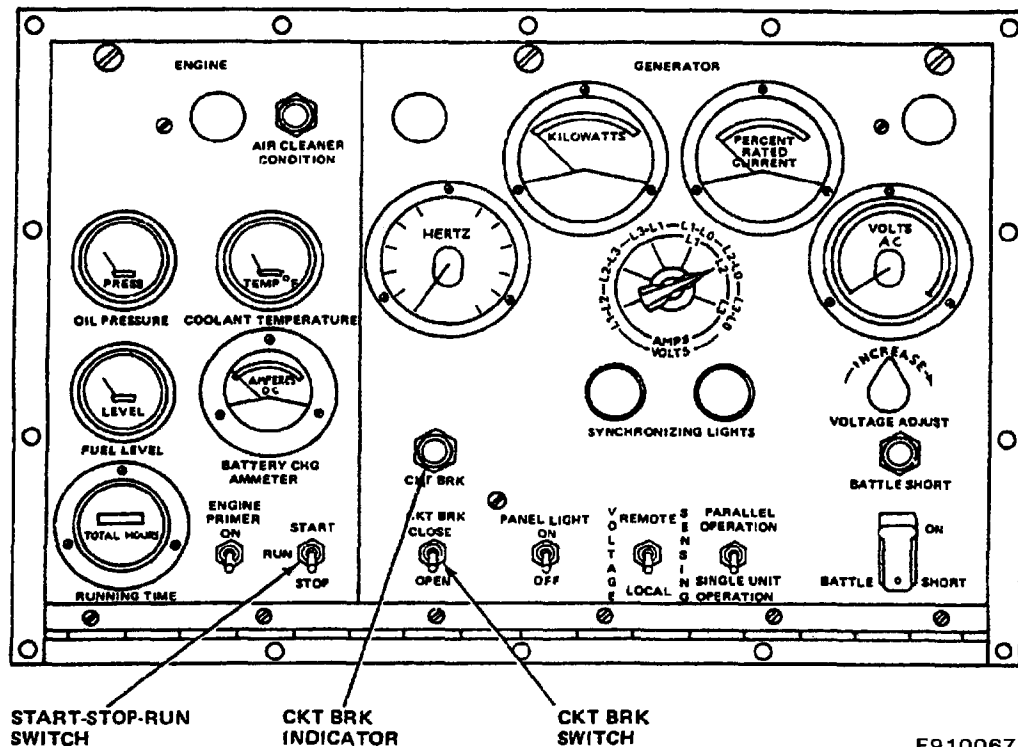

F9100671

- STEP 1. SET CKT BRK SWITCH TO OPEN UNTIL CKT BRK INDICATOR GOES OUT: THEN RELEASE CKT BRK SWITCH.
- STEP 2. ALLOW ENGINE TO COOL DOWN BY OPERATING AT NO LOAD FOR 5 MINUTES.
- STEP 3. SET START-STOP-RUN SWITCH TO STOP.
- STEP 4. OPEN D.C. CONTROL CIRCUIT BREAKER.
- STEP 5. CLOSE ALL GENERATOR SET DOORS.

Figure 2-10. Stopping Generator Set Operation

## Section II. OPERATION OF AUXILIARY EQUIPMENT

2-7. GENERAL. This section provides information on how to operate the auxiliary fuel burning winterization kit and the auxiliary electric winterization kit.

2-8. FUEL BURNING WINTERIZATION KIT. The fuel burning winterization kit preheats the engine coolant and lubricating oil when ambient (outside) temperatures fall below  $-25^{\circ}\text{F}$  ( $-31^{\circ}\text{C}$ ) and as far down as  $-65^{\circ}\text{F}$  ( $-53.9^{\circ}\text{C}$ ). With coolant and

lubricating oil kept close to operating temperature, it is possible to start the usually hard starting diesel engine during extremely cold weather conditions. If outside temperature is  $-25^{\circ}\text{F}$  ( $-31^{\circ}\text{C}$ ) or less, an external source of 24 vdc capable of cranking the engine may be required. All housing and doors and the radiator shutter must be closed while the engine is being preheated. To preheat the engine using the fuel burning heater, proceed as follows:

- a. Close coolant drain valve (33, figure 5-1) and then open coolant valves (15 and 28).
- b. Open fuel shutoff valve (39).
- c. Remove two screws (54) and lockwashers (55) and remove heater exhaust plate (56).
- d. Close housing doors and radiator shutter.
- e. If outside temperature less than -25°F (-31°C) and if the condition of the starting batteries is not up to full capacity, an external 24 V dc source may be required to ignite the fuel in the kit. This 24 V dc source may be applied at either of two slave receptacles (14, figure 2-1) located in the rear, lower left area of the generator.
- f. Refer to figure 2-11 and table 2-4 for the location and function of the fuel burning winterization controls and indicators.
- g. Refer to figure 2-12 for step-by-step operating instructions.
- h. If use of fuel burning heater is not expected in the near future, close the fuel shutoff and coolant valves. Reinstall the heater exhaust plate.

**2-9. ELECTRIC WINTERIZATION KIT.** The electric winterization kit preheats the engine coolant and lubricating oil when ambient (outside) temperatures are between -25°F (-31°C) and -65°F (-53.9°C). With coolant and lubricating oil kept close to operating temperatures, it is possible to start the diesel engine during extremely cold weather conditions. If outside temperature is -25°F (-31°C) or less, an external source of 24 V dc capable of cranking the engine may be required. All housing doors and the radiator shutter must be closed while the engine is being preheated. To preheat the engine using the electric heater, proceed as follows:

- a. Close coolant drain valve (47, figure 5-9).
- b. Open coolant valves (10 and 50).
- c. Close housing doors and radiator shutter.
- d. Refer to figure 2-13 and table 2-5 for the location and function of operating controls and indicators.
- e. Refer to figure 2-14 for step-by-step operating instructions.

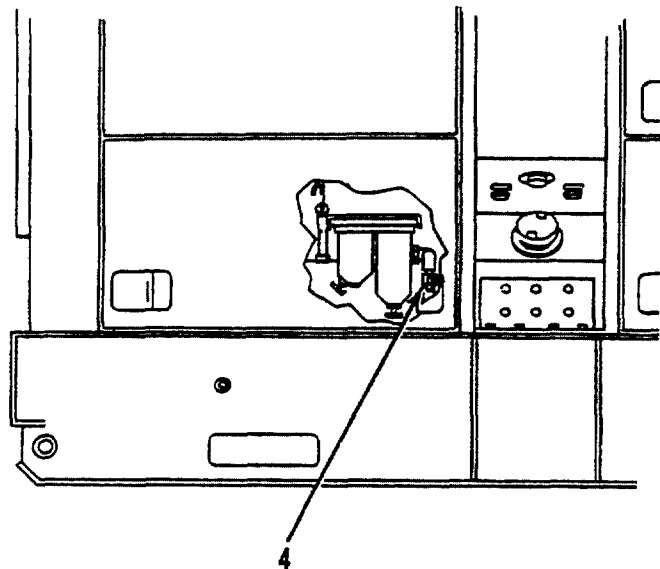
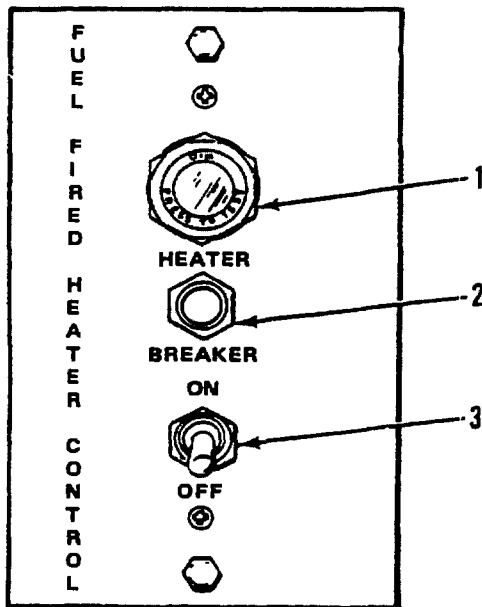

F9100672

Figure 2-11. Fuel Burning Winterization Kit, Controls and Indicators

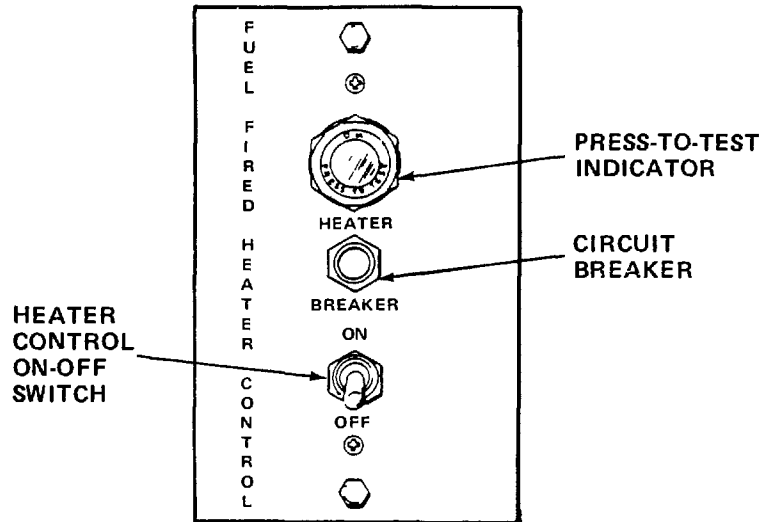

Table 2-4. Fuel Burning Winterization Kit,  
 Control and Indicators

FIGURE AND INDEX NO.	CONTROL OR INDICATOR	FUNCTION	NORMAL READING/SETTING
2-11, 1	Heater Control Indicator	When lit, indicates that fuel burning winterization kit is in the on cycle. When HEATER CONTROL ON-OFF switch is initially set to ON, indicator will light. This is a Press-to-Test lamp.	Lit
2-11, 2	Heater Control BREAKER switch	Controls application of 24 vdc to fuel burning winterization kit.	Depressed to on
2-11, 3	Heater Control ON-OFF switch	Turns fuel burning winterization kit on or off.	ON
2-11, 4	HEATER SHUT-OFF VALVE	Controls flow of fuel oil to fuel burning winterization kit.	ON

AIR FORCE	T.O. 35C2-3-442-11
ARMY	TM5-6115-600-12
NAVY	NAVFAC P-8-628-12
MARINE CORPS	TM-07464B-12

This page left intentionally blank



- STEP 1. DEPRESS AND RELEASE CIRCUIT BREAKER AND PRESS-TO-TEST INDICATOR. INDICATOR SHOULD LIGHT WHEN PRESSED AND GO OUT WHEN RELEASED.
- STEP 2. SET HEATER CONTROL ON-OFF SWITCH TO ON AND CHECK THAT THE PRESS-TO-TEST INDICATOR LIGHTS WHEN HEATER IGNITES.

NOTE

A LOW PITCHED SOUND MAY BE HEARD WHILE HEATER IS BEING PRIMED. IF PRESS-TO-TEST INDICATOR DOES NOT LIGHT IN APPROXIMATELY 3-1/2 MINUTES, SET HEATER CONTROL ON-OFF SWITCH TO OFF. WAIT 3 MINUTES AND SET HEATER CONTROL ON-OFF SWITCH TO ON. IF HEATER STILL DOES NOT START, AN EXTERNAL 24 V DC SOURCE MAY HAVE TO BE PROVIDED. (THE INTERNAL BATTERIES MAY NOT BE CAPABLE OF SUPPLYING SUFFICIENT CURRENT TO THE HEATER IGNITER).

- STEP 3. DO NOT ATTEMPT TO START ENGINE UNTIL FUEL BURNING HEATER IS CYCLING ON AND OFF AUTOMATICALLY. THE INDICATOR WILL GO ON AND OFF AS THE HEATER IS CYCLING. CYCLING SHOULD NOT OCCUR UNTIL THE HEATER HAS BEEN ON FOR APPROXIMATELY AN HOUR.

NOTE

THE HEATER WILL REMAIN IN STANDBY (CYCLING) FOR AS LONG AS THERE IS FUEL TO RUN IT.

- STEP 4. WHEN ENGINE HAS STARTED, SET HEATER CONTROL SWITCH TO OFF. INDICATOR SHOULD STAY LIT UNTIL HEATER FINISHES PURGE CYCLE (APPROXIMATELY 4-1/2 MINUTES). WHEN INDICATOR GOES OUT PULL CIRCUIT BREAKER TO OUT POSITION. THIS COMPLETELY SHUTS DOWN THE KIT.

Figure 2-12. Fuel Burning Winterization Kit, Operating Instructions

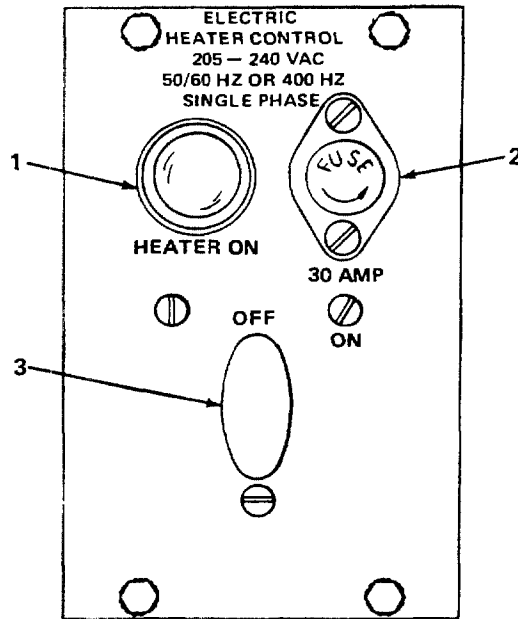
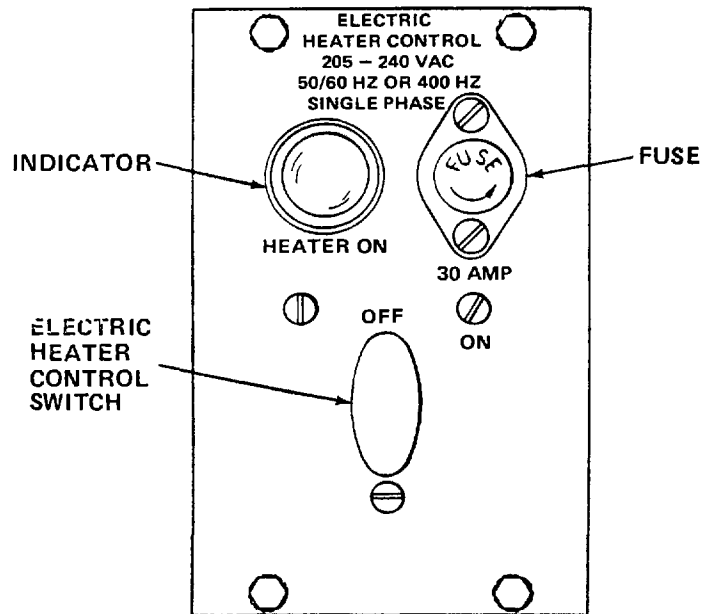

Figure 2-13. Electric Winterization Kit, Controls and Indicators

Table 2-5. Electric Winterization Kit, Controls and Indicators

FIGURE AND INDEX NO.	CONTROL OR INDICATOR	FUNCTION	NORMAL READING/SETTING
2-13, 1	HEATER ON Indicator	When lit, indicates that electric winterization kit is in the on-cycle. When ELECTRIC HEATER CONTROL ON-OFF switch is initially set to ON, indicator will light.	Lit
2-13, 2	ELECTRIC HEATER CONTROL FUSE 30 AMP	Protects electric winterization kit against circuit overload.	--
2-13, 3	ELECTRIC HEATER CONTROL ON-OFF switch	Controls application of power to electric winterization kit.	ON



- STEP 1. CONNECT POWER CABLE FROM ELECTRIC HEATER CONTROL BOX (J49) TO 220 V AC, 50/60 HERTZ SOURCE.
- STEP 2. SET ELECTRIC HEATER CONTROL SWITCH TO ON. INDICATOR SHOULD LIGHT.
- STEP 3. ALLOW FOR A MINIMUM OF 5 HOURS OR UNTIL HEATER IS CYCLING AUTOMATICALLY: INDICATOR WILL LIGHT ON AND OFF TO SHOW THAT CYCLING IS TAKING PLACE.
- STEP 4. THE ENGINE MAY BE STARTED ANYTIME AFTER HEATER BEGINS CYCLING.
- STEP 5. WHEN ENGINE HAS STARTED, SET ELECTRIC HEATER CONTROL SWITCH TO OFF. THIS COMPLETELY SHUTS DOWN THE KIT.

Figure 2-14. Electric Winterization Kit, Operating Instructions

### Section III. OPERATION UNDER UNUSUAL CONDITIONS

2-10. GENERAL. This section provides information on how to operate the generator set under unusual conditions. Unusual conditions are defined as extremes of the environment (such as very cold weather) or when the generator set contains faults (battle shorts) which will still allow continued although limited operation of the generator set.

2-11. OPERATION IN EXTREME COLD (BELOW -25°F, -31°C).

a. General. The generator set is designed to operate in temperatures of -25°F (-31°C) to 125°F (51°C) without external heat. Prior to starting the generator set in temperatures of -25°F (-31°C) to -65°F (-53.9°C) the winterization kits must be utilized as described in Section II of this chapter.

b. Fuel System. Keep fuel tanks as full as possible to prevent condensation of moisture. Use the proper grade of fuel oil for the existing outside temperature (refer to table 3-1). Wherever possible use a fresh supply of fuel (fuel that is not used for a long time tends to get gummy and produces contaminants that may be harmful to the engine). Drain water and sediment from fuel system more frequently than usual. Remove ice, snow, and moisture from area of fuel filler cap and filler neck.

c. Ether Starting. The most efficient and most reliable way of starting the diesel engine in extreme cold weather conditions is by injecting ether into the air intake system where it reduces the temperature at which the diesel fuel will ignite. To start the engine in cold weather, refer to figure 2-15.

#### CAUTION

If water is added to batteries in freezing temperatures, charge batteries or run engine for at least an hour to thoroughly mix water with battery acid.

d. Batteries. Clean batteries and cables. Remove cable clamps, one at a time, then use a knife to scrape away all corrosion from the inside surfaces of the clamp; bare, shiny metal should be exposed as a result. In a similar manner, also clean the battery terminal posts. Return clamps and tighten in place. Check that battery electrolyte level is at the level of filler slot in each cell, battery cap ventholes are open, and that battery terminals are lightly greased. Keep batteries fully charged. As the temperature drops so does the batteries' ability to crank the engine. If it is expected that the generator set is to be used in a few hours, disconnect the batteries and store them in a warm place until ready for use; then reconnect them.

e. Cooling System. Inspect level of coolant in radiator. Inspect cooling system for leaks, paying particular attention to gaskets and hose connection. Check that antifreeze solution is correct for lowest ambient temperature expected (refer to table 3-1).

2-12. OPERATION IN EXTREME HEAT.

a. Cooling System. Check coolant level of radiator daily and add clean fresh water as necessary. Check radiator to see that there are no obstructions in the cooling fins. Check for leaks and, if necessary, use an approved rust inhibitor (refer to

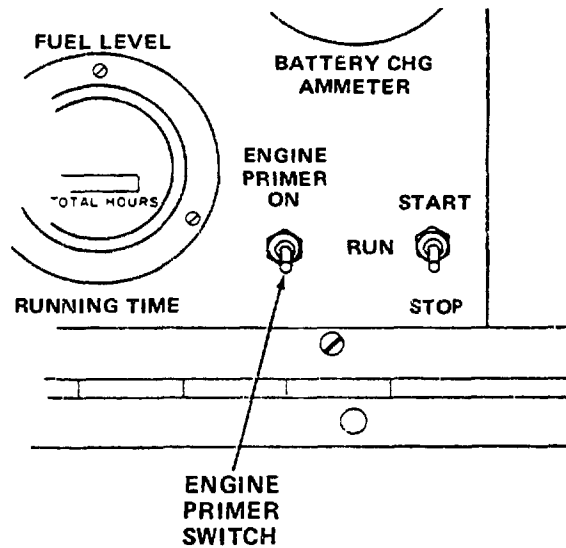

STEP 1. PREHEAT ENGINE AS DESCRIBED IN FIGURE 2-12 OR 2-14.

CAUTION

DO NOT INJECT ETHER INTO HOT ENGINE.

STEP 2. START ENGINE AS DESCRIBED IN FIGURE 2-5. SET (THEN RELEASE) ENGINE PRIMER SWITCH TO ON AS ENGINE IS BEING CRANKED. A METERED AMOUNT OF ETHER WILL BE INJECTED INTO ENGINE'S AIR INTAKE.

WARNING

ALLOW 3 MINUTES BEFORE ATTEMPTING TO CRANK ENGINE WHICH DOES NOT START.

STEP 3. IF ENGINE BEGINS TO START THEN FALTERS OR DOES NOT START AT ALL, OPERATE ENGINE PRIMER SWITCH AGAIN, WHILE CRANKING ENGINE.

NOTE

Generator sets are not to be transported by air or forwarded to a repair facility with compressed ether cylinder attached.

Figure 2-15. Ether Starting, Operating Instructions

table 3-1) to prevent formation of rust and scale. Make sure radiator shutter control valve is operating properly. Open all housing and radiator shutter doors prior to starting engine.

b. Lubrication. Lubricate engine using a proper grade of oil for the existing outside temperature (refer to figure 3-1).

c. Fuel System. Keep fuel tank full to prevent condensation but allow sufficient space for expansion of the fuel.

d. Batteries. Inspect the electrolyte level in the batteries daily. The electrolyte level should be up to the slots in the filler wells.

e. Generator. Keep the generator free of dirt and grime. Be sure that ventilating screens and louvers are free of obstructions which may restrict air flow.

f. Engine. After electrical load has been disconnected from generator output, permit engine to run at no load for at least 5 minutes to cool engine prior to shutdown.

#### 2-13. OPERATION IN DUSTY OR SANDY AREAS.

a. Protection. Keep all access doors and panels closed when generator set is not operating.

b. Cooling System. Inspect cooling system for leaks. Keep radiator cap on tight. Keep radiator cooling fins clean.

c. Lubrication. In dusty or sandy areas, lubricating oil filters must be serviced more frequently than under normal conditions. Clean all lubrication points before and after lubrication. Be sure that all lubrication containers are tightly sealed and stored in an area as free as possible from dust and sand.

d. Fuel System. Take all necessary precautions to keep dust, sand, and grit out of fuel tank. Service fuel filters and strainer more frequently than normally required.

e. Air Cleaner. Clean or replace air cleaner more frequently than normally required.

#### 2-14. OPERATION UNDER RAINY OR HUMID CONDITIONS.

a. Fuel System. Keep fuel tank full to prevent condensation of moisture. Drain water and sediment from fuel system components more frequently than usual.

#### WARNING

Corrosion prevention compound (MIL-C-16173) is flammable and slightly toxic. Avoid eye and skin contact or breathing of vapor. Eye, skin, and respiratory protection is required.

#### WARNING

Paint is flammable and moderately toxic to the skin, eyes, and respiratory tract. Skin, eye, and respiratory protection is required.

b. Rust Prevention. Clean generator set (refer to paragraph 3-18). Inspect painted surfaces for cracks, peeled, or blistered paint. Repair defects and repaint (olive drab, per MIL-T-704, Type A, semi-gloss No. X24087) surfaces.

#### 2-15. OPERATION IN SALT WATER AREAS.

a. Cleaning. Clean the generator set frequently (refer to paragraph 3-18).

#### WARNING

Corrosion prevention compound (MIL-C-16173) is flammable and slightly toxic. Avoid skin and eye contact or breathing of vapor. Skin, eye, and respiratory protection is required.

#### WARNING

Paint is flammable and moderately toxic to the skin, eyes, and respiratory tract. Skin, eye, and respiratory protection is required.

b. Protection. Keep all access doors and panels closed when generator set is not operating. Remove rust immediately and apply paint (olive drab, per MIL-T-704, Type A, semi-gloss, No. X24087) and/or rustproofing material as applicable.

#### 2-16. OPERATION IN SNOW.

a. Cooling System. Make sure radiator cooling fins and louvers are free of ice and snow before starting generator set.



WARNING

Corrosion prevention compound (MIL-C-16173) is flammable and slightly toxic. Avoid skin and eye contact or breathing of vapor. Skin, eye, and respiratory protection is required.

WARNING

Paint is flammable and moderately toxic to the skin, eyes, and respiratory tract. Skin, eye, and respiratory protection is required.

b. Protection. Keep all access doors and panels closed when generator set is not operating. Remove rust immediately and apply paint (olive drab, per MIL-T-704, Type A, semi-gloss, No. X24087) and/or rustproofing material as applicable. Remove snow from generator set before opening access panel and doors.

c. Before Starting. Remove snow from rear of generator set to prevent snow from being drawn into generator set.

2-17. OPERATION AT HIGH ALTITUDES.

a. General. The generator set is designed to operate at rated load at elevations up to and including 5,000 feet (1524 meters) above sea level, at 96.5 percent of rated load at 6,000 feet (1829 meters) and at 90 percent of rated load at 8,000 feet (2438 meters), without special adjustments.

b. Ventilation. Make sure there is adequate cooling air flow as the engine is more likely to overheat at high altitudes.

c. Cooling System. Inspect level of coolant in radiator and make sure that antifreeze solution is

correct for lowest ambient temperature expected (refer to table 3-1).

d. Fuel System. Keep fuel tank as full as possible to prevent condensation of moisture. Be sure to use proper grade of fuel for existing ambient temperature.

2-18. EMERGENCY (BATTLE SHORT) OPERATION.

a. General. Situations may arise where possible generator set damage is secondary in importance to its continued operation. Therefore, a means whereby certain fault conditions may be overridden is provided. In the event the generator set or the generator is shutdown or disconnected due to a fault, it is possible, in some cases, to operate the BATTLE SHORT switch (10, figure 2-2) on the control cubicle and enable the continued operation of the generator set. However, if shutdown is due to an overspeed or short circuit condition, the generator set fault circuits cannot be overridden and the set restarted. The generator set during an overspeed condition would destroy itself in short order. The generator, in the case of a short circuit, would burn out almost immediately.

b. Emergency Operation. To operate the generator set in the event of an emergency situation, refer to figure 2-16.

c. Emergency Shutdown. If, for any reason, setting the START-STOP-RUN switch to STOP fails to shutdown the engine, engine shutdown may be accomplished by deenergizing the DC control circuit breaker on the control panel. If this fails to stop engine, operate the manual shutdown lever, located on top of the governor (9, figure 4-62). Hold the lever in the forward position. Take the time to become familiar with this control.

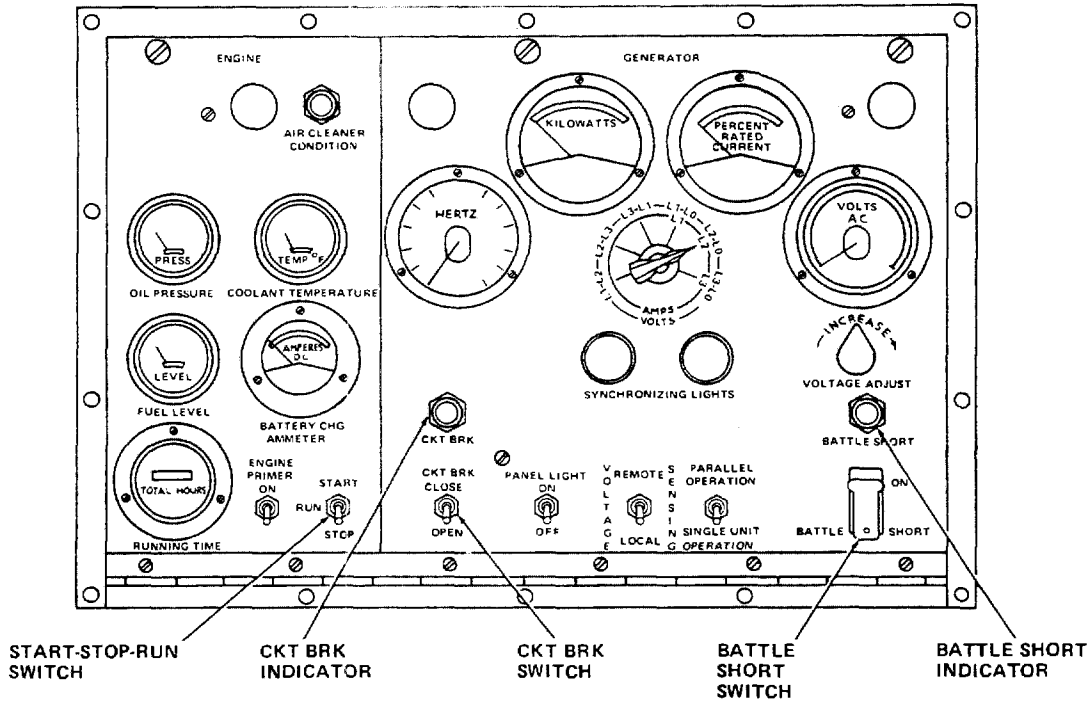

NOTE

AN ENGINE OVERSPEED OR A GENERATOR SHORT CIRCUIT CONDITION CAN NOT BE OVERRIDEN.

- STEP 1. TO RESTART GENERATOR SET AFTER A SHUTDOWN DUE TO A FAULT CONDITION, REFER TO FIGURE 2-5 TO START THE ENGINE.
- STEP 2. WITH START-STOP-RUN SWITCH AT START, SET BATTLE SHORT SWITCH (AFTER LIFTING RED PROTECTIVE GUARD) TO ON. BATTLE SHORT INDICATOR WILL LIGHT AND STAY LIT.
- STEP 3. AFTER ENGINE HAS RESTARTED, SET START-STOP-RUN SWITCH TO RUN.
- STEP 4. TO RECLOSE MAIN CIRCUIT BREAKER (OPENED DUE TO A FAULT), SET BATTLE SHORT SWITCH TO ON. BATTLE SHORT INDICATOR WILL LIGHT.
- STEP 5. SET CKT BRK SWITCH TO CLOSE. WHEN CKT BRK INDICATOR COMES ON, RELEASE CKT BRK SWITCH.

NOTE

AT FIRST OPPORTUNITY TO SHUT DOWN ENGINE, HAVE INDICATED FAULT CORRECTED.

Figure 2-16. Emergency Operation (Battle Short) of Generator Set

2-19. OPERATION USING NATO SLAVE CABLE.

a. Before using any cable, make sure the master battery switches and all electrical switches in both live and dead equipment are in the off position. If attempting to install the cable into live operating equipment, arcing can occur. Personnel burns and cable may be damaged.

b. The existing Army slave cable has end connectors with tow pins to mate with the slave receptacle (SR1 or SR2) on the generator set (refer to figure 1-1). The NATO slave cable has end connectors with one pin. In order to utilize the NATO slave cable on the generator set, an adapter connector must be used. See Additional Authorization List (AAL) for Adapter Connector.



## CHAPTER 3

### OPERATOR/CREW MAINTENANCE INSTRUCTIONS

#### Section I. CONSUMABLE OPERATING AND MAINTENANCE SUPPLIES

3-1. This section contains a listing of the consumable maintenance and operating supplies required to operate and maintain the generator set. This listing includes only items peculiar to and re-

quired for maintenance and operation of the generator set. Information is provided whereby the operator may correctly identify the item by its National Stock Number (NSN). Refer to table 3-1.

Table 3-1. Consumable Operating and Maintenance Supplies

COMPONENT APPLICATION	NATIONAL STOCK NUMBER	DESCRIPTION	QTY REQUIRED FOR INITIAL OPERATION	QTY REQUIRED 8 HOURS OPERATION	NOTES
Tank, Fuel		FUEL DIESEL			For temperatures:
		VV-F-800, Grade DF-2	92 gallons (348 liters)	72 gallons (273 liters)	+20°F to +125°F (-6.6°C to 51°C)
		VV-F-800, Grade DF-1			-25°F to +20°F (-31°C to -6.6°C)
		VV-F-800, Grade DF-A			-65°F to -25°F (-53.3°C to -31°C)
		JP-4			To be used as an emergency fuel only
		MIL-J-5624, JP-8			+100°F to -65°F (38°C to -54°C)
Crankcase		OIL, LUBRICATING 5-gallon pail as follows:	30 quarts (28.4 liters)	0.2 quarts (0.2 liters)	For temperatures:
		MIL-L-2104C OE/HDO 30	30 quarts (28.4 liters)	0.2 quarts (0.2 liters)	+20°F to +125°F (-6.6°C to 51°C)
		MIL-L-2104C OE/HDO-10	30 quarts (28.4 liters)	0.2 quarts (0.2 liters)	0°F to +20°F (-17.7°C to -6.6°C )
		MIL-L-46167 OEA	30 quarts (28.4 liters)	0.2 quarts (0.2 liters)	0°F to -65°F (-17.7°C to -53.3°C)
Radiator		Water			For Temperatures.
		W/O-1-490	11 gallons (42 liters)		+40°F to +125°F (+4.4°C to +51°C)
		Antifreeze MIL-A-46153	4.8 pints (2.3 liters) per gallon (3.785 liters) of solution		+40°F to -40°F (+4.4°C to -39.6°C)
		MIL-A-11755	11 gallons (42 liters)		-65°F to -45°F (-53.3°C to -42°C)

Table 3-1. Consumable Operating and Maintenance Supplies (Continued)

COMPONENT APPLICATION	NATIONAL STOCK NUMBER	DESCRIPTION	QTY REQUIRED FOR INITIAL OPERATION	QTY REQUIRED 8 HOURS OPERATION	NOTES
Radiator	0-I-490-6850-753-4967	Inhibiter, anti-rust	4.8 pints (2.3 liters) per gallon (3.785 liters) of solution		
Ethel Ether Starting System	2910-00-646-9727	Tank, ether	One tank	One tank	
Batteries	6810-00-249-9354	Electrolyte	14 quarts (13.3 liters)		
Parts, Cleaning	6950-00-281-1985(2)	Solvent (1 gallon, 3.8 liters) can, FED-P-D-680, MIL-C-87937, Type II, III and IV			

## Section II. LUBRICATION INSTRUCTIONS

3-2. **GENERAL.** This paragraph contains a reproduction of the lubrication order and lubrication instructions which are supplemental to, and not specifically covered in the lubrication order. The lubrication order shown in figure 3-1 is an exact reproduction of the approved lubrication order. Refer to Army LO 5-6115-600-12 and Marine Corps LI 07464B.

### 3-3. DETAILED LUBRICATION INFORMATION.

a. General. Keep all lubricants in closed containers and store in a clean, dry place away from external heat. Allow no dust, dirt, or other foreign material to mix with the lubricants. Keep all lubrication equipment clean and ready to use.

b. Cleaning. Keep all external parts not requiring lubrication clean of lubricants. Before lubricating the equipment, wipe all lubrication points free of dirt and grease. Clean all lubrication points after lubricating to prevent accumulation of foreign matter.

c. Points of Lubrication. Service the lubrication points at proper intervals as illustrated in figure 3-1.

#### d. Crankcase Oil.

(1) The crankcase oil level must be checked frequently, as oil consumption may increase.

(2) The oil may require changing more frequently than usual because contamination by dilution and sludge formation will increase under cold weather operation conditions.

e. Checking and Servicing Crankcase Oil Level. The engine dipstick (crankcase oil level gage) is the shielded type which allows checking oil level while the engine is either stopped or running. The dipstick is stamped on both sides to indicate the two different oil levels. The engine running side is stamped: ADD, FULL and RUNNING. The engine stopped side is stamped: ADD, FULL, and STOPPED. Check and service engine crankcase oil level as follows (refer to figure 3-1):

LUBRICATION ORDER

**LO 5-6115-600-12**  
**LI-07464B-12**

GENERATOR SET, DIESEL ENGINE DRIVEN, TACTICAL, SKID MTD., 100 KW,  
 3 PHASE, 4 WIRE, 120/208 AND 240/416 VOLTS

DDO MODEL	CLASS	HERTZ	NSN
MEP007B	UTILITY	50/60	6115-01-036-6374

Reference: C1900-IL

Intervals (on-condition or hard time) and the related task-hour times are based on normal operation. Change the hard time interval if your lubricants are contaminated or if you are operating the equipment under adverse operating conditions, including longer-than-usual operating hours. The hard time interval may be extended during periods of low activity. If extended, adequate preservation precautions must be taken.

On-condition (OC) intervals for oil changes shall be determined by the Army Oil Analysis Program (AOAP) laboratory and shall be applied unless otherwise notified.

Hard time oil change intervals will be applied in the event AOAP laboratory support is not available.

Clean fittings before lubricating. Clean parts with drycleaning SOLVENT (SD), type II or equivalent. Dry before lubricating.

The lowest level of maintenance authorized to lubricate a point is indicated by one of the following: (C) Operator/Crew; or (O) Organizational Maintenance.

Relubricate after washing or fording.

Drain crankcase when hot. Fill and check level.

The time specified is the time required to perform 11 services at the particular interval (On-condition or hard time).

You can help improve this lubrication order. If you find any mistakes or if you know of a way to improve the procedures, please let us know. Mail your letter or DA Form 2028 (Recommended Changes to Publications and Blank Forms) to: Commander, US Army Troop Support Command, ATTN: AMSTR-MCTS, 4300 Goodfellow Blvd, St. Louis, MO 63120-1798. A reply will be furnished to you.

LUBRICANT • INTERVAL

INTERVAL • LUBRICANT

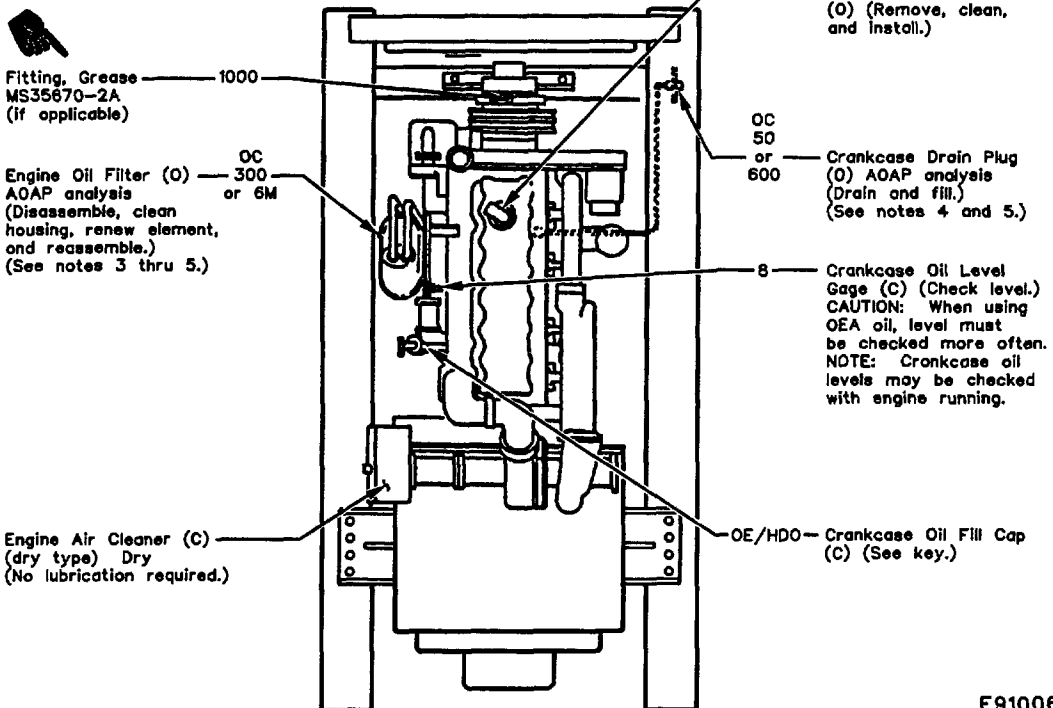

Figure 3-1. Lubrication Order (Sheet 1 of 2)

• TOTAL TASK-HR		• TOTAL TASK-HR	
INTERVAL	TASK-HR	INTERVAL	TASK-HR
8	0.1	60 or 600	0.6
100	0.4		

-KEY-

LUBRICANTS	CAPACITY	EXPECTED TEMPERATURES			INTERVALS
		ABOVE +32°F (ABOVE 0°C)	+40°F TO -10°F (+5°C TO -23°C)	0°F TO -65°F (-18°C TO -50°C)	
OE/HDO (MIL-L-21040) LUBRICATING OIL, Engine Engine Crankcase with Filters Oil Can Points	30 qts (28L)	OE/HDO 30	OE/HDO 10	OE/A	For artic operation refer to FM 9-207.  Intervals given are in hours of normal operation
OE/A (MIL-H-46167) LUBRICATING OIL, Engine, Subzero	30 qts (28L)				

NOTES:

- FOR OPERATION OF EQUIPMENT IN PROTRACTED COLD TEMPERATURES BELOW -10°F (-23°C). Remove lubricants prescribed in the key for temperatures above -10°F (-23°C). Clean parts with drycleaning SOLVENT (SD), type II or equivalent. Lubricate with lubricants specified in the key for temperatures 0°F to -65°F.
- OIL CAN POINTS. Every 100 hours lubricate hinges, latches, control linkages, and all exposed adjusting threads with OE-HDE.
- ENGINE OIL FILTER. Oil filter replacement interval shall align with on-condition ADAP analysis or hard time oil change requirements. See notes 4 and 5. After installing a new filter element, fill crankcase, operate engine for 5 minutes, and check for leaks. Shut engine down, check crankcase oil level, and bring to full mark.
- CRANKCASE OIL. A sample of the oil shall be sent to an ADAP laboratory for analysis at an interval of 50 hours or 60 days. Refer

to TB 43-0210 for sampling requirements.

5. When ADAP laboratory support is not available, drain and refill crankcase oil at 300 hours or 6 months.

Copy of this lubrication Order will remain with the equipment at all times; instructions contained herein are mandatory.

BY ORDER OF THE SECRETARIES OF THE ARMY AND NAVY

JOHN A. WICKHAM  
 General, United States Army  
 Chief of Staff

OFFICIAL:

MILDRED E. HEDBERG  
 Brigadier General, United States Army  
 The Adjutant General

F9100677

Figure 3-1. Lubrication Order (Sheet 2 of 2)



CAUTION

Use appropriate add and full marks depending upon whether engine is stopped or running. Also, ensure that the appropriate side is up when inserting the dipstick since the underside will be wiped in the gage tube when the dipstick is removed, therefore indicating a false oil level reading.

(1) Remove and wipe oil from dipstick (loosen and remove oil filler cap to allow pressure to escape).

(2) Check crankcase lubricating oil level using engine dipstick.

(3) Remove crankcase oil fill cap and add oil as required to obtain full level on dipstick. Refer to figure 3-1 for proper lubricating oil.

**Section III. PREVENTIVE MAINTENANCE CHECKS AND SERVICES (PMCS)**

3-4. GENERAL. To ensure that the engine generator set is ready for operation at all times, it must be inspected systematically so defects may be discovered and corrected before they result in serious damage or failure. Defects discovered during operation of the unit shall be noted for future correction, to be made as soon as operation has ceased. Stop operation immediately if a deficiency is noted during operation which would damage the equipment. All deficiencies and shortcomings shall be recorded together with the corrective action on the applicable form, at the earliest possible opportunity. The information contained in this section will help to keep the equipment in a safe operating condition.

a. Before operating, always keep in mind the CAUTIONS and WARNINGS performed "Before" (B) PMCS.

b. While operating, always keep in mind the CAUTIONS and WARNINGS. Performed "During" (D) PMCS.

c. After operation, be sure to perform "After" (A) PMCS.

d. If equipment fails to operate troubleshoot with proper equipment. Report any deficiencies using the proper forms. See DA Pam 738-750.

e. Leakage definitions for operator/ crew PMCS shall be classified as follows:

Class I Seepage of fluid (as indicated by wetness or discoloration) not great enough to form drops.

Class II Leakage of fluid great enough to form drops but not enough to cause drops to drip from the item being checked/inspected.

Class III Leakage of fluid great enough to form drops that fall from the item being checked/inspected.

3-5. PMCS PROCEDURE.

a. PMCS table lists the inspections and care of equipment required to keep it in good operating condition. Perform checks and services in the listed order.

b. The interval column of PMCS table tells when to do a certain check or service.



c. The procedures column of PMCS table tells how to do the required checks and services. Carefully follow the instructions.

d. If equipment does not perform as required, refer to troubleshooting procedures in Chapter 3 for possible fault isolation. Report malfunctions or failures on DA Form 2404 in accordance with DA Forms 738-750.

e. The last column tells the kinds of conditions that would cause equipment to be not ready or available for operation to perform its primary combat mission. An entry in this column denies use of the equipment until corrective

maintenance has been performed.

### 3-6. PREVENTIVE MAINTENANCE CHECKS AND SERVICES TABLE.

a. (A, N, MC). Table 3-2 contains a tabulated listing of preventive maintenance checks and services to be performed by the operator/crew. The item numbers are consecutively listed to allow performance checks and services with minimal time and movement.

b. Air Force users shall refer to the applicable inspection manuals and work card sets in TO 35C2-3 series for periodic requirements and Table 3-2 for detailed procedures.

Table 3-2. Operator Preventive Maintenance Checks and Services

INTERVAL			B - BEFORE OPERATION D - DURING OPERATION A - AFTER OPERATION DAILY - 8HRS	TOTAL T/H: 1.1
OPERATOR			ITEMS TO BE INSPECTED. INSPECTION PROCEDURES.	WORK TIME T/H
DAILY				
B	D	A		
1		14	GENERATOR SET Check ground cable. Ensure that set is free of tools, etc.	0.1
2	11	15	ENGINE Check for required lube oil level; add as required (refer to paragraph 3-3e).	0.1
3		16	Check engine for loose connections, free action of all moving parts (throttle linkage, emergency shutoff lever) and for leaking oil, fuel, or coolant.	0.1
4		17	COOLANT SYSTEM Check for hoses and hose clamp for security and required coolant level; add as required (refer to paragraph 3-14b).	0.1
5		18	BATTERIES Check batteries for required electrolyte level; add distilled or clean water as required (see paragraph 3-9a).	0.1
6		19	AIR INTAKE SYSTEM Check air intake system cleaner for excessive dirt; remove and clean air cleaner panels as required (see paragraph 3-16a).	0.1
7	10	20	EXHAUST EXTENSION (generator sets operating indoors)  Inspect exhaust extension for condition, tightness, and leakage at seams and point of coupling.	0.1
8		21	ALTERNATOR AND BELTS Inspect alternator for signs of overheating, frayed or loose wiring, and corrosion. Inspect alternator drive belts and fan belts for cracks, fraying, proper tension, and other signs of deterioration. Refer to figure 4-56).	0.1

Table 3-2. Operator Preventive Maintenance Checks and Services (Continued)

INTERVAL			B - BEFORE OPERATION D - DURING OPERATION A - AFTER OPERATION DAILY - 8HRS	TOTAL T/H: 1.1
OPERATOR			ITEMS TO BE INSPECTED. INSPECTION PROCEDURES.	WORK TIME T/H
DAILY				
B	D	A		
9		22	BREATHER Inspect breather extension for tightness, general condition, and leakage (refer to paragraph 3-13d). Check that breather coupling is not restricting air flow and that breather exit port is clear.	0.1
	12		FAULT INDICATOR PANEL Using TEST or RESET switch, check indicator lamps.	0.1
	13		CONTROL CUBICLE PANEL Check for proper indications as follows: BATTERY CHG AMMETER: Reading in green portion of scale. COOLANT TEMPERATURE gage: 180°F to 200°F (81.4°C to 92.4°C). OIL PRESSURE gage: 40 to 60 psig VOLTS AC meter: 120/208 to 240/416 volts AC (depending on AMPS-VOLTS select switch and position of voltage change board). PERCENT RATED CURRENT meter: 100 percent max. KILOWATTS meter: 100 percent max (60, Hz operation), 33.3 KW max (50, Hz operation). HERTZ (frequency) meter: 50 or 50 Hertz.	
		26	DAY TANK: Drain water and sediment (use a 5/8 inch coupling and a drain tube to run waste clear of generator set - see figure 4-46.	0.2
		27	FUEL FILTER AND STRAINER: Drain water and sediment (use rags to catch waste). Refer to paragraph 4-85.	0.1
		28	FUEL TANK AND AUXILIARY TANK: Check fuel level.	0.1

## Section IV. TROUBLESHOOTING

### 3-6. GENERAL.

a. Table 3-3 contains troubleshooting information for locating and correcting operating troubles which may develop in the generator set. Each malfunction for an individual component, unit, or system is followed by a list of tests or inspections which will help determine probable causes and corrective actions to take. You should perform the tests/inspections and corrective actions in the order listed.

b. This manual cannot list all malfunctions that may occur, nor all tests or inspections and corrective actions. If a malfunction is not listed or cannot be corrected by listed corrective actions, notify your supervisor.

#### NOTE

Before you use table 3-3, be sure you have performed all applicable operating checks.

Table 3-3. Troubleshooting, Operator

MALFUNCTION
TEST OR INSPECTION
CORRECTIVE ACTION

1. ENGINE FAILS TO CRANK OR CRANKS SLOWLY WHEN START-RUN-STOP SWITCH IS SET TO START (USUAL CONDITIONS).

Step 1. Check to see if electrolyte level in battery cells is at proper level.

If electrolyte level is below top of plates, add distilled or clean water until electrolyte level is three fourths of an inch above the separators. Recharge batteries (refer to next higher level of maintenance).

Step 2. Inspect for loose, corroded, or broken battery cables.

Disconnect battery cable clamps, negative cable first, and clean (using a wire brush) inside surface of clamps. Also, using a wire brush, clean mating surface of clamp. Tighten all loose connections at battery, ground, and starter assembly. If cables are broken, notify next higher level of maintenance.

Table 3-3. Troubleshooting, Operator (Continued)

MALFUNCTION	TEST OR INSPECTION	CORRECTIVE ACTION
	Step 3.	Inspect that two 12-volt batteries are connected in series and that battery polarity is correct.  The positive terminal of one battery should be connected to the negative terminal of the other battery. The positive terminal of each battery should be positioned toward the left side of its storage compartment.
	Step 4.	Using a hydrometer, check the specific gravity (an indication of the battery's condition) of each battery.  If the reading is less than 1.250, recharge batteries (refer to next higher level of maintenance).
	Step 5.	Remove and inspect battery cable lugs connected to the starter motor.  Clean and replace as required.
2.	ENGINE FAILS TO CRANK OR CRANKS SLOWLY WHEN START-RUN-STOP SWITCH IS SET TO START DURING COLD WEATHER CONDITIONS (BELOW -25°F OR -31°C) AND WITH WINTERIZATION KIT INSTALLED.	Note  Use slave receptacle (SR1 or SR2) when extra cranking power is required.
	Step 1.	Check COOLANT TEMPERATURE gage.  If low, but above ambient temperature, allow more time for winterization kit to preheat the engine.  If coolant temperature is about the same as ambient temperature (or COOLANT TEMPERATURE gage does not read at all), check that winterization kit has been properly turned on -- if it has, refer to the appropriate troubleshooting procedures in Chapter 5.
	Step 2.	Check that electrolyte level in battery cells is at proper level.  If electrolyte level is below top of plates, add distilled or clean water until electrolyte level is three fourths of an inch above the separators. Recharge batteries. Use slave receptacle (SR1 or SR2) when extra cranking power is required (refer to next higher level of maintenance).

Table 3-3. Troubleshooting, Operator (Continued)

MALFUNCTION	TEST OR INSPECTION	CORRECTIVE ACTION
	Step 3.	Inspect for loose, corroded, or broken battery cables.  Disconnect battery cable clamps, negative cable first, and clean (using a wire brush) inside surface of clamps. Also, using a wire brush, clean mating surfaces of clamp. Tighten all loose connections at battery, ground, and starter assembly. If cables are broken, notify next higher level of maintenance.
	Step 4.	Using a hydrometer, check the specific gravity (an indication of the battery's condition) of each battery.  If the reading is less than 1.250, recharge batteries (refer to next higher level of maintenance).
	Step 5.	Check that lubricating oil is correct grade for ambient temperatures.  Drain and refill with correct grade of lubricating oil (refer to figure 3-1).
	Step 6.	Remove and inspect battery cable lugs connected at starter motor.  Clean and replace as required.
3.	ENGINE CRANKS BUT FAILS TO START.	
	Step 1.	Check AIR CLEANER CONDITION indicator.  If lit, clean or replace air filter as required (refer to paragraph 3-16a).
	Step 2.	Inspect all fuel lines and fuel line fittings for leaks, loose connections or any signs of obvious damage.  Refer to next higher level of maintenance for replacement.
	Step 3.	Check NO FUEL indicator.  If lit, check both the set and day tanks (or auxiliary tank if used). Refill as required. If tanks contain adequate fuel, refer to next higher level of maintenance.



Table 3-3. Troubleshooting, Operator (Continued)

MALFUNCTION	TEST OR INSPECTION	CORRECTIVE ACTION
4. ENGINE SHUTS DOWN AND WILL NOT RESTART.		
	Step 1. Check indicators on FAULT INDICATOR panel.	
		If any one of them is lit, refer to steps 2 through 5 below, as applicable.
	Step 2. If COOLANT TEMPERATURE indicator is lit, check coolant level.	
		<p style="text-align: center;"><u>WARNING</u></p> Do not attempt to remove the radiator cap until the radiator has cooled to a point where there will be no built-up steam pressure. Failure to observe this warning could result in second or third degree burns.
		If low, add coolant (type should be as required by weather conditions, refer to table 3-1).
		If coolant level is normal, refer to next higher level of maintenance.
	Step 3. If LOW OIL PRESSURE indicator is lit, check lubricating oil level and type of oil being used.	
		If low, add lubricating oil as required (type should be as required by weather conditions). Refer to figure 3-1.
		If oil is of too light a grade, change to type as required by weather conditions. Refer to figure 3-1.
		If lubricating oil level is normal, refer to next higher level of maintenance.
	Step 4. CHECK NO FUEL indicator.	
		If lit, check both the set and day tanks (or auxiliary tank if used). Refill as required. If tanks contain adequate fuel, refer to next higher level of maintenance.
	Step 5. If OVERSPEED indicator is lit, refer to next higher level of maintenance.	

Table 3-3. Troubleshooting, Operator (Continued)

---

MALFUNCTION
TEST OR INSPECTION
CORRECTIVE ACTION

---

5. ENGINE RUNS ERRATICALLY OR MISFIRES.

Step 1. Check fuel for contamination.

If contaminated, drain fuel system and fill with proper fuel in accordance with table 3-1.

Step 2. Check air filter. Change or clean air filter as required.

6. ENGINE EXHAUST EXCESSIVELY BLACK.

Step 1. Inspect air filter for excessive dirt.

Change or clean air filter as required.

Step 2. Check KILOWATTS meter on control cubicle.

Reduce load to rated level. If KILOWATTS meter reading is within required value, refer to next higher level of maintenance.

7. ENGINE EXHAUST WHITE OR BLUE.

Step 1. Check for improper (too light a grade or diluted) lubricating oil.

Drain lubricating oil and fill with proper oil (refer to figure 3-1).

Step 2. Check for excessive lubricating oil using dipstick gage.

If crankcase is overfilled, drain until proper level is attained.

8. GENERATOR OUTPUT FREQUENCY INCORRECT.

Check HERTZ (frequency) meter on control cubicle.

If incorrect, adjust engine manual speed control to either increase or decrease as required to return CYCLES meter to correct frequency. If adjustment cannot be made refer to next higher level of maintenance.

Table 3-3. Troubleshooting, Operator (Continued)

MALFUNCTION	TEST OR INSPECTION	CORRECTIVE ACTION
9. GENERATOR OUTPUT VOLTAGE INCORRECT.		<p>Check VOLTS AC meter on control cubicle.</p> <p>If incorrect, set VOLTAGE ADJUST control to either increase or decrease voltage output as required to return VOLTS AC meter reading to correct voltage. If adjustment cannot be made refer to next higher level of maintenance.</p>
10. CKT BRK CLOSE INDICATOR DOES NOT LIGHT OR LIGHTS BUT DOES NOT STAY LIT.		<p>Step 1. Check indicators on FAULT INDICATOR panel and CKT BRK CLOSE indicator (press-to-test) on control panel.</p> <p>If any of them is lit, refer to appropriate subsequent step.</p> <p>Step 2. If SHORT CIRCUIT indicator is lit, have appropriate maintenance personnel check load circuit.</p> <p>When short circuit in load has been cleared, set TEST OR RESET switch to up position and then set CKT BRK switch up until CKT BRK CLOSE indicator lights.</p> <p>Step 3. If REVERSE POWER indicator is lit, check that paralleling setup procedures have been performed correctly (refer to paragraph 2-5).</p> <p>When paralleling procedures have been properly performed, set TEST OR RESET switch to up position and then set CKT BRK switch to up until CKT BRK CLOSE indicator lights.</p> <p>Step 4. If OVERLOAD indicator is lit, have appropriate maintenance personnel check that loading of generator has been balanced properly.</p> <p>When load circuits have been properly distributed, set TEST OR RESET switch to up position and then set CKT BRK switch to up until CKT BRK CLOSE indicator lights.</p> <p>Step 5. If OVER VOLT indicator is lit, check that VOLTAGE ADJUST control is set for proper voltage.</p> <p>When output voltage is set at required value, set TEST OR RESET switch to up position and then set CKT BRK switch to up until CKT BRK CLOSE indicator lights.</p> <p>If voltage cannot be properly adjusted, refer to next higher level of maintenance.</p>

Table 3-3. Troubleshooting, Operator (Continued)

---

MALFUNCTION
TEST OR INSPECTION
CORRECTIVE ACTION

---

11. HIGH COOLANT TEMPERATURE.

WARNING

Do not attempt to remove the radiator cap until the radiator has cooled to a point where there will be no built-up steam pressure. Failure to observe this warning could result in second or third degree burns.

Check radiator coolant level.

If low, add coolant (refer to table 3-1).

If coolant level is normal, refer malfunction to next higher level of maintenance.

12. LOW OIL PRESSURE.

Check lubrication oil level and type of oil being used.

If low, add oil (refer to figure 3-1).

If oil is too light a grade, change to type as required by weather conditions (refer to figure 3-1).

If lubricating oil level is normal, refer malfunction to next higher level of maintenance.

13. INDICATION ON KILOWATTS METER OR PERCENT RATED CURRENT METER EXCEEDS RATED VALUE.

Check load distribution.

Reduce load as required to return kilowatts indication on KILOWATTS meter to rated value.

14. ONE OR BOTH SYNCHRONIZATION FAIL TO LIGHT.

Check lamps.

---

## Section V. OPERATOR/CREW MAINTENANCE INSTRUCTIONS

3-7. GENERAL. Instructions in this section are provided to assist the operator in maintaining the generator set. If during inspections, defective components are noted, refer to the next higher level of maintenance for repair or replacement.

### 3-8. HOUSING.

a. Inspect access doors for rust, cracked paint, and freedom of motion. Inspect seals for deterioration.

b. Inspect that tool box moves freely and contains required complement of tools.

c. Check the air intake louvers and radiator grille for freedom of motion and ensure that they are not clogged.

d. Check all surfaces (panels and covers) for rust, corrosion, and cracked or chipped paint.

e. Check all hinges and latches for security of attachment.

f. Check all identification plates for corrosion, legibility, and security of attachment (see figure 1-3).

g. Refer to paragraph 3-18 for cleaning instructions.

### 3-9. DC ELECTRICAL AND CONTROL SYSTEM.

#### a. Batteries and Battery Cables

##### WARNING

Battery electrolyte contains sulfuric acid and can cause severe burns. It is highly toxic to the skin, eyes, and respiratory tract. Skin, eyes,

and respiratory protection is required. If electrolyte comes into contact with body, eyes, or clothing, rinse immediately with clean water. Do not smoke when servicing batteries.

(1) Refer to figure 3-2 to service the batteries.

(2) Using hydrometer, check condition of battery. A fully charged battery should have a specific gravity of 1.280 +/-0.005. If specific gravity is less than 1.250, battery should be recharged.

(3) Remove and inspect battery cables, one at a time, for corrosion, frayed wires, and cracked clamps. If mating surfaces of cables and terminals are corroded, clean as required to produce bare metallic surfaces.

##### NOTE

If these surfaces are not free of corrosion, the cranking ability of the batteries will be sharply impaired.

(4) Apply a light coating of corrosion resisting grease, then reconnect battery cables. Tighten cable clamps and terminals.

b. Slave Receptacles. Inspect slave receptacles (14, figure 2-1) for burnt, bent, or broken pins. Look for foreign matter in receptacle.

c. Battery Charging Alternator and Belt.

(1) Inspect alternator (see figure 4-16) for cracks, frayed or broken wires, and other signs of obvious damage.

(2) Inspect alternator drive belt for cracks, cuts, and looseness.

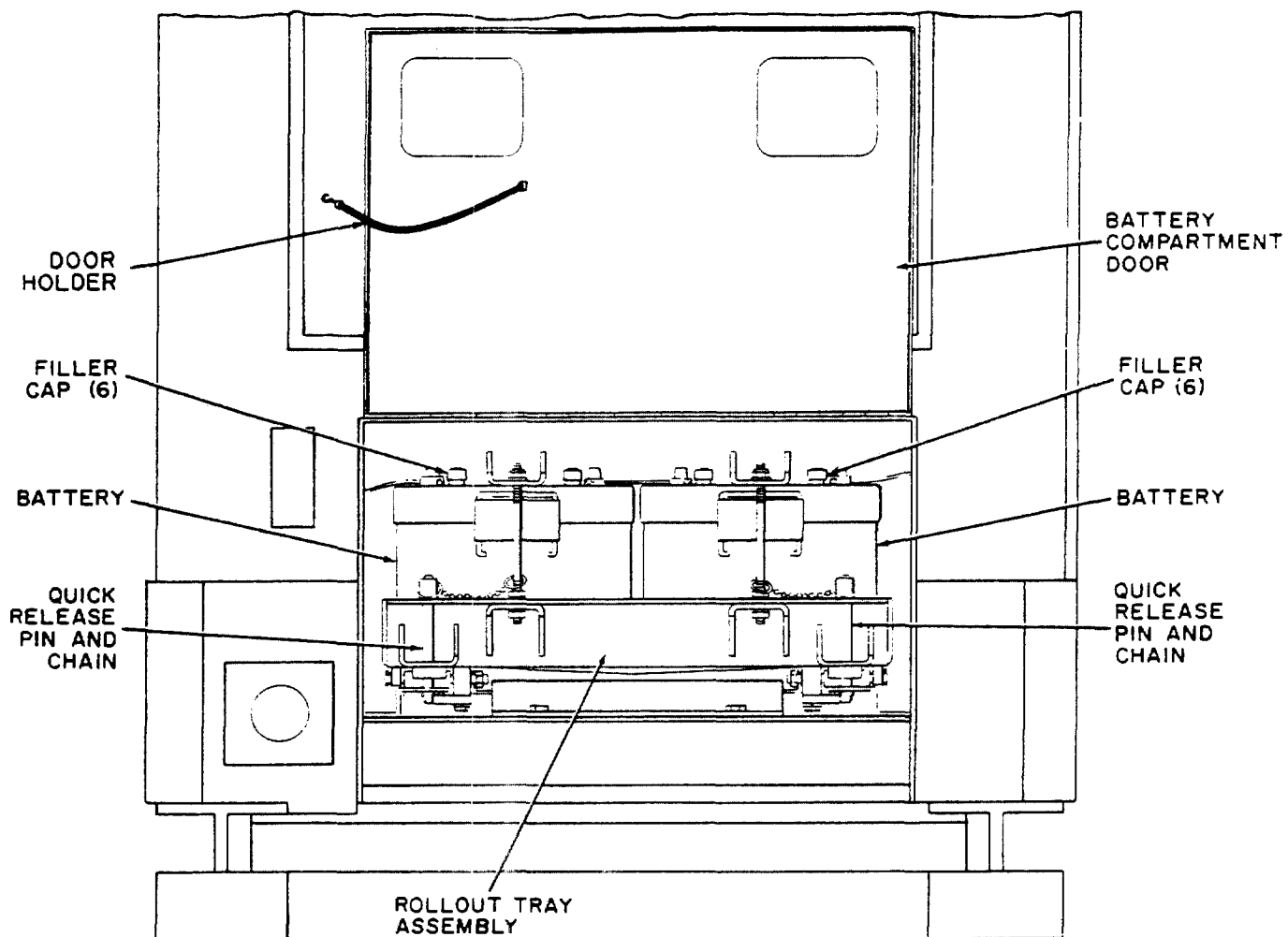

- STEP 1. OPEN BATTERY COMPARTMENT DOOR AND SECURE DOOR TO RADIATOR GRILLE WITH DOOR HOLDER.
- STEP 2. DEPRESS BUTTON ON QUICK RELEASE PINS, LIFT UP PINS, AND PULL ROLLOUT TRAY ASSEMBLY OUT.
- STEP 3. REMOVE FILLER CAP AND ADD DISTILLED WATER (TAP WATER IF DISTILLED WATER IS NOT AVAILABLE), AS REQUIRED TO BRING ELECTROLYTE LEVEL TO SLOT IN FILLER WELLS. CLEAN VENT HOLES IN FILLER CAP AND INSTALL CAPS.
- STEP 4. PUSH IN ROLLOUT TRAY ASSEMBLY AND INSTALL QUICK RELEASE PINS.
- STEP 5. CLOSE AND LATCH BATTERY COMPARTMENT DOOR.
- STEP 6. IF TEMPERATURE IS 32°F (0°C) OR BELOW, OPERATE GENERATOR SET FOR A MINIMUM OF 30 MINUTES TO CHARGE BATTERIES.

Figure 3-2. Batteries, Servicing

(3) Apply a 25 pound (10 kg) force (approximately) perpendicular to the alternator pulley, midway between the driver and a driven pulley. Belt deflection should be between 9/16 inch and 13/16 inch (15 and 20 mm).

d. Speed Switch and Magnetic Pick-up. Check speed switch and magnetic pick-up for signs of overheating, and shorted broken, or frayed wires.

e. Starter Assembly.

(1) Remove cables (one at a time) connected to starter assembly (see figure 4-14). Inspect cables for corrosion, frayed wires, cracked terminals. If mating surfaces of terminal lugs and terminals are corroded, clean as required to produce bare metallic surfaces.

#### NOTE

If these surfaces are not free of corrosion, the cranking ability of the starter motor will be sharply impaired.

(2) Check surfaces of starter motor for signs of overheating, such as corrosion and peeling paint.

#### 3-10. SET CONTROLS AND INSTRUMENTATION.

a. Meters and Gages. Inspect meters and gages (see figure 2-2) for bent pointers, broken glass, unreadable dial faces, and restricted movement of pointers. Clean gage and meter faces using a lint-free cloth.

b. Panel and Indicator Lights. Check for broken indicator lenses, and for unreadable lettering. Set PANEL LIGHT switch (14, figure 2-2) to ON; panel lights should light.

c. Switches. Check all switches for positive action; each switch should snap from one position to the next.

d. Engine Manual Speed Control. Inspect control (6, figure 2-1) for freedom of motion from one end of

controls range to the other.

e. Door Holder. Check that door holder secures doors in open and closed position.

3-11. AC ELECTRICAL CONTROL SYSTEM. Inspect convenience receptacles (10, figure 2-1) for burnt or cracked bakelite or other signs of obvious damage.

#### 3-12. FUEL SYSTEM.

a. Fuel Transfer Pumps (Electric). Inspect electric fuel transfer pumps (see figure 4-43) for secureness, tight fittings, signs of damage, corrosion, leaks, and loose electrical connectors.

b. Fuel Filters and Strainers. Inspect fuel filters and strainers (see figure 4-44 and 4-45) for leaks and tight fittings.

c. Day Tank.

(1) Inspect day tank (see figure 4-46) for leakage or signs of obvious damage.

(2) Remove cap from day tank drain valve and open valve. (Day tank is located inside housing structure just above fuel tank filler cap and strainer.)

(3) Drain water and sediment into suitable container and close valve. Install cap on valve.

d. Fuel Lines, Valves, and Fittings. Inspect fuel lines, valves, and fittings for bent, leaky, or loose connections and signs of obvious damage.

e. Fuel Tank. Inspect fuel tank for leakage or signs of obvious damage. Refer to figure 3-3 and service fuel tank as follows:

#### WARNING

Always maintain constant metal-to-metal contact between fuel tank filler neck and spout of fuel supply. This will prevent the possibility of sparking caused by static electricity.

AR-MCSM 960005-1

**DOUGLAS KIT**  
ARM PULLER

Material 4130 Steel

**PART I**

Fig. 3-2A (1 of 2)

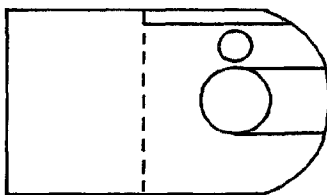
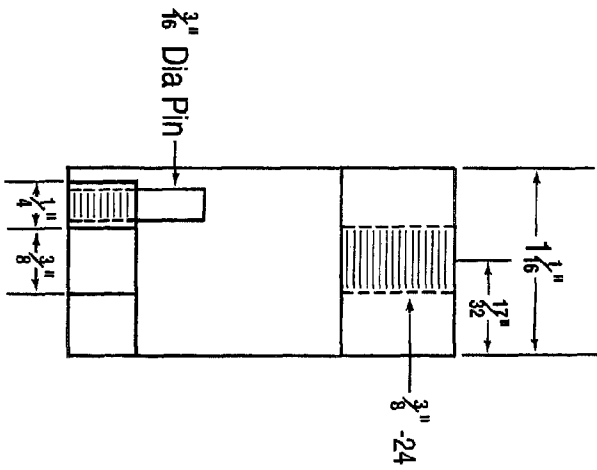
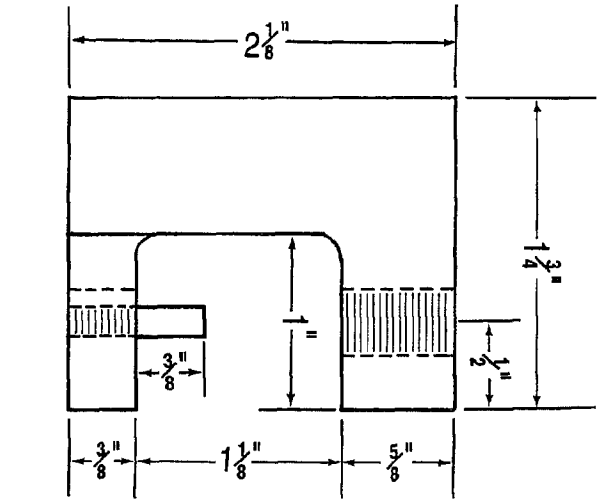
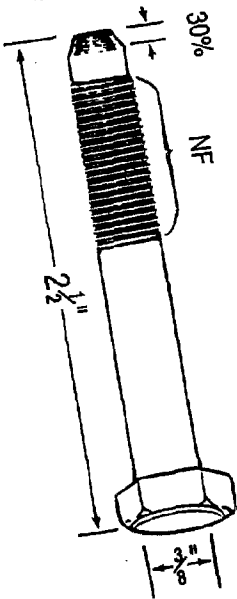
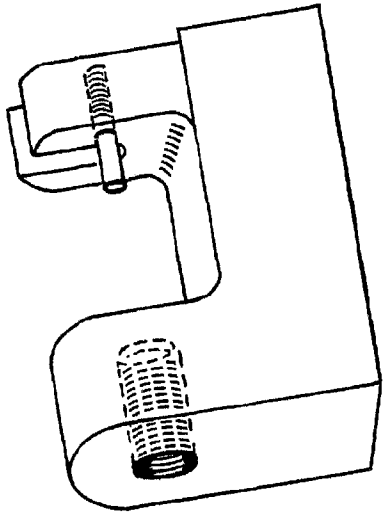



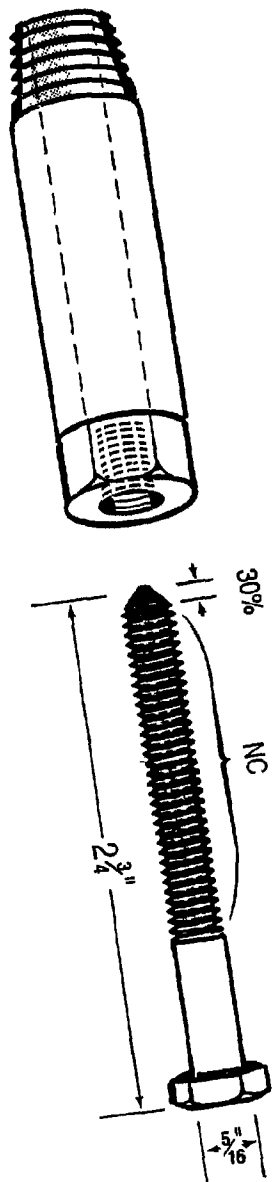
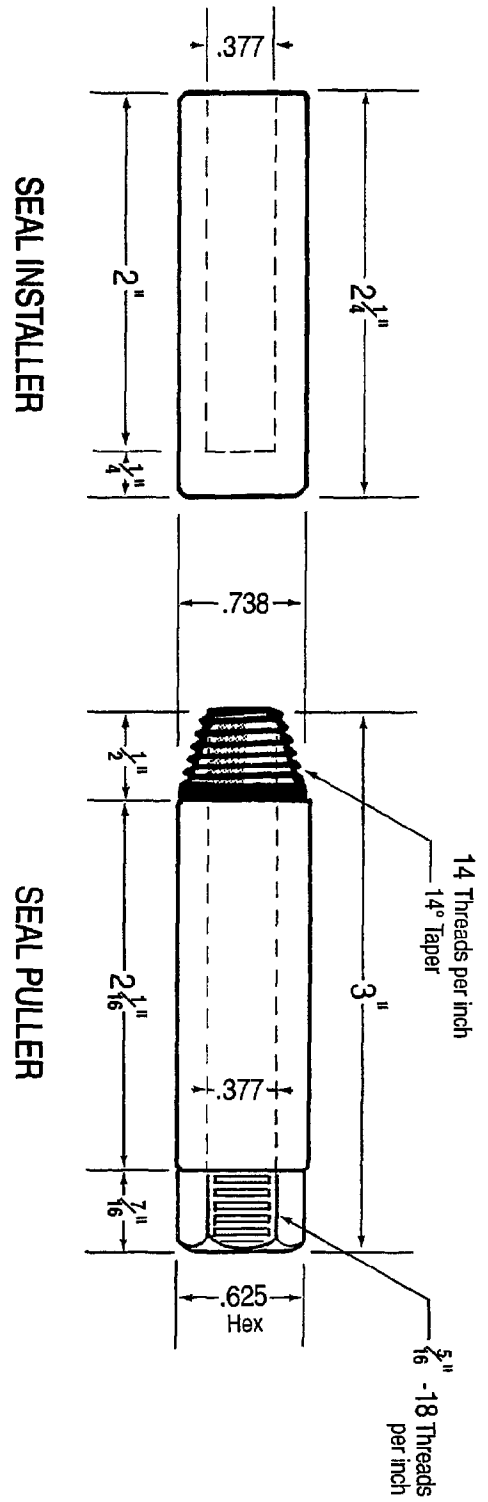
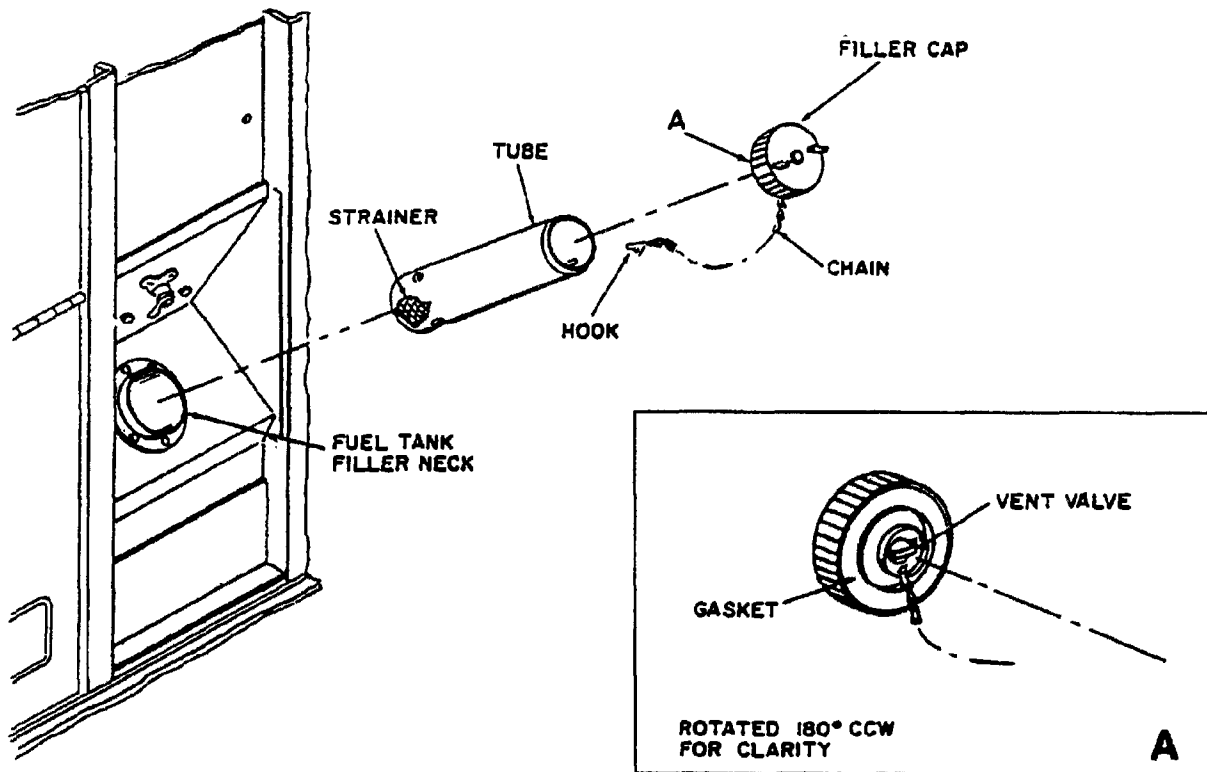

Fig. 3-2A (2 of 2)

AR-MCSM 960005-2

**DOUGLAS KIT**  
**SEAL INSTALLER AND PULLER**

**PART II**



F9800948

Figure 3-3. Fuel Filler Cap and Strainer

(1) Remove fuel tank filler cap (located at center of generator set left side) and fill fuel tank with proper fuel (refer to table 3-1).

(2) Replace filler cap and wipe up any spilled fuel.

f. Governor Drive. Inspect seal for leakage at Fuel Injection Pump Lever. If found defective repair as follow by using tooling numbers AR-MCSM 960005-1/-2 (See Figure 3-2A Sheets 1 and 2):

(1) Disconnect linkage rod from governor drive lever.

(2) Scribe a line between the shaft and lever to identify where the lever should be aligned with the shaft, when installed.

(3) Secure removal tool to lever over shaft.

(4) Turn bolt on removal tool until lever releases from shaft.

(5) Place seal removal tool over shaft and begin turning clockwise to imbed into the seal

case. Then turn bolt on tool until seal releases from drive housing.

**CAUTION**

Some fuel may spill after removal of seal.

(6) Clean off shaft and seal port of any FOD or contaminated fluids.

(7) Apply a light coat of oil on shaft and seal port, prior to installing new seal. Insert new seal and use setting tool over shaft and lightly tap on tool by using a mallet hammer until seal is properly seated.

(8) Align lever with shaft by mating scribe lines of both the lever and shaft. Tap lever by using a flathead soft drift with the outer diameter size to be the same size of the lever.

(9) Reconnect linkage rod.

(10) Start engine and after warm-up period, turn-off and inspect for leakage.

g. Fuel Tank (Sediment Drain).

(1) Remove cap from fuel tank drain valve and open valve. Permit water and sediment to drain into an approved nonflammable container.

(2) Close drain valve when clean fuel runs out of tank. Install cap on valve.

h. Ether System. Inspect ether system (see figure 4-47) for broken wires, loose connectors, corrosion, and any other signs of obvious damage.

i. Fuel Filler Cap and Strainer

(1) Remove filler cap and strainer as illustrated in figure 3-3.

to skin, eyes and respiratory tract. Eye and skin protection required. Good general ventilation is normally adequate.

(2) Clean parts with cleaning solvent, P-D 680, Type II, and dry thoroughly.

(3) Check filler cap vent valve for proper opening and closing.

(4) Inspect strainer for holes, breaks, and tears.

(5) Inspect parts for cracks, breaks, and other damage.

(6) Install filler cap and strainer as illustrated in figure 3-3.

**WARNING**

Solvent, Dry cleaning P-D-680, Type II is flammable and moderately toxic



**NOTE**

Fuel tank filler cap vent valve must be in open position during operation of generator set.

**3-13. EXHAUST AND BREATHER SYSTEM.**

a. Muffler and Clamps. Inspect muffler (see figure 4-50) for holes, dents, signs of extreme corrosion, and metal deterioration. Also check for loose or broken clamps and general secureness of muffler.

b. Exhaust Pipe and Ducts. Check all pipes and ducts associated with the exhaust system for holes, dents, signs of extreme corrosion and metallic deterioration. Also check for loose and broken bolts.

c. Exhaust Cap. Check exhaust cap (rain) for signs of corrosion and freedom of movement.

d. Breather Tube and Hoses. Check breather tube and associated hoses for loose clamps, holes in hoses, and loose bolts.

**3-14. COOLING SYSTEM.**

a. General. Check all hoses for cracks, cuts, signs of deterioration, and bulges (indicating the possibility of future rupture). Check all clamps for tightness and signs of corrosion. Inspect fan guard for loose sections and for overall secureness. Check radiator fan belt for proper tension as follows: apply a 25 pound (10 kg) force (approximately) perpendicular to the alternator pulley, midway between the drive and driven pulley; belt deflection should be between 9/16 inch and 13/16 inch (15 and 20 mm).

b. Radiator Coolant (Check and Service).

(1) Check that level of coolant is within 2 inches (51 mm) of top of radiator.

**WARNING**

Do not attempt to remove the radiator cap until the radiator has cooled to a point where there will be no built-up steam pressure. Failure to observe this warning could result in second or third degree burns.

(2) Using an antifreeze solution tester, check that antifreeze content is sufficient for the existing ambient temperature (refer to table 3-1). Add antifreeze as required.

(3) Fasten tag near radiator cap indicating type of coolant and level or protection.

c. Radiator (Drain, Flush and Refill).

(1) Place container at coolant drain (see figure 4-2).

(2) Open engine coolant drain valve and loosen radiator cap.

(3) Close drain valve.

(4) Fill coolant system with demineralized water.

**CAUTION**

Insure water pump is primed.

(5) Operate engine for 15 minutes.

(6) Drain water.

**CAUTION**

Use only ethylene glycol antifreeze.

(7) Refill coolant system with 50% antifreeze and 50% demineralized water. Higher ratios of ethylene glycol may be required due to extreme temperatures.

**3-15 LIFTING AND SUPPORT SYSTEM.** Inspect lifting frame (see figure 4-57) and support system for signs of corrosion, peeling, or cracked paint. Check that lifting eyes are secure and that they show no signs of weakness.

**3-16 ENGINE.**

a. Cleaning of Air Cleaners.

**CAUTION**

Do not start engine with air cleaners not in place.

(1) To remove air cleaners for inspection and/or cleaning, remove vertical retainer bar that holds air cleaner in place.

WARNING

Compressed air used for cleaning or drying can create airborne particles that may enter the eyes. Pressure shall not exceed 30 psig (206 kPa). Wearing of goggles is required.

(2) Remove and inspect air cleaners for dirt and clogging. The air cleaners shall be cleaned when AIR CLEANER CONDITION on control cubicle illuminates. Do not use gasoline or other petroleum solvents to clean panel filters. Panel filters shall be cleaned by one of three methods: washing with mild detergent and water solution, blowing with compressed air, or washing with water alone.

(3) Remove loose contaminants by blowing with compressed air or running water (40 psig, 276 kPa or less) through panel filter in reverse air flow direction. Keep air or water nozzles at least 1 inch (25.4 mm) from filters.

(4) Mix a solution of 5 gallons (19 liters) of water to 1 cup of mild detergent and place solution in a container.

(5) Place panel filter in container and soak for approximately 15 minutes. Swish filter in solution periodically.

(6) Remove panel filters from solution and rinse filters with gentle stream of water (40 psig, 276 kPa or less) in reverse air flow direction. Rinse until water passing through filter is clear.

(7) Permit panel filter to air-dry, or dry filter using dryer providing a maximum of 180°F (81°C) temperature with continuous air circulation.

WARNING

Compressed air used for cleaning or drying can create airborne particles that may enter the eyes. Pressure shall not exceed 30 psig (206 kPa). Wearing of goggles is required.

NOTE

Clean panel filters with compressed air when filters are contaminated with dust. To accomplish this, perform steps (8) and (9).

(8) Direct jet of compressed air against panel filter in reverse air flow direction. Keep air nozzle at least 1 inch (25.4 mm) away from filter.

(9) Move jet of compressed air over entire area of panel filter until all dust is removed.

NOTE

Wash panel filters with water alone when filters are contaminated with dust and compressed air not available. To accomplish this, perform steps (10) through (12).

(10) Direct gentle stream of water (40 psig, 276 kPa or less) through panel filter in reverse air flow direction.

(11) Direct water through panel filter until water passing through filter is clear.

(12) Permit panel filter to air-dry or dry filter using dryer providing a maximum of 180°F (81°C) temperature with continuous air circulation.

b. Inspection of Air Cleaners.

(1) Position a bright light on one side of panel filter.

NOTE

If there is a dent in protective screen, check filter carefully in area of dent.

(2) Look through panel filter toward light and inspect for holes and tears.

(3) Inspect gasket for damage. Gasket should be smooth, flat, and straight.

(4) Replace panel filters that have holes, tears, or defective gaskets.

c. Governor Throttle Linkage. Operate manual engine speed control and check governor throttle linkage for freedom of motion. Make certain that all parts are securely in place.

d. Fan Assembly. Inspect fan assembly for bent or broken fans, and for torn, cracked, or shredded fan belts.

e. Oil Filter. Inspect oil filter for leaks, loose case assembly, and other signs of obvious damage.

f. Oil Pan. Inspect that there are no oil leaks around the edges of the oil pan.

3-17. SUPPORT SYSTEM. Inspect the skid base for signs of corrosion, chipped or peeling paint, and loose attaching hardware.

3-18. GENERAL CLEANING. To prevent buildup of contaminants which may cause damage to operating components or systems of the generator set, the generator set should be cleaned periodically. Cleaning operations shall only be performed on generator sets that are not operating, connected to a parallel bus or connected in standby mode. To clean generator set, proceed as follows:

WARNING

Compressed air used for cleaning can create airborne particles that may enter the eyes. Pressure shall not exceed 30 psig (206 kPa). Wearing of goggles is required.

CAUTION

Exercise care to prevent dry cleaning solvent from coming in contact with electrical components.

a. Clean radiator cooling fins and vane bushings with compressed air.

WARNING

Dry cleaning solvent, P-D-680, Type II, is flammable and moderately toxic to the skin, eyes, and respiratory protection is required.

b. Painted metal surfaces should be wiped with a clean lint-free cloth moistened with cleaning solvent, (P-D-680, Type II). Hard deposits may be scrubbed off with a bristle brush that has been dipped in solvent. Dry surfaces with a clean lint-free cloth.

WARNING

Solvent, Dry Cleaning P-D-680, Type II is flammable and moderately toxic to skin, eyes and respiratory tract. Eye and skin protection required. Good general ventilation is normally adequate.

c. Clean linkages and control rods with cleaning solvent, P-D-680, Type II, and dry with a clean lint-free cloth.

d. Remove any dust, dirt, or sand from inside of generator set using a damp lint-free cloth.

e. Disconnect battery cables (negative first) and remove corrosion from battery terminals, cables, and holdown frames using a wire brush.

f. Clean battery filler cap vent holes.

g. Clean instrument faces using a clean lint-free cloth.





## CHAPTER 4

### ORGANIZATIONAL MAINTENANCE

#### Section I. SERVICE UPON RECEIPT OF EQUIPMENT

4-1. GENERAL. This section provides information necessary for organizational maintenance personnel to transport the generator set to where it will be used, to unpack and inspect it, to service it, and then check its operation before actually connecting it to the required load circuits.

#### 4-2. UNLOADING THE GENERATOR SET.

##### WARNING

Do not use a lifting device with a capacity of less than 10,000 pounds (4500 kg). Do not allow the generator set to swing while it is suspended. Failure to observe this warning may result in serious injury or death to personnel.

A crane, forklift, or similar lifting device or fabricated skids must be used to unload the generator set. The set must be kept in the UP position while unloading.

#### 4-3. UNPACKING THE GENERATOR SET.

a. Before unpacking, move the generator set as near as possible to the location where it will be operated.

##### CAUTION

Exercise care in the use of bars, hammers, and similar tools while uncrating the unit to avoid damaging the generator set.

b. Remove the top, the sides, and finally the ends of the packing crate (see figure 4-1).

c. If generator set is to be installed permanently, either inside or outside, remove wood skid base (the wood skid base is attached to the generator set by four carriage bolts and associated hardware).

d. If temporary installation is anticipated, do not remove the wood skid base. The wood skid base will establish a firm foundation on soft ground, mud, or snow.

#### 4-4. INSPECTING AND SERVICING THE GENERATOR SET.

a. Preparation. Prepare the generator set for inspection and operation as outlined in the following paragraphs. Refer to DA Form 2258, Depreservation Guide for Vehicles and Equipment (located in document compartment).

b. General Inspection. Open all access doors and make a thorough visual inspection of the generator set for loose or missing mounting hardware and damaged or missing parts. Report all damage or missing parts on DD Form 6. Check the fault indicator panel and control cubicle for broken or missing bulbs and fuses. Refer to Appendix B and check that all basic issue items are present and properly stored.

c. General Servicing. Remove coolant drain plug on skid base, make certain all drain cocks are closed, and other drain plugs are tight (see figure 4-2).

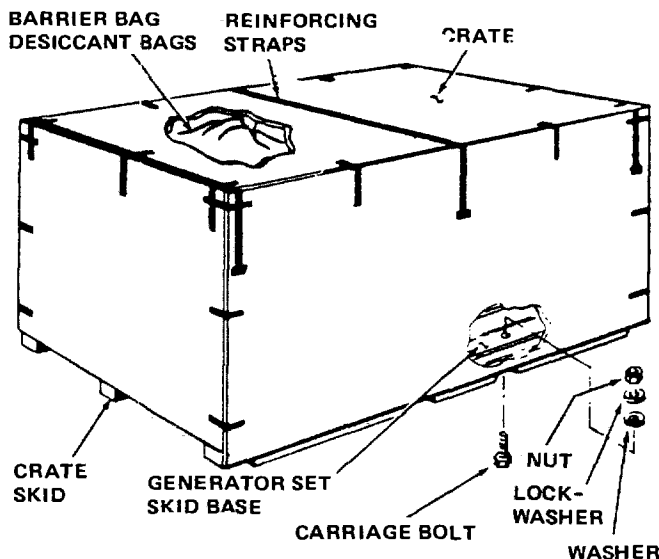

Figure 4-1 Shipping Crate

d. Battery Servicing.

Batteries are shipped "dry". Battery electrolyte must be requisitioned separately. Refer to table 3-1 for required quantity and type of electrolyte.

To activate and install batteries, proceed as follows:

(1) Refer to figure 3-2 to gain access to the batteries.

WARNING

Battery electrolyte contains sulfuric acid which can cause severe burns. It is highly toxic to the skin, eyes, and respiratory tract. Avoid all exposure. Skin, eye, and respiratory protection is required.

(2) Fill battery cells to slots in cells with undiluted battery electrolyte and install filler caps.

(3) Connect battery cables as shown in figure 4-14.

(4) Push in rollout tray assembly and install quick-release pins.

e. Radiator Servicing. Refer to paragraph 3-14. See table 3-1 and 4-1.

f. Engine Crankcase Servicing.

Refer to Section IV of this Chapter.

g. Fuel Tank Servicing.

Refer to paragraph 3-12e.

h. Ether Aid Servicing.

Refer to paragraph 4-91.

i. Engine Fuel Line Bleeding.

Refer to paragraph 4-87.

j. Preventive Maintenance.

Perform the "Before Operation" checks specified in table 3-2.

k. Inspection/Compliance with Paint and Marking Requirements.

(1) (AF only). Inspect generator for proper painting and marking (refer to AFR 35-1-3).

(2) Ensure that a noise level warning sign is stenciled on the top half of both rear (generator end of set) side doors (6, figure 4-10) as shown in figure 4-3.

4-5. INSTALLATION. Installation of the generator set involves placing it on a stable, level foundation in a well-ventilated area (including provisions for channeling exhaust fumes out of doors if required); electrically grounding the generator set; connecting the generator set to an auxiliary fuel line (if required); and connecting the required generator output to the load distribution lines through switchgear.

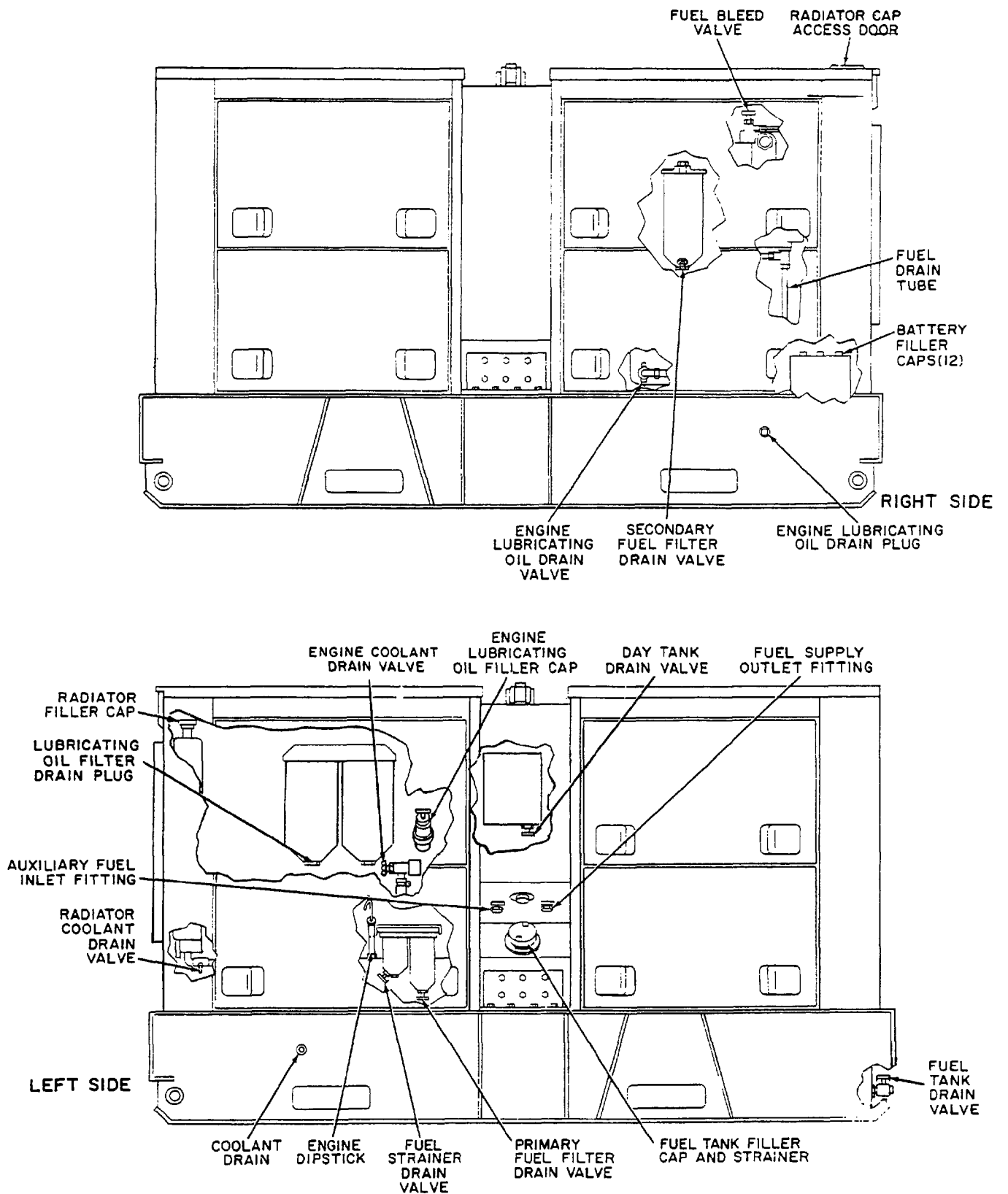

Figure 4-2. Location of Fill and Drain Points and Drain Valves

Table 4-1. Freezing Points, Composition, and Specific Gravities of Military Antifreeze Material

LOWEST EXPECTED AMBIENT TEMPERATURE °F (°C)	PINTS OF INHIBITED GLYCOL PER GAL. (LITER) OF COOLANT (1)	COMPOUND ANTIFREEZE ARCTIC (2)	ETHYLENE GLYCOL COOLANT SOLUTION SPECIFIC GRAVITY AT 68°F (20°C) (3)
+20 (-6.7)	1-1/2 (5.7)	Issued full strength and ready mixed for 0°F to -65°F (18°C to -54°C) temperatures for both initial installation and replenishment of losses.	1.022
+10 (-12.2)	2 (7.6)		1.036
0 (-17.8)	2-3/4 (10.4)		1.047
-10 (-23.3)	3-1/4 (12.3)		1.055
-20 (-28.9)	3-1/2 (13.3)		1.062
-30 (-34.4)	4 (15.2)		1.067
-40 (-40.0)	4-1/4 (16.1)		1.073
-50 (-45.6)	Arctic		
-60 (-51.1)	antifreeze preferred		
-75 (-59.4)			DO NOT DILUTE WITH WATER OR ANY OTHER SUBSTANCE.

(1) Maximum protection is obtained at 60 percent by volume (4.8 pints (2.3 liters) of ethylene glycol per gallon (3.785 liters) of solution).

(2) Military Specification MIL-A-117555 Arctic type, nonvolatile antifreeze compound is intended for use in the cooling system of liquid-cooled internal combustion engines. It is used for protection against freezing primarily in Arctic regions where the ambient temperature remains for extended periods close to -40°F (-40°C) or drops below to as low as -90°F (-67.8°C).

(3) Use an accurate hydrometer. To test hydrometer, use one part ethylene glycol antifreeze to two parts water. This should produce a hydrometer reading of 0°F (-18°C).

NOTE

Fasten a tag near the radiator filler cap indicating the type of antifreeze.

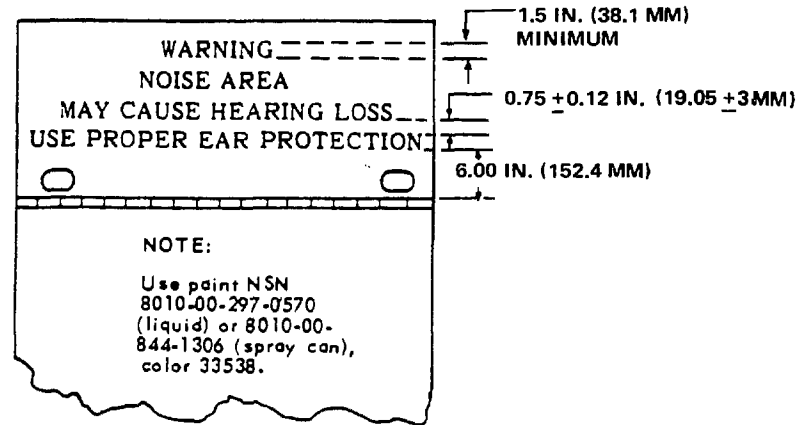

Figure 4-3. Noise Level Warning Sign

a. General. The generator set should be installed on a level site, clear of obstacles, and with ample ventilation. The site must be within 25 feet (7.6 meters) of any paralleled generator set and within 25 feet (7.6 meters) of any auxiliary fuel supply.

b. Outdoor Installation. When preparing for a permanent installation, be sure that the base is solid enough to support the weight of the unit. Refer to figure 4-4 for dimensions of the base. Select a location where there will be sufficient space on all sides for servicing and operation of the unit. When preparing a temporary installation, move the generator set as close to the worksite as practical. Use planks, logs, or other material for a base in an area where ground is soft.

c. Indoor Installation.

WARNING

Do not operate the generator set in an enclosed area unless the exhaust gases are piped to the outside. Inhalation of exhaust fumes will result in serious injury or death.

Keep the area well-ventilated at all times, so that the generator set will receive a maximum supply of air. Lift exhaust cap (see figure 1-1) and install a gas-tight, 4-inch ID exhaust

pipe (102 mm ID exhaust pipe) to the outside. Use as few bends in the pipe as possible. Provide metal shields for the exhaust pipe where it passes through flammable walls.

d. Leveling. The generator set is a portable unit and is designed to operate satisfactorily up to 15 degrees out of level. However, the unit should be as level as possible during operation.

e. Grounding.

WARNING

Do not operate the generator set unless the ground terminal stud has been connected to a suitable ground. Electrical faults in the generator set, load lines, or load equipment can cause injury or electrocution from contact with an ungrounded system.

The generator set must be grounded prior to operation. The ground can be, in order of preference, an underground metallic water piping system, a driven metal rod, or a buried metal plate. A ground rod must have a minimum diameter of 5/8 inch (41 mm) if solid or 3/4 inch (44 mm) if pipe, and must be driven to a minimum depth of 8 feet (2.44 meters). A ground plate must have a minimum area of 9 square feet (0.84 square meter) and must be buried at a minimum depth of 4 feet (1.22 meters). The

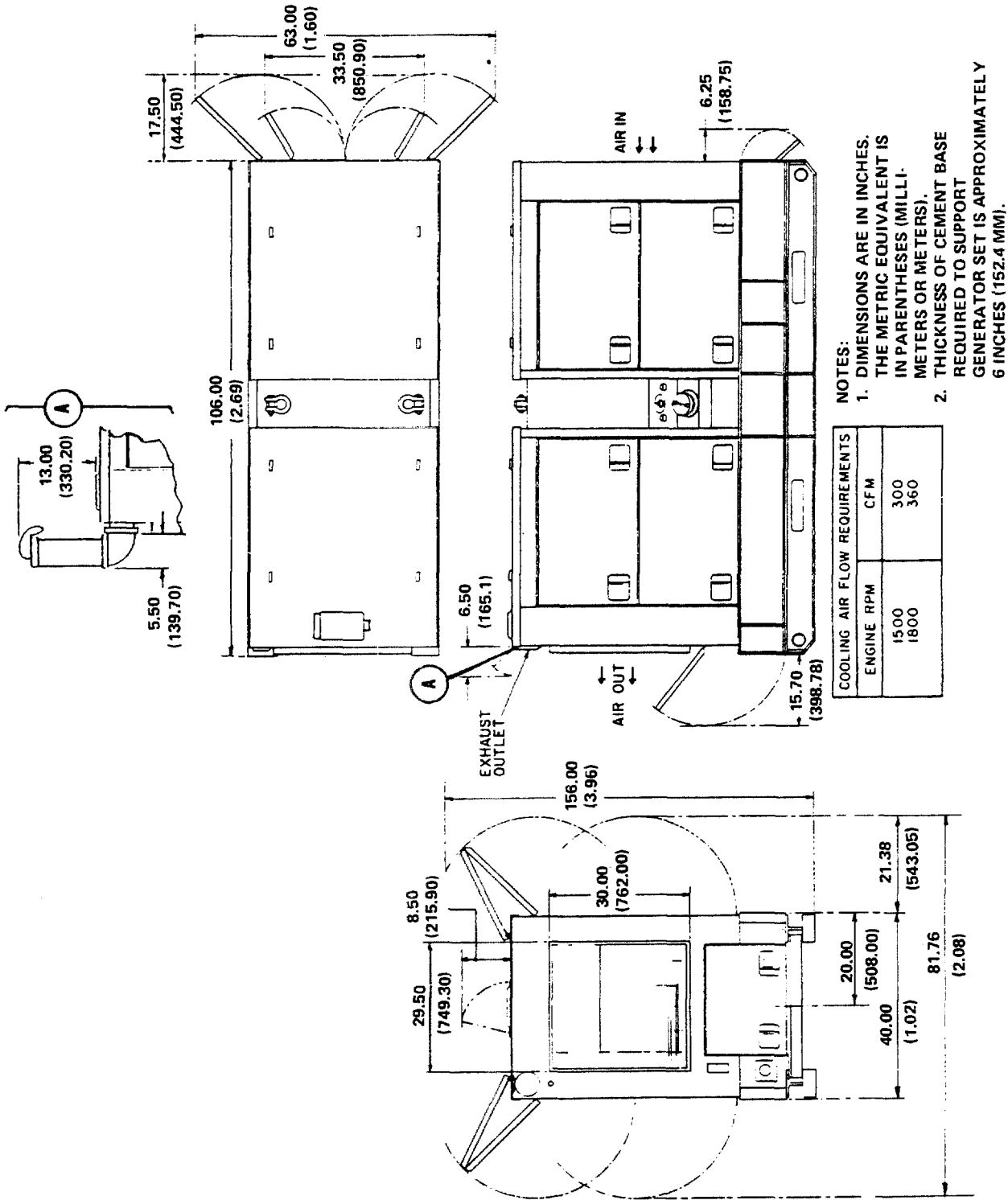
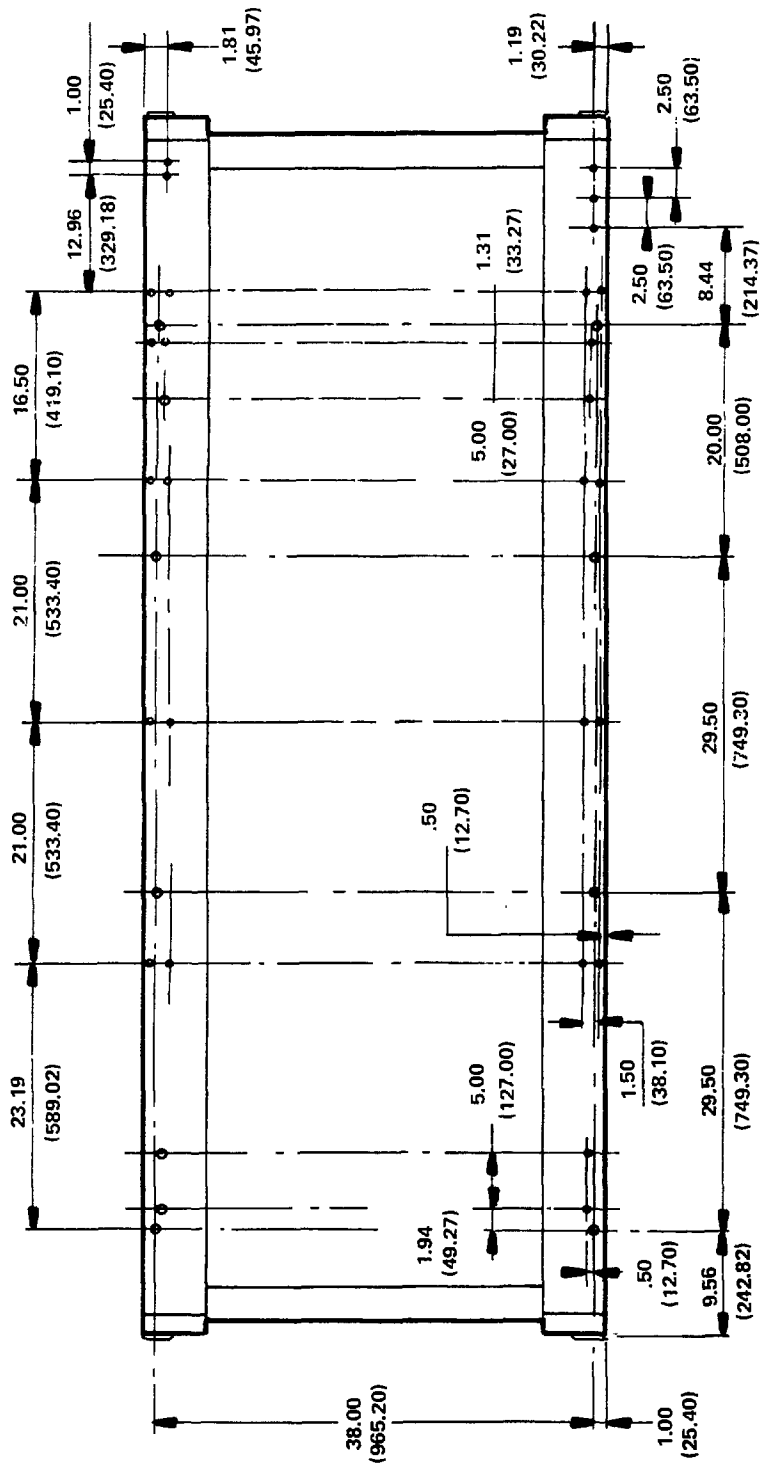

Figure 4-4. Installation Plan (Sheet 1 of 2)



BOTTOM VIEW

Figure 4-4. Installation Plan (Sheet 2 of 2)

ground lead must be at least No. 6 AWG (American Wire Gauge) copper wire and must be bolted or clamped to the rod, plate, or piping system. Connect the other end of the ground lead to the generator set ground terminal stud (figure 4-5). The following procedures are to be used to install grounding rods:

- (1) Install ground cable into slot in ground stud and tighten nut.
- (2) Connect coupling to ground rod and install driving stud in

coupling. Make sure driving stud is bottomed on ground rod.

(3) Drive ground rod into ground until coupling is just above the ground surface.

(4) Connect additional ground rods, as required, by removing driving stud from coupling and installing another ground rod in coupling. Make sure new ground rod is bottomed on ground rod previously installed. Connect another coupling on new ground rod and install driving stud.

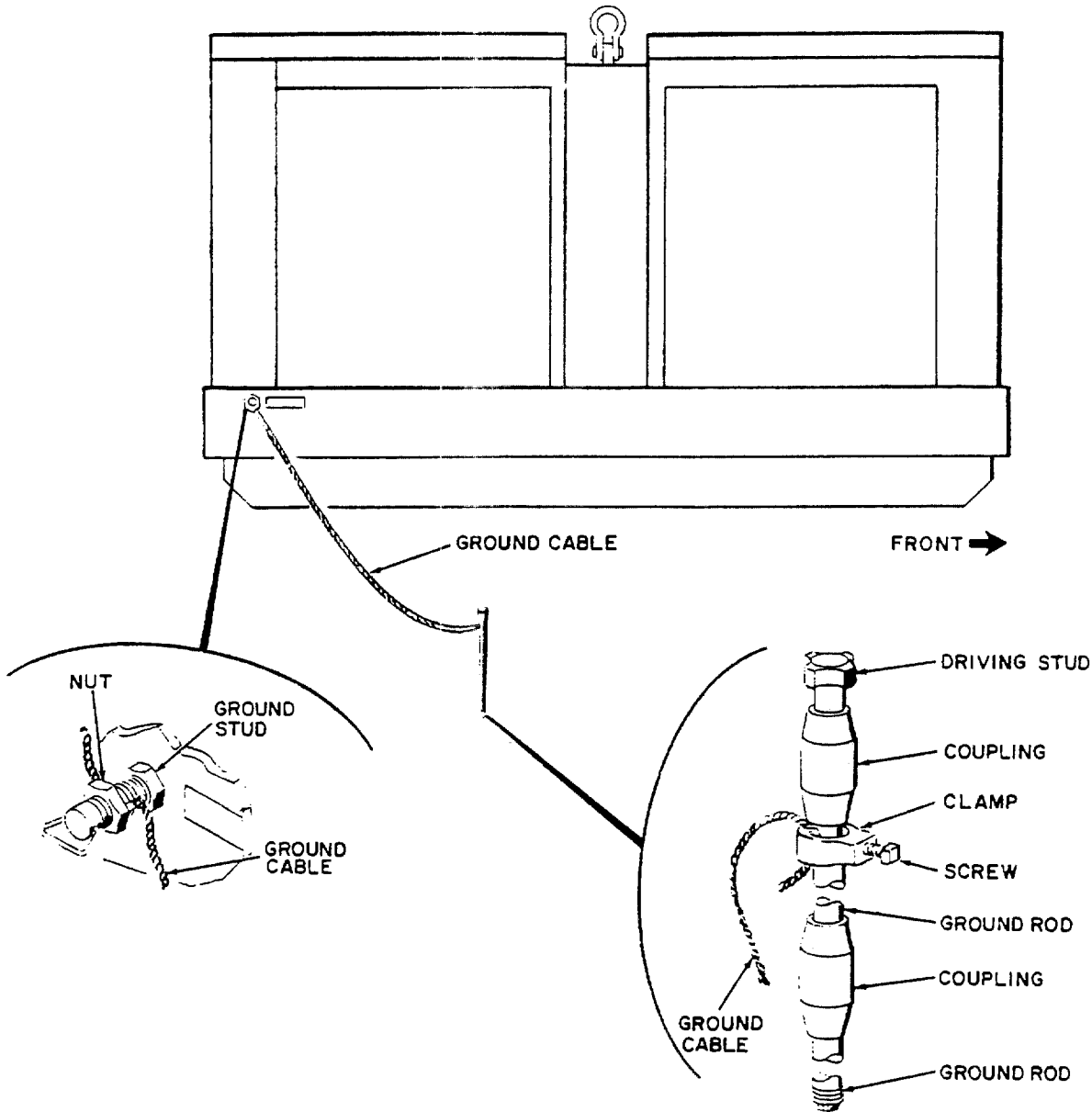

Figure 4-5. Ground Procedure



(5) After ground rods have been driven into the ground, remove driving stud and top coupling.

(6) Connect clamp and ground cable to top ground rod and secure by tightening screw.

f. Auxiliary Fuel Connection.

To connect an auxiliary fuel supply to the generator set, refer to figure 4-6 and perform steps (1) through (4), below. To utilize generator set as an auxiliary fuel supply perform steps (5) through (7), below.

(1) Position auxiliary fuel supply within 25 feet (7.6 meters) of generator set and not more than 12 feet (2.7 meters) below the transfer pumps.

(2) Remove cap from auxiliary fuel inlet fitting.

(3) Remove auxiliary fuel hose from its mount at left rear side of generator. Connect hose to auxiliary fuel inlet fitting and auxiliary fuel supply.

(4) Position fuel transfer valve to AUXILIARY.

(5) Remove cap from fuel supply outlet fitting.

(6) Connect fuel hose to fuel supply outlet fitting and then to external equipment requiring fuel.

(7) Position fuel transfer valve to OFF.

g. Load Connections. To connect load cables to generator set, refer to figure 4-7 and proceed as follows:

WARNING

Before attempting to connect load cables, make sure generator set is not operating and there is no input to the load.

(1) Open access door and disconnect transparent cover by

loosening six quick-release fasteners. Remove wrench from cover.

NOTE

Make sure proper phase relationship of load cables is maintained (that is, "A" to "A", "B" to "B", etc.).

(2) Attach load cables in the following order: L0, L3, L2, and L1 as specified in step (3), below. Neutral cable L0 must be connected to load terminal L0, load cable L1 to load terminal L1, load cable L2 to load terminal L2, and load cable L3 to load terminal L3.

(3) Insert load cables through protective sleeve. Attach cables to their respective load terminals, one cable to each terminal, by inserting cable in terminal slot and tightening terminal nut with the wrench which was clipped to the transparent cover. Install wrench on transparent cover and install cover.

(4) Tighten drawstring on protective sleeve to preclude entry of foreign matter. Close access door.

4-6. EQUIPMENT CONVERSION.

WARNING

Make sure generator set is not operating in a standby mode, or connected to a parallel bus when accomplishing voltage conversion. Death or injury may result.

a. Voltage Conversion. To convert generator set to 120/208 volts or 240/416 volts refer to figure 2-4.

b. Frequency Conversion. To convert the generator set to 50 or 60 Hertz operation, position engine manual speed control (6, figure 2-1) until HERTZ (frequency) meter (3, figure 2-2) reads required frequency.

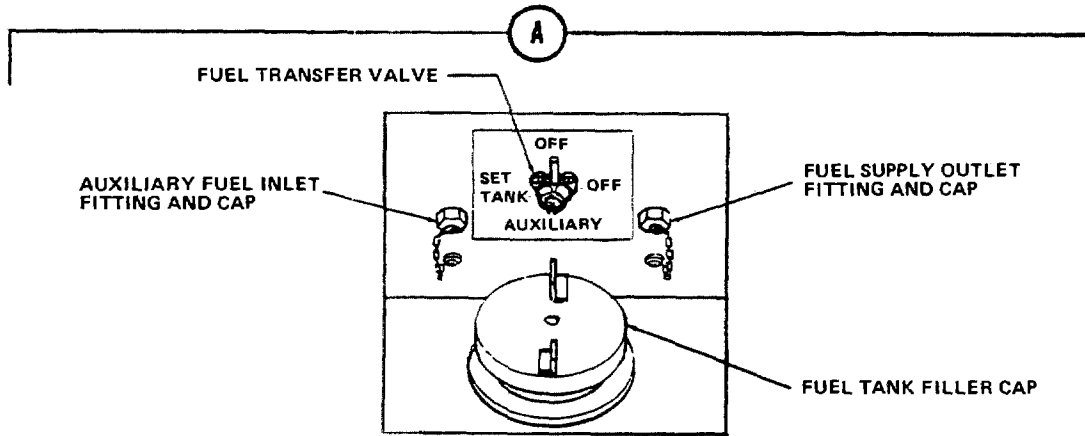
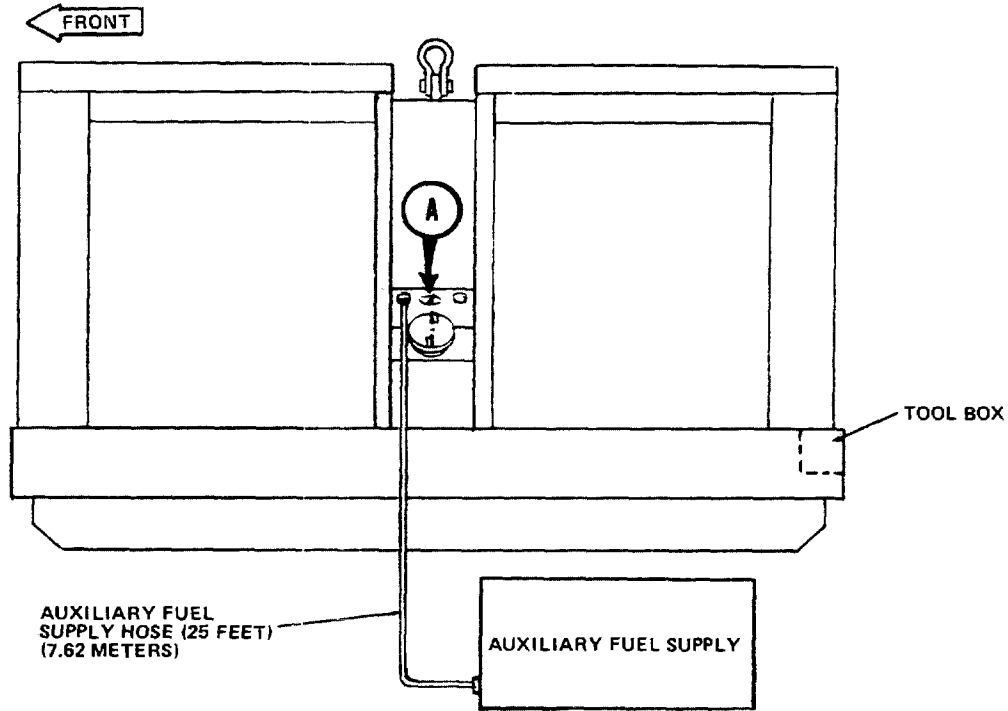

Figure 4-6. Fuel Connections

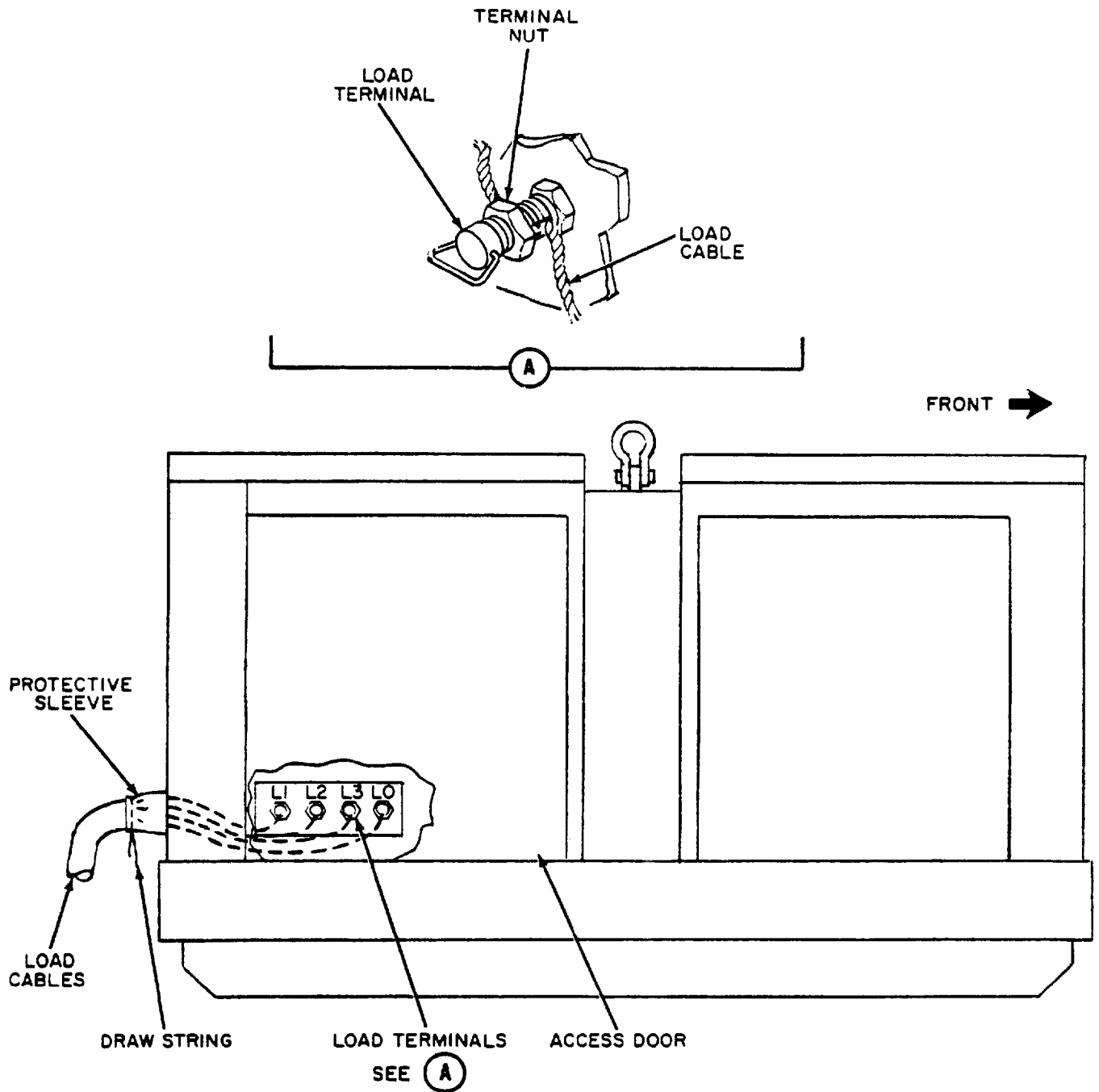

Figure 4-7. Load Cable Connections

## Section II. MOVEMENT TO A NEW WORK SITE

4-7. DISMANTLING FOR MOVEMENT. To dismantle the generator set for movement, proceed as follows:

### WARNING

Prior to disconnecting load cables, make sure generator set is not operating in a standby mode, or connected in parallel operation with other generator sets. Death or injury may result.

a. Open access door (refer to figure 4-7). Disconnect transparent cover by loosening six quick-release fasteners. Remove wrench from cover. Loosen terminal nuts using wrench provided, and remove load cables from terminals. Untie drawstring and remove load cables from generator set. Install wrench on transparent cover and install cover. Close access door.

b. Position fuel transfer valve to OFF (refer to figure 4-6). Disconnect auxiliary fuel supply hose, cap end fittings, and stow hose on its mount at left rear side of generator. Replace cap on auxiliary fuel inlet fitting.

c. Disconnect ground cable from ground stud by loosening nut (refer to figure 4-5). Disconnect ground cable from ground rod by loosening screw. Tape ends of ground cable to prevent unraveling and place cable in tool box.

d. Remove ground rod (use slide hammer -- see Basic Issue Items).

e. Disconnect any other external connections.

f. (A) Refer to Appendix B and make sure all basic issue items are with generator set and properly stowed.

g. Close and secure all access doors and panels.

h. Movement and Reinstallation.  
To move the generator set to a new worksite, proceed as follows:

### WARNING

Do not use a lifting device with a capacity of less than 10,000 pounds (4500 kg). Do not allow the generator set to swing while it is suspended. Failure to observe this warning may result in serious injury or death to personnel.

(1) If set is to be moved only a short distance and terrain is smooth, attach a towing device to towing eyes and tow generator set to new work site.

(2) If terrain is unsuitable for towing, place generator set on a forklift or crane as described in paragraph 4-2.

(3) For long distance movement, disconnect batteries, and tape battery cables in position to prevent movement. Drain fuel tank and coolant system. Refer to paragraph 1-8.

(4) Refer to paragraph 4-5 for installation procedures.

Section III. REPAIR PARTS; SPECIAL TOOLS; SPECIAL TEST, MEASUREMENT AND DIAGNOSTIC EQUIPMENT (TMDE); AND SPECIAL SUPPORT EQUIPMENT

4-8. **TOOLS AND EQUIPMENT.** Special tool(s) or equipment required by organizational maintenance personnel for maintenance of the generator set.

Douglas Kit (For Replacement of Governor Drive Seal):

- a. Arm (lever) Puller
- b. Seal Puller
- c. Seal Installer

4-9. **MAINTENANCE REPAIR PARTS.** Repair parts and equipment are listed and illustrated in the Organizational, Intermediate (Field), (Direct and General Support), and Depot Maintenance Repair Parts and Special Tools List (T.O. 35C2-3-442-14, TM5-6115-600-24P, NAVFAC P-8-628-24P, 5L-4-0764B) for this generator set.

Section IV. LUBRICATION INSTRUCTIONS

4-10. **GENERAL.** This section contains special organizational lubrication instructions not included in the lubrication order (figure 3-1). Army personnel should refer to DA Pam 310-4 and Marine Corps personnel to SL-1-3 to ensure the latest edition of the lubrication order (LO) is used.

4-11. **DRAIN ENGINE CRANKCASE.** Refer to figure 4-2 and proceed as follows:

- a. Remove engine lubrication oil drain plug and place container at drain.

- b. Open engine lubricating oil drain valve and drain oil into a container.

- c. Close drain valve and install drain plug. Refill crankcase (refer to figure 3-1). If crankcase is not refilled place tag on controls panel stating crankcase has been drained.

4-12. **ENGINE OIL FILTERS.** Service (replace) the oil filters as illustrated in figure 4-8.

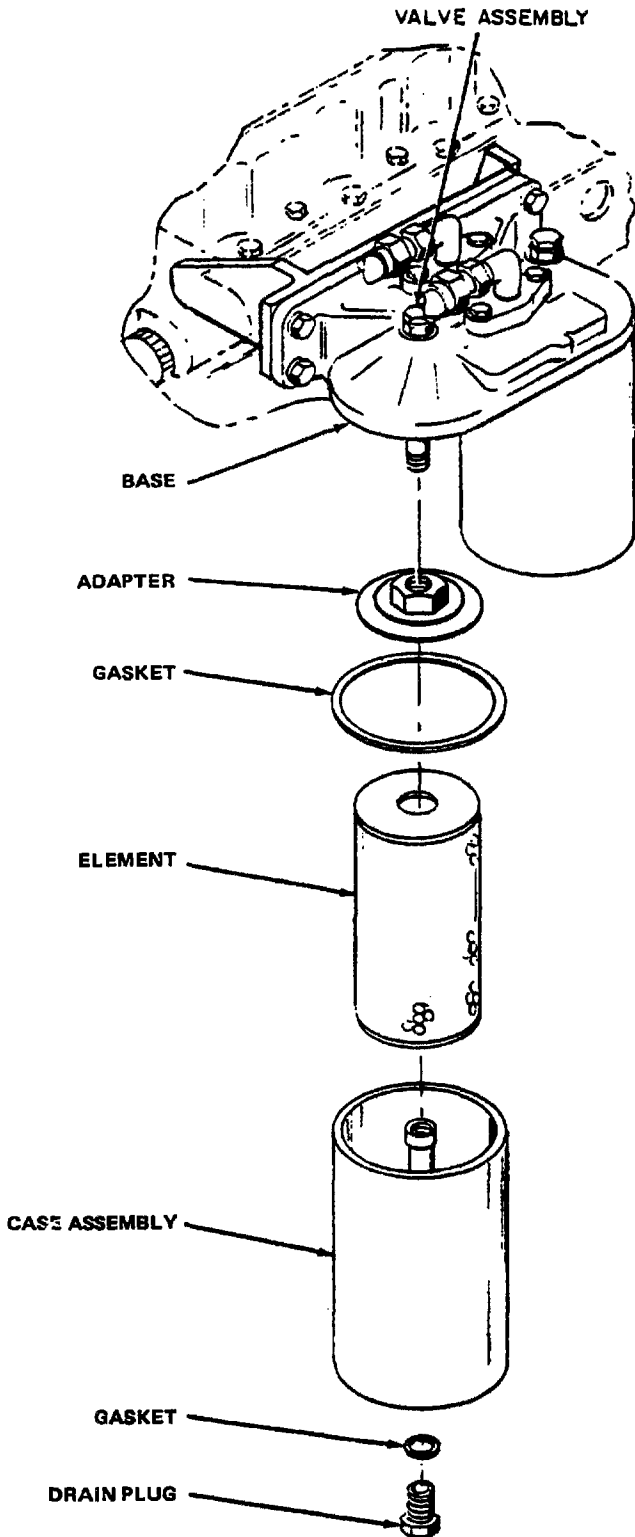

STEP 1. PLACE SUITABLE CONTAINER UNDER FILTERS.

NOTE

WHEN LOOSENING VALVE ASSEMBLY, PLACE WRENCH ON HEX IMMEDIATELY ABOVE BASE.

STEP 2. HOLD CASE ASSEMBLY AND LOOSEN VALVE ASSEMBLY UNTIL CASE ASSEMBLY IS FREE. REMOVE CASE ASSEMBLY, ELEMENT, GASKET, AND ADAPTER FROM BASE.

STEP 3. DISCARD ELEMENT AND GASKETS. CLEAN CASE ASSEMBLY, DRAIN PLUG, VALVE ASSEMBLY, ADAPTER, AND BASE WITH AN APPROVED CLEANING SOLVENT.

STEP 4. LUBRICATE NEW GASKET WITH CLEAN LUBRICATING OIL.

STEP 5. POSITION ADAPTER, GASKET, ELEMENT, AND CASE ASSEMBLY ON BASE AND SECURE WITH VALVE ASSEMBLY.

STEP 6. REMOVE CONTAINER AND FILL CRANKCASE WITH PROPER GRADE OF LUBRICATING OIL (REFER TO FIGURE 3-1).

F9800949

Figure 4-8. Lubricating Oil Filter, Servicing

## Section V. PREVENTIVE MAINTENANCE CHECKS AND SERVICES

4-13. GENERAL. To ensure that the generator set is ready for operation at all times, it must be inspected systematically so defects may be discovered and corrected before they result in serious damage or failure. Defects discovered during operation of the unit will be noted for future correction. Stop operation immediately if a deficiency is noted which would damage the equipment. All deficiencies and shortcomings will be recorded together with the corrective action taken on the applicable form. Air Force users shall refer to the applicable inspection manuals and work card sets in TO 35C2-3 Series for

periodic requirements and table 4-2 for detailed procedures. When the generator set is being operated continuously in dusty or sandy areas, lubricating oil filters must be serviced more frequently.

4-14. (A, N, MC) PREVENTIVE MAINTENANCE CHECKS AND SERVICES. Table 4-2 contains a tabulated listing of preventive maintenance checks and services which shall be performed by organizational maintenance personnel at weekly, monthly, and semi-annual intervals. The item numbers are listed consecutively and indicate the sequence of minimum requirements.

Table 4-2. Organizational Preventive Maintenance Checks and Services

INTERVAL			W - WEEKLY (40 HRS)	TOTAL T/H: 0.3
			M - MONTHLY (100 HRS)	TOTAL T/H: 2.7
			S - SEMI-ANNUAL (500 HRS)	TOTAL T/H: 13.9
ORGANIZATION			INSPECTION PROCEDURES	WORK TIME T/H
W	M	S		
1			FUEL FILLER CAP AND STRAINER Check filler cap for general condition and proper locking. Check strainer for cleanliness and clean as required (see paragraph 4-85).	0.1
2			FUEL TANK Drain water and sediment and refill with required fuel (see paragraph 3-12f).	0.2
	3		AIR FILTER ELEMENT Clean air filter element (refer to paragraph 3-16a).	0.3
	4		BATTERY ELECTROLYTE Check for correct specific gravity and level (see paragraph 3-9a).	0.2
	5		RADIATOR SHUTTER Open shutter manually to make sure it operates freely. Clean vane bushings with compressed air (see paragraph 3-18).	0.2
	6		BREATHER Check breather tube for clogging. Clean as required (see paragraph 4-96).	0.2
	7		PRIMARY FUEL FILTER AND STRAINER Service filter and strainer (see paragraph 4-85).	0.3
	8		FUEL TRANSFER PUMPS Service pumps (see paragraph 4-84).	0.5
	9		SECONDARY FUEL FILTER Service filter (see paragraph 4-86).	0.3
	10		ACCESS DOORS AND SEALS Inspect doors for proper latching. Inspect seals for condition and proper installation (see paragraph 4-21).	0.2



Table 4-2. Organizational Preventive Maintenance Checks and Services (Continued)

INTERVAL			W - WEEKLY (40 HRS)	TOTAL T/H: 0.3
			M - MONTHLY (100 HRS)	TOTAL T/H: 2.7
			S - SEMI-ANNUAL (500 HRS)	TOTAL T/H: 13.9
ORGANIZATION			INSPECTION PROCEDURES	WORK TIME T/H
W	M	S		
	11		GENERATOR SET Clean set (refer to paragraph 3-18).	0.5
		12	RADIATOR Check for leaks and signs of corrosion. Check coolant level (see paragraph 3-14b).	0.1
		13	BATTERIES AND CABLES Service batteries and check cables for security and absence of corrosion at connecting surfaces (see paragraph 3-9a).	0.5
		14	ENGINE Check for proper lubricating oil and or add as required (see paragraph 4-12 and 3-3). Check for loose connections; leaks in oil, fuel, and water system; free action of all moving parts; and fan belts for wear.	0.4
		15	FUEL FILTERS AND STRAINER Drain water and sediment (see paragraphs 4-85 and 4-86).	0.2
		16	FUEL (SET) TANK OR AUXILIARY FUEL SUPPLY HOSE Fill fuel (set) tank and check tank or auxiliary fuel hose for damage and leaks. Drain water and sediment (see paragraph 3-12f).	0.4
		17	DAY TANK Drain water and sediment and refill with required fuel (see paragraph 3-12c).	0.2
		18	FUEL FILLER CAP VENT VALVE Make sure vent valve is in open position and free of any dirt (see paragraph 4-94).	0.2

Table 4-2. Organizational Preventive Maintenance Checks and Services (Continued)

INTERVAL			W - WEEKLY (40 HRS)	M - MONTHLY (100 HRS)	S - SEMI-ANNUAL (500 HRS)	TOTAL T/H:	0.3
ORGANIZATION			INSPECTION PROCEDURES			WORK TIME T/H	
W	M	S					
		19	FUEL TRANSFER VALVE Check for proper operation in both SET TANK and AUXILIARY position (see paragraph 4-83).			0.2	
		20	GENERATOR Check air screens for cleanliness. One screen is on lower portion of end bell, and the other is around generator frame adjacent to engine flywheel housing. Check for signs of overheating such as blistering paint and burnt (darkened) areas (see paragraph 4-111).			0.2	
		21	GROUND AND LOAD CABLES Make sure all connections are clean (less corrosion) and tight.			0.2	
		22	METERS If necessary, zero adjust meters.			0.3	
		23	FAULT INDICATOR PANEL Check that indicators function properly (see paragraph 4-42).			0.5	
		24	GENERATOR SET Check for unusual noises and excessive vibration.			0.2	
		25	RADIATOR SHUTTER Check for proper operation. Shutter should open and close automatically to maintain normal engine operating temperature (see paragraph 4-100).			0.2	
		26	GENERATOR SET Lubricate in accordance with current lubrication order (see figure 3-1).			0.4	
		27	MUFFLER AND EXHAUST PIPE Check for general condition and security (see paragraph 4-96).			0.2	

Table 4-2. Organizational Preventive Maintenance Checks and Services (Continued)

INTERVAL			W - WEEKLY (40 HRS)	TOTAL T/H:	0.3
			M - MONTHLY (100 HRS)	TOTAL T/H:	2.7
			S - SEMI-ANNUAL (500 HRS)	TOTAL T/H:	13.9
ORGANIZATION			INSPECTION PROCEDURES		WORK TIME T/H
W	M	S			
		28	WIRING Inspect all wiring, wire harnesses and main generator leads for chafing, fraying, or damage to insulation; tightness of terminal lugs and connectors.		0.5
		29	LOW OIL PRESSURE SWITCH Check for proper operation (see paragraph 4-34).		0.5
		30	HIGH COOLANT TEMPERATURE SWITCH Check for proper operation (see paragraph 4-35).		0.5
		31	SPEED SWITCH Check for proper operation (see paragraph 4-33).		0.5
		32	BATTERY CHARGING ALTERNATOR Check for proper output (see paragraph 4-31).		0.5
		33	DAY TANK FUEL LEVEL SWITCH Check for proper operation (see paragraph 4-89).		1.0
		34	GOVERNOR THROTTLE LINKAGE Check for freedom of movement and proper adjustment (see paragraph 4-117).		0.5
		35	ENGINE MANUAL SPEED CONTROL Check for proper adjustment (see paragraph 4-59).		0.3
		36	COOLING SYSTEM Pressure test radiator cap and engine cooling system (see paragraph 4-99).		0.3

Table 4-2. Organizational Preventive Maintenance Checks and Services (Continued)

INTERVAL			W - WEEKLY (40 HRS)	TOTAL T/H: 0.3
			M - MONTHLY (100 HRS)	TOTAL T/H: 2.7
			S - SEMI-ANNUAL (500 HRS)	TOTAL T/H: 13.9
ORGANIZATION			INSPECTION PROCEDURES	WORK TIME T/H
W	M	S		
			NOTE	
			Engine valve lash shall be adjusted at 500 hours, checked and adjusted, as required, every 1000 hours thereafter.	
		37	ENGINE VALVES Adjust valve lash (see paragraph 4-126).	2.0
		38	ENGINE LUBE OIL AND FILTER Change at 300 hours (see paragraph 4-11 and 4-12).	0.5
			NOTE	
			Spectrometric Oil Analysis Program (SOAP) maybe used to determine oil change interval on units that have not reached recommended operating hour change requirements.	
			Lubricating oil standing in engines that are used infrequently or are in storage between seasons may tend to oxidize and require changing even though it is not dirty. Laboratory testing is the best way to determine whether oil or fuel is oxidizing under these conditions.	
			Units in standby service should be started once each week in locations where ambient temperature remains below 70 deg F (21.1 deg C) and contains a high percentage of humidity. Start engine, bring unit up to normal operating temperature and run for approximately thirty minutes.	
		39	BATTERY TERMINALS AND CABLE LUGS. Clean and grease every 500 hours.	1.0
		40	AIR FILTERS. Replace element (see paragraph 4-115).	0.5
		41	ALTERNATOR AND FAN BELTS Check fan belts for proper adjustment and general condition (see paragraph 3-9c).	0.5

## Section VI. TROUBLESHOOTING

### 4-15. GENERAL.

a. This section contains troubleshooting information for locating and correcting operating troubles which may develop in the generator set. Table 4-3 contains organizational troubleshooting procedures. Each malfunction for an individual component unit, or system is followed by a list of tests or inspections which will help you to

determine probable causes and corrective actions to take. You should perform the tests/inspections and corrective actions in the order listed.

b. This manual cannot list all malfunctions that may occur, nor all tests or inspections and corrective actions. If a malfunction is not listed or cannot be corrected by listed corrective actions, notify your supervisor.

Table 4-3. Troubleshooting, Organizational

---

MALFUNCTION  
TEST OR INSPECTION  
CORRECTIVE ACTION

---

1. ENGINE FAILS TO CRANK WHEN START-STOP-RUN SWITCH IS SET TO START (USUAL CONDITIONS).

Step 1. As START-STOP-RUN switch S2 is set to START listen for a distinct clicking sound coming from starter assembly B1.

If clicking sound is present, starter motor control circuitry is probably working properly and starter assembly B1 should be tested and replaced as required (refer to paragraph 4-39).

If no sound is heard, proceed to next step.

Step 2. Using hydrometer, check condition of both batteries. If hydrometer indicates that batteries have discharged but are not defective, use substitute batteries to start engine. Once engine has started, check BATTERY CHG AMMETER on control cubicle to determine if batteries are charging normally.

If batteries are not charging normally, test and replace alternator as required (refer to paragraphs 4-30 and 4-31).

If batteries are charging normally, proceed to next step.

Step 3. Using a multimeter, check for 24 V dc across crank relay K3 (located in Mode I relay box, A27), with START-STOP-RUN switch held in START position.

NOTE

To check this component refer to F0-1 and/or F0-2 to determine where these points are electrically accessible to meter probes.

If 24 V dc is present, check and replace K3 as required (refer to paragraph 4-36).

If 24 V dc is absent, refer to next step.

Table 4-3. Troubleshooting, Organizational (Continued)

MALFUNCTION	TEST OR INSPECTION	CORRECTIVE ACTION
1. ENGINE FAILS TO CRANK WHEN START-STOP-RUN SWITCH IS SET TO START (USUAL CONDITIONS). (Continued)		
	Step 4. Using a multimeter, check for 24 V dc across normally closed contacts of speed switch S9-1 (connected across pins A and B of J37) with START-STOP-RUN switch held in START position.	
		NOTE
		To check this component refer to F0-1 and/or F0-2 to determine where these points are electrically accessible to meter probes.
		If 24 V dc is present, check and replace S9-1 as required (refer to paragraph 4-33).
		If 24 V dc is absent, proceed to next step.
	Step 5. Using a multimeter, check for 24 V dc across diode CR3 (located on A5, a subassembly of Mode I relay assembly, A27) with START-STOP-RUN switch held in START position.	
		NOTE
		To check this component refer to F0-1 and/or F0-2 to determine where these points are electrically accessible to meter probes.
		If 24 V dc is present, check and replace CR3 as required.
		If 24 V dc is absent, proceed to next step.
	Step 6. Using a multimeter, check for 24 V dc across contacts 4 and 5 of BATTLE SHORT switch S7 (located on the control cubicle) with START-STOP-RUN switch held in START position.	
		If 24 V dc is present, check and replace BATTLE SHORT switch S7 as required (refer to paragraph 4-38).
		If 24 V dc is absent, proceed to next step.
	Step 7. Using a multimeter, check for 24 V dc across contacts 11 and 12 of START-STOP-RUN switch S2 (located on the control cubicle) with START-STOP-RUN switch held in START position.	

Table 4-3. Troubleshooting, Organizational (Continued)

MALFUNCTION	TEST OR INSPECTION	CORRECTIVE ACTION
1. ENGINE FAILS TO CRANK WHEN START-STOP-RUN SWITCH IS SET TO START (USUAL CONDITIONS). (Continued)		<p>If 24 V dc is present, check and replace START-STOP-RUN switch S2 as required (refer to paragraph 4-38).</p> <p>If 24 V dc is absent, check and replace as required CKT BRK switch CB1 (refer to paragraph 4-37).</p>
2. ENGINE CRANKS SLOWLY WHEN START-STOP-RUN SWITCH IS SET TO START.		<p>Check starter assembly B1 (refer to paragraph 4-39).</p> <p>If starter assembly B1 is defective it should be replaced or repaired as required (refer to paragraph 4-39).</p> <p>If starter assembly B1 is not defective, refer malfunction to next higher level of maintenance.</p> <p>Use slave receptacle (SR1 or SR2) when extra cranking power is required.</p>
3. ENGINE CRANKS PROPERLY BUT ENGINE WILL NOT START.		<p style="text-align: center;"><b><u>WARNING</u></b></p> <p>Clip meter test leads in place before cranking engine. Maintain a safe distance between yourself and engine while it is being cranked.</p> <p>Step 1. Using a multimeter, check for 24 V dc across engine shutdown solenoid L1 (located adjacent to fuel injection pump) while cranking engine just long enough to note meter reading. Use slave receptacle (SR1 or SR2) when extra cranking power is required.</p> <p style="text-align: center;">NOTE</p> <p>To check this component refer to FO-1 and/or FO-2 to determine where these points are electrically accessible to meter probes.</p> <p>If 24 V dc is present, replace L1 (refer to paragraph 4-40).</p> <p>If 24 V dc is absent, proceed to next step.</p>



Table 4-3. Troubleshooting, Organizational (Continued)

---

MALFUNCTION  
TEST OR INSPECTION  
CORRECTIVE ACTION

---

3. ENGINE CRANKS PROPERLY BUT ENGINE WILL NOT START. (Continued)

WARNING

Clip meter test leads in place before cranking engine. Maintain a safe distance between yourself and engine while it is being cranked.

- Step 2. Using a multimeter, check for 24 V dc across normally closed contacts of overspeed switch S9-3 (connected across pins G and H of P37) while cranking engine just long enough to note meter reading.

NOTE

To check this component refer to F0-1 and/or F0-2 to determine where these points are electrically accessible to meter probes.

If 24 V dc is present, check and replace S9-3 as required (refer to paragraph 4-33).

If 24 V dc is absent, proceed to next step.

- Step 3. Using a multimeter, check for 24 V dc across contacts 5 and 6 of START-STOP-RUN switch S2 (located in the control cubicle) while cranking engine just long enough to note meter reading.

If 24 V dc is present, check and replace S2 as required (refer to paragraph 4-38).

If 24 V dc is absent, check and repair, as required, wiring between S2 and CB1. If not defective, proceed to next step.

- Step 4. Check primary fuel filter and strainer elements as described in paragraph 4-85.

If clogged or defective service as required (refer to paragraph 4-85).

If in good condition, proceed to next step.

Table 4-3. Troubleshooting, Organizational (Continued)

---

MALFUNCTION  
TEST OR INSPECTION  
CORRECTIVE ACTION

---

Step 5. Check secondary filter element as described in paragraph 4-86.

If clogged or defective service as required (refer to paragraph 4-86).

If in good condition, proceed to next step.

Step 6. Check turborcharger as described in paragraph 4-116.

If defective, replace as described in paragraph 4-116.

If in good condition, refer malfunction to next higher level of maintenance.

4. ENGINE STARTS PROPERLY BUT SHUTS DOWN UPON RELEASING START-STOP-RUN SWITCH TO RUN (WITH NO FAULT INDICATION).

Step 1. Connect a jumper across contacts C and B of J42 to temporarily short out oil pressure switch OP. Connect multimeter test leads across contacts 2 and 8 of relay K1 (located on control panel relay assembly A4) and check for 24 V dc.

NOTE

To check this component refer to FO-1 and/or FO-2 to determine where these points are electrically accessible to meter probes.

If 24 V dc is present, check and replace relay K1 or oil pressure switch OP as required (refer to paragraph 4-34).

If 24 V dc is absent, proceed to next step.

Step 2. Unplug connector J43 from alternator and using multimeter check for 24 V dc across contacts 2 and 8 of relay K1.

If 24 V dc is present, check and replace alternator as required (refer to paragraph 4-31).

If 24 V dc is absent, plug connector J43 into alternator and proceed to next step.

Table 4-3. Troubleshooting, Organizational (Continued)

---

MALFUNCTION  
TEST OR INSPECTION  
CORRECTIVE ACTION

---

4. ENGINE STARTS PROPERLY BUT SHUTS DOWN UPON RELEASING START-STOP-RUN SWITCH TO RUN (WITH NO FAULT INDICATION). (Continued)

Step 3. Using multimeter, check for 24 V dc across contracts 3 and 4 of overvoltage relay K2 (located in tactical relay assembly A29.)

NOTE

To check this component refer to F0-1 and/or F0-2 to determine where these points are electrically accessible to meter probes.

If 24 V dc is present, refer testing and replacement of K2 to next higher level of maintenance.

If 24 V dc is absent, proceed to next step.

Step 4. Using multimeter, check for 24 V dc across contacts of high coolant temperature switch WT.

NOTE

To check this component refer to F0-1 and/or F0-2 to determine where these points are electrically accessible to meter probes.

If 24 V dc is present, check and replace switch WT (refer to paragraph 4-35).

If 24 V dc is absent, proceed to next step.

Step 5. Using multimeter, check for 24 V dc across contacts 4 and 16 of relay K8 (located on assembly A5 of Mode I relay box).

NOTE

To check this component refer to F0-1 and/or F0-2 to determine where these points are electrically accessible to meter probes.

If 24 V dc is present, check and replace relay K8 as required (refer to paragraph 4-36).

If 24 V dc is absent, disconnect jumper clip leads from across oil pressure switch OP and check wiring associated with relays K1, K2, and K8, and switch OP and WT.

Table 4-3. Troubleshooting, Organizational (Continued)

---

MALFUNCTION  
TEST OR INSPECTION  
CORRECTIVE ACTION

---

5. ENGINE SHUTS DOWN AND WILL NOT RESTART.

Step 1. If COOLANT HIGH TEMP indicator is lit, and coolant level is normal, test coolant thermostat (refer to paragraph 4-105).

Replace coolant thermostat if defective.

If high coolant temperature condition persists, proceed to next step.

Step 2. Refer to paragraph 4-107 and check fan belt tension.

Adjust or replace belt as required.

If high coolant temperature conditions persists, proceed to next step.

Step 3. Refer to paragraph 3-14 and inspect cooling system hoses and water pump.

Replace hoses and/or water pump in accordance with paragraph 4-102 and/or 4-104.

If high coolant condition persists, refer to next higher level of maintenance.

Step 4. If OVER SPEED indicator is lit, toggle TEST OR RESET switch on FAULT INDICATOR panel to up.

If OVER SPEED indicator goes out, inspect and/or adjust governor and governor throttle linkages (refer to paragraph 4-117).

If OVER SPEED indicator stays lit, check and replace speed switch S9-3 as required (refer to paragraph 4-33).

Step 5. If OVER VOLT indicator is lit, toggle TEST OR RESET switch on FAULT INDICATOR panel to up.

If OVER VOLT indicator goes out, refer exciter regulator assembly A11 to next higher level of maintenance.

If OVER VOLT indicator stays lit, inspect overvoltage relay K2 and refer to next higher level of maintenance.

Table 4-3. Troubleshooting, Organizational (Continued)

MALFUNCTION  
 TEST OR INSPECTION  
 CORRECTIVE ACTION

6. FAULT INDICATOR PANEL INDICATES FAULT (ENGINE OPERATION IS NORMAL).

- Step 1. If LOW OIL PRESSURE indicator is lit, toggle TEST OR RESET switch on FAULT INDICATOR panel to up. If LOW OIL PRESSURE indicator stays lit, connect multimeter across oil pressure switch OP (connected across A and D of J42) and check for 24 V dc.

NOTE

To check this component refer to FO-1 and/or FO-2 to determine where these points are electrically accessible to meter probes.

If 24 V dc is present, check and replace oil pressure switch OP as required (refer to paragraph 4-34).

If 24 V dc is absent, check and replace FAULT INDICATOR panel A9 as required (refer to paragraph 4-42).

- Step 2. If OVER SPEED indicator is lit, toggle TEST OR RESET switch on FAULT INDICATOR panel to up. If OVER SPEED indicator stays lit, connect multimeter across overspeed switch S9-3 (connected across F and J of J37) and check for 24 V dc.

NOTE

To check this component refer to FO-1 and/or FO-2 to determine where these points are electrically accessible to meter probes.

If 24 V dc is present, check and replace overspeed switch S9-3 as required (refer to paragraph 4-33).

If 24 V dc is absent, check and replace FAULT INDICATOR panel A9 as required (refer to paragraph 4-42).

- Step 3. If COOLANT HIGH TEMP indicator is lit, toggle TEST OR RESET switch on FAULT INDICATOR panel to up. If COOLANT HIGH TEMP indicator stays lit, connect multimeter across coolant temperature switch WT (connected across B and C of J14) and check for 24 V dc.

---

MALFUNCTION  
TEST OR INSPECTION  
CORRECTIVE ACTION

---

6. FAULT INDICATOR PANEL INDICATES FAULT (ENGINE OPERATION IS NORMAL). (Continued)

NOTE

To check this component refer to FO-1 and/or FO-2 to determine where these points are electrically accessible to meter probes.

If 24 V dc is present, check and replace coolant temperature switch WT as required (refer to paragraph 4-35).

If 24 V dc is absent, check and replace FAULT INDICATOR panel A9 as required (refer to paragraph 4-42).

- Step 4. If NO FUEL indicator is lit, toggle TEST OR RESET switch on FAULT INDICATOR panel to up. If NO FUEL indicator stays lit, connect multimeter across contacts 5 and 17 of fuel level relay K8 (located on A5 assembly of the Mode I relay assembly).

NOTE

To check this component refer to FO-1 and/or FO-2 to determine where these points are electrically accessible to meter probes.

If 24 V dc is present, check and replace fuel level relay K8 as required (refer to paragraph 4-36).

If 24 V dc is absent, check and replace FAULT INDICATOR panel A9 as required (refer to paragraph 4-42).

7. ENGINE RUNS ERRATICALLY OR MISFIRES.

- Step 1. Refer to figures 4-46 and 4-49 and check fuel line into and out of the fuel injection pump for damage or blockage.

If fuel lines are defective, refer to paragraph 4-90 for replacement procedures.

If fuel lines are free of obstruction or defect, refer malfunction to next higher level of maintenance.

Table 4-3. Troubleshooting, Organizational (Continued)

---

MALFUNCTION  
TEST OR INSPECTION  
CORRECTIVE ACTION

---

7. ENGINE RUNS ERRATICALLY OR MISFIRES. (Continued)

Step 2. Service the air cleaners and inspect turbocharger for any defects.

Clear any blockages, or service air cleaners as necessary (refer to paragraph 3-16). Inspect turbocharger (refer to paragraph 4-116).

If air intake system and turbocharger appears to be working properly, refer to next higher level of maintenance.

Step 3. If feasible, temporarily disconnect the generator load by setting CKT BRK switch on the control cubicle to OPEN.

If engine still runs erratically or misfires, refer malfunction to next higher level of maintenance.

If engine now runs smoothly, reconnect load by setting CKT BRK switch to CLOSE, and proceed to next step.

Step 4. Check KILOWATTS and PERCENT RATED CURRENT meters on control cubicle.

If readings indicate excessive power draw, rearrange load distribution to restore normal power consumption.

If readings are normal, refer malfunction to next higher level of maintenance.

8. ENGINE EXHAUST WHITE OR BLUE.

Step 1. Check for excessive lube oil using dipstick gage.

If lube oil level is too high, drain crankcase (refer to paragraph 4-11) until proper level is attained.

Step 2. Visually check engine fuel for contamination.

If engine fuel is not contaminated, refer malfunction to next higher level of maintenance.

Table 4-3. Troubleshooting, Organizational (Continued)

---

MALFUNCTION  
TEST OR INSPECTION  
CORRECTIVE ACTION

---

9. GENERATOR OUTPUT FREQUENCY INCORRECT.

Step 1. Check frequency meter with a master meter.

If frequency appears to be correct, replace HERTZ meter M6 and frequency convertor A2 as a unit (both are located on the control cubicle).

If frequency is incorrect, proceed to next step.

Step 2. Inspect and/or adjust governor and governor throttle linkages (refer to paragraphs 4-117 and 4-118). If governor and linkages appear to function normally, proceed to next step.

Step 3. Pull dipstick and check for fuel leakage that might be working its way into the lube oil by way of the crankcase. If engine appears not to have any leakage, refer malfunction to next higher level of maintenance.

10. GENERATOR OUTPUT VOLTAGE INCORRECT.

Step 1. Using multimeter check output ac voltage at the convenience receptacle.

Switch the AMPS-Volts selector switch S8 to different testing positions and monitor the output voltage. If output voltage is incorrect in only one position, check and replace switch S8 (refer to paragraph 4-51). If S8 is not defective, refer malfunction to next higher level of maintenance (generator may be defective). If voltage is incorrect in all positions, check and replace VOLTS AC meter M9 as required (refer to paragraph 4-44).

If multimeter reading is incorrect (that is, fails to reads required voltage), proceed to next step

Step 2. Inspect VOLTAGE ADJUST rheostat R2 on the control cubicle according to paragraph 4-48.

If defective, replace in accordance with paragraph 4-48.

If not defective, proceed to next step.



Table 4-3. Troubleshooting, Organizational (Continued)

---

MALFUNCTION  
TEST OR INSPECTION  
CORRECTIVE ACTION

---

10. GENERATOR OUTPUT VOLTAGE INCORRECT. (Continued)

- Step 3. With VOLTAGE SENSING switch (on control cubicle) S5 set to LOCAL, use multimeter to measure AC voltage across terminals 1 and 2 and then 4 and 5 of S5.

NOTE

If VOLTAGE SENSING switch is set to REMOTE, check terminals 2 and 3, and then 5 and 6.

If multimeter reads any voltage above zero, check and replace switch S5 as required (refer to paragraph 4-50).

If multimeter reads zero (switch multimeter range selector to lowest range), proceed to next step.

- Step 4. With VOLTAGE SENSING switch set to LOCAL, use multimeter to measure AC voltage across contacts 10 and 11, and then 5 and 6 of voltage sensing relay K6 (located on relay assembly A4).

NOTE

If VOLTAGE SENSING switch is set to REMOTE, check contacts 10 and 12, and then 6 and 4.

If multimeter reads any voltage above zero, check and replace relay assembly A4 (located in control cubicle assembly A3) (refer to paragraph 4-60).

If multimeter reads zero (switch multimeter range selector to lowest range), proceed to next step.

- Step 5. Inspect VOLTAGE ADJUST rheostat R2 on the control cubicle according to paragraph 4-48 and, if not defective, refer malfunction to next higher level of maintenance.

- Step 6. Shut engine down. Connect multimeter across coil of field flash relay K5 (13 and 15 of DC relay assembly A5 located in Mode I relay assembly A27).

If multimeter does not momentarily indicate 24 V dc, check and replace speed switch S9-1, as required (refer to paragraph 4-44).

Table 4-3. Troubleshooting, Organizational (Continued)

---

MALFUNCTION
TEST OR INSPECTION
CORRECTIVE ACTION

---

10. GENERATOR OUTPUT VOLTAGE INCORRECT. (Continued)

If multimeter momentarily indicates 24 V dc, check and replace relay K5 as required (refer to paragraph 4-47).

If relay K5 is not defective, refer malfunction to next higher level of maintenance.

11. GENERATOR CKT BRK INDICATOR GOES OUT (LOAD DISCONNECTS).

Check FAULT INDICATOR panel to see which, if any, generator fault indicator is lit.

If either the SHORT CIRCUIT or OVERLOAD indicators are lit, the malfunction is contained within the external load.

If REVERSE POWER indicator is lit, refer to the paralleling procedure in paragraph 2-5. If the REVERSE POWER indicator still comes on, refer malfunction to next higher level of maintenance.

If OVER VOLT indicator is lit, refer to malfunction 10 of this table.

If there is no fault indication, check and replace main circuit breaker CB2 (refer to paragraph 4-72).

12. FAULT INDICATOR PANEL INDICATES FAULT BUT GENERATOR CKT BRK INDICATOR STAYS LIT (LOAD REMAINS CONNECTED).

Step 1. If SHORT CIRCUIT indicator is lit, toggle TEST OR RESET switch on FAULT INDICATOR panel to up. If SHORT CIRCUIT indicator stays lit, connect multimeter across contacts 7 and 8 of short circuit relay K13 (located in tactical relay assembly A29) and check for 24 V dc.

NOTE

To check this component refer to FO-1 and/or FO-2 to determine where these points are electrically accessible to meter probes.

Table 4-3. Troubleshooting, Organizational (Continued)

---

MALFUNCTION  
TEST OR INSPECTION  
CORRECTIVE ACTION

---

12. FAULT INDICATOR PANEL INDICATES FAULT BUT GENERATOR CKT BRK INDICATOR STAYS LIT (LOAD REMAINS CONNECTED). (Continued)

If 24 V dc is present, inspect relay K13 and refer malfunction to next higher level of maintenance.

If 24 V dc is absent, check and replace FAULT INDICATOR panel A9 as required (refer to paragraph 4-42).

- Step 2. If REVERSE POWER indicator is lit, toggle TEST OR RESET switch on FAULT INDICATOR panel to up. If REVERSE POWER indicator stays lit, connect multimeter across contacts 5 and 6 of reverse power relay K15 (located in tactical relay assembly A29) and check for 24 V dc.

NOTE

To check this component refer to F0-1 and/or F0-2 to determine where these points are electrically accessible to meter probes.

If 24 V dc is present, inspect relay K15 and refer malfunction to next higher level of maintenance.

If 24 V dc is absent, check and replace FAULT INDICATOR panel A9 as required (refer to paragraph 4-42).

- Step 3. If OVER LOAD indicator is lit, toggle TEST OR RESET switch on FAULT INDICATOR panel to up. If OVER LOAD indicator stays lit, connect multimeter across contacts 3 (normally closed) and 4 (normally open) of over load relay K14 (located in tactical relay assembly A29) and check for 24 V dc.

NOTE

To check this component refer to F0-1 and/or F0-2 to determine where these points are electrically accessible to meter probes.

If 24 V dc is present, inspect relay K14 and refer malfunction to next higher level of maintenance.

If 24 V dc is absent, check and replace FAULT INDICATOR panel A9 as required (refer to paragraph 4-42).

Table 4-3. Troubleshooting, Organizational (Continued)

---

MALFUNCTION
TEST OR INSPECTION
CORRECTIVE ACTION

---

12. FAULT INDICATOR PANEL INDICATES FAULT BUT GENERATOR CKT BRK INDICATOR STAYS LIT (LOAD REMAINS CONNECTED). (Continued)

Step 4. If OVER VOLT indicator is lit, toggle TEST OR RESET switch on FAULT INDICATOR PANEL to up. If OVER VOLT indicator stays lit, connect multimeter across contacts 7 and 8 of over volt relay K2 (located in tactical relay assembly A29) and check for 24 V dc.

NOTE

To check this component refer to FO-1 and/or FO-2 to determine where these points are electrically accessible to meter probes.

If 24 V dc is present, inspect relay K2 and refer malfunction to next higher level of maintenance.

If 24 V dc is absent, check and replace FAULT INDICATOR panel A9 as required (refer to paragraph 4-42).

13. ONE OR BOTH SYNCHRONIZATION LIGHTS DO NOT COME ON DURING PARALLEL OPERATION SETUP.

Step 1. Use multimeter to measure AC voltage across terminals 5 and 6, and then 2 and 3 of PARALLEL OPERATION switch S6.

If multimeter reads any voltage above zero, check and replace switch S6 as required (refer to paragraph 4-50).

If multimeter reads zero, proceed to next step.

Step 2. Check parallel lights relay K7, resistors R3, R6, R7, R8 and R9 and bridge rectifier CR4 (all located in A5 assembly of Mode I relay box).

14. ENGINE LACKS POWER (UNABLE TO HANDLE RATED LOAD).

Step 1. Check primary fuel filter and strainer elements.

If clogged or defective service as required (refer to paragraph 4-85).

If in good condition, proceed to next step.

Table 4-3. Troubleshooting, Organizational (Continued)

---

MALFUNCTION  
TEST OR INSPECTION  
CORRECTIVE ACTION

---

14. ENGINE LACKS POWER (UNABLE TO HANDLE RATED LOAD). (Continued)

Step 2. Check secondary filter elements.

If clogged or defective service as required (refer to paragraph 4-86).

If in good condition, proceed to next step.

Step 3. Check turborcharger as described in paragraph 4-116.

If defective, replace as described in paragraph 4-116.

If in good condition, proceed to next step.

Step 4. Check for air in fuel system -- examine fittings to ensure tightness.

If there are any indications of air in fuel system, it should be bled as described in paragraph 4-87.

If fuel system functions properly, refer malfunction to next higher level of maintenance.

Step 5. Check adjustment of valve lifters (valve lash) as described in paragraph 4-125.

If valve lash is incorrect, adjust as described in paragraph 4-125.

If valve lash is correct, refer malfunction to next higher level of maintenance.

15. FUEL LEVEL GAGE READING OBVIOUSLY INCORRECT.

Step 1. Check fuel level gage M3 (refer to paragraph 4-55).

If M3 is defective, replace (refer to paragraph 4-55).

If M3 is not defective, proceed to next step.

Step 2. Check fuel level transmitter MT3 (refer to paragraph 4-67).

If MT3 is defective, replace (refer to paragraph 4-67).

If MT3 is not defective, check and repair, as required, wiring associated with M3 and MT3 (refer to FO-2).

## Section VII. RADIO INTERFERENCE SUPPRESSION

4-16. GENERAL METHODS USED TO ATTAIN A PROPER SUPPRESSION. Essentially, suppression is attained by providing a low-resistance path to ground for the stray currents. The methods used include shielding high-frequency wires, grounding the frame with bonding straps, and using capacitors and resistors.

4-17. INTERFERENCE SUPPRESSION COMPONENTS. The generator set utilizes a diode assembly to suppress radio interference. The diode assembly consists of diodes CR27 and CR28 which reduce transient type interference generated in the day tank fuel solenoid valve during operation. The diode assembly is mounted to the day tank adjacent to the ether starting aid.

4-18. REPLACEMENT OF SUPPRESSION COMPONENTS. Refer to figure 4-9 to replace the radio interference suppression components.

4-19. TESTING OF RADIO INTERFERENCE SUPPRESSION COMPONENTS. Test diodes using a suitable diode tester; replace defective diodes. If diode tester is not available, test diodes using ohmmeter. Check forward and reverse resistance of diodes. Measure from anode (+) to cathode (-); value should be low. Reverse leads; value should be infinity. If test equipment is not available and interference is indicated, isolate the cause of interference by the trial-and-error method of replacing each diode in turn until the cause of interference is located and eliminated.

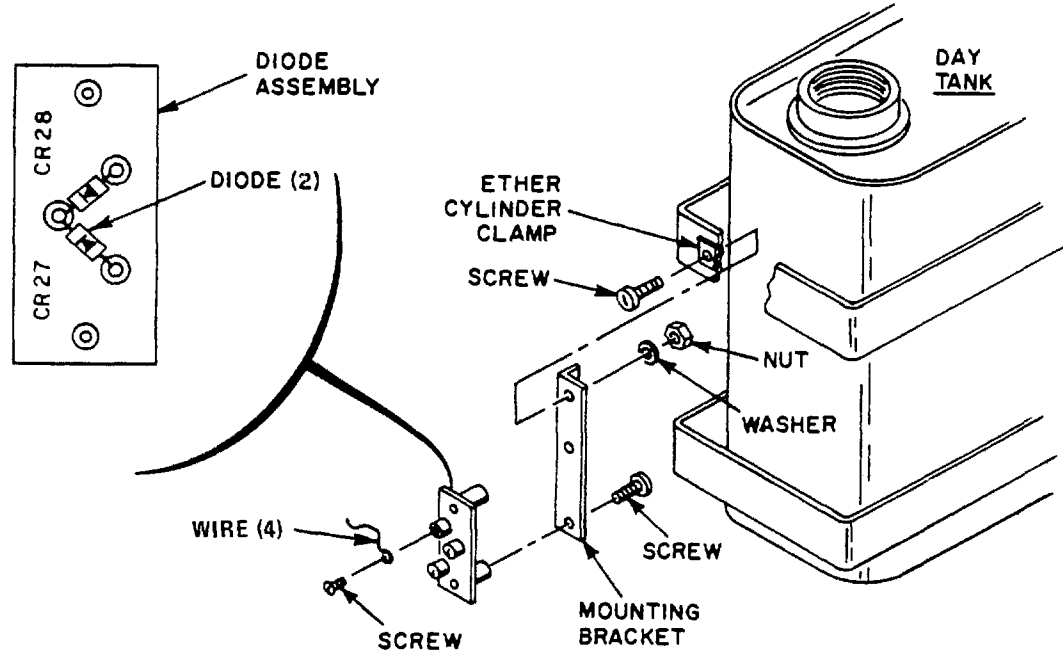

#### REMOVAL

- STEP 1. OPEN ETHER CYLINDER CLAMP AND REMOVE ETHER CYLINDER.
- STEP 2. TAG AND DISCONNECT FOUR WIRES FROM DIODE ASSEMBLY TERMINALS BY REMOVING SCREWS.
- STEP 3. DISCONNECT DIODE ASSEMBLY AND MOUNTING BRACKET FROM DAY TANK BY REMOVING SCREW, NUT, AND WASHER HOLDING RIGHT SIDE OF ETHER CYLINDER CLAMP. REMOVE DIODE ASSEMBLY FROM MOUNTING BRACKET BY REMOVING SCREWS, NUTS, AND WASHERS.
- STEP 4. TO REPLACE DIODES, UNSOLDER DIODES FROM TERMINALS EXERCISING CARE NOT TO APPLY EXCESSIVE HEAT.

#### INSTALLATION

- STEP 1. POSITION DIODE ASSEMBLY ON MOUNTING BRACKET AND SECURE WITH SCREWS. CONNECT ASSEMBLED BRACKET TO DAY TANK AND SECURE WITH SCREW, NUT, AND WASHER.
- STEP 2. CONNECT WIRES TO DIODE ASSEMBLY TERMINALS AND SECURE WITH SCREWS.
- STEP 3. INSTALL ETHER CYLINDER IN ETHER PRIMER (SOLENOID VALVE) MAKING SURE PACKING IS PROPERLY INSTALLED BETWEEN CYLINDER AND PRIMER. TIGHTEN CYLINDER HAND TIGHT. SECURE CYLINDER WITH CLAMP.

Figure 4-9. Radio Interference Suppression Components,  
 Removal and Installation

## Section VIII. MAINTENANCE OF HOUSING

4-20. GENERAL. The housing encloses the top, sides, and ends of the generator set, and provides protection from rain and dirt. Hinged access doors are provided for access to components and are equipped with latches to secure the doors in the closed position. The housing assembly may be removed from the generator set to provide additional access for replacement or overhaul of major components.

4-21. ACCESS DOORS. Remove and replace access doors as follows (see figure 4-10):

a. Removal.

NOTE

Door seals are press-fit into seal retaining channels around each access door. The seals may be removed and replaced without removing the doors from the generator set. See figure 4-11. To remove right front access doors it is necessary to first remove the exhaust muffler (refer to paragraph 4-97).

(1) Open loop and remove retaining rod (1).

WARNING

Drilling operations to remove rivets can create metal chips which may enter the eye. Wearing of goggles is required.

(2) Remove rivet (2) and clip (3) only if damaged or defective.

(3) Remove screw (4) and nut (5) to remove access doors (6). Remove seal (7) only if damaged or defective.

NOTE

Some access doors are equipped with a shutter assembly. Remove shutter assemblies in accordance with step (4).

(4) Remove screw (8) and nut (9) to remove shutter assembly (10).

NOTE

Any side access door may be removed by following steps (1) through (4).

(5) Force loop that secures door holder (11) open and remove holder.

(6) Remove screw (12) and nut (13) to remove access door (14). Remove seal (15) only if damaged or defective.

NOTE

Either upper rear access door may be removed by following steps (5) and (6).

(7) Open loop and remove door holder (16).

(8) Remove screw (17) and nut (18) to remove access door (19). Remove seal (20) only if damaged or defective.

NOTE

Either lower rear access door may be removed by following steps (7) and (8).

(9) Remove screws (21), washers (22 and 23), and nuts (24) to remove access door (25) and battery access frame (89). Remove seal (26) only if damaged or defective.



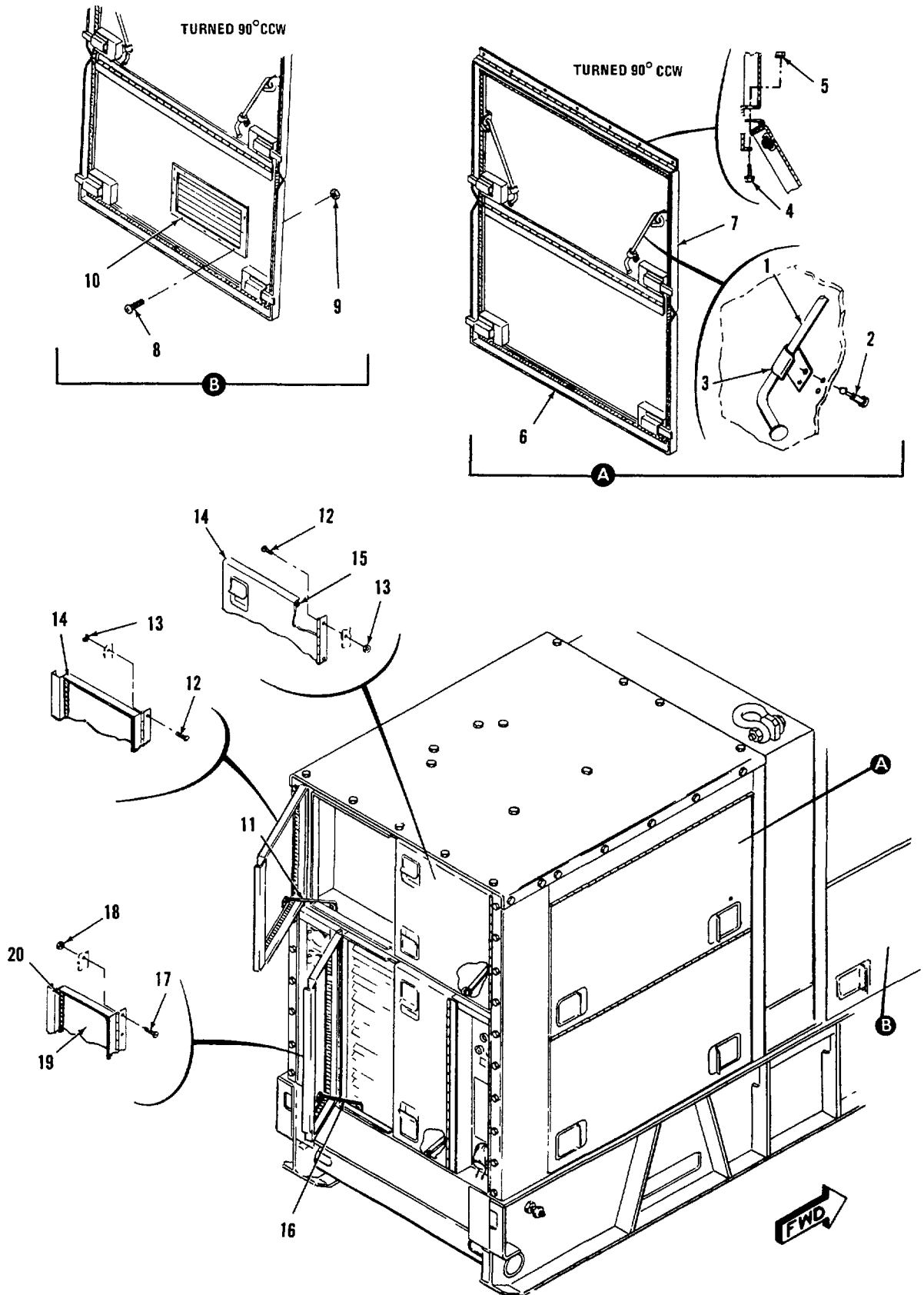

Figure 4-10. Housing, Exploded View (Sheet 1 of 2)

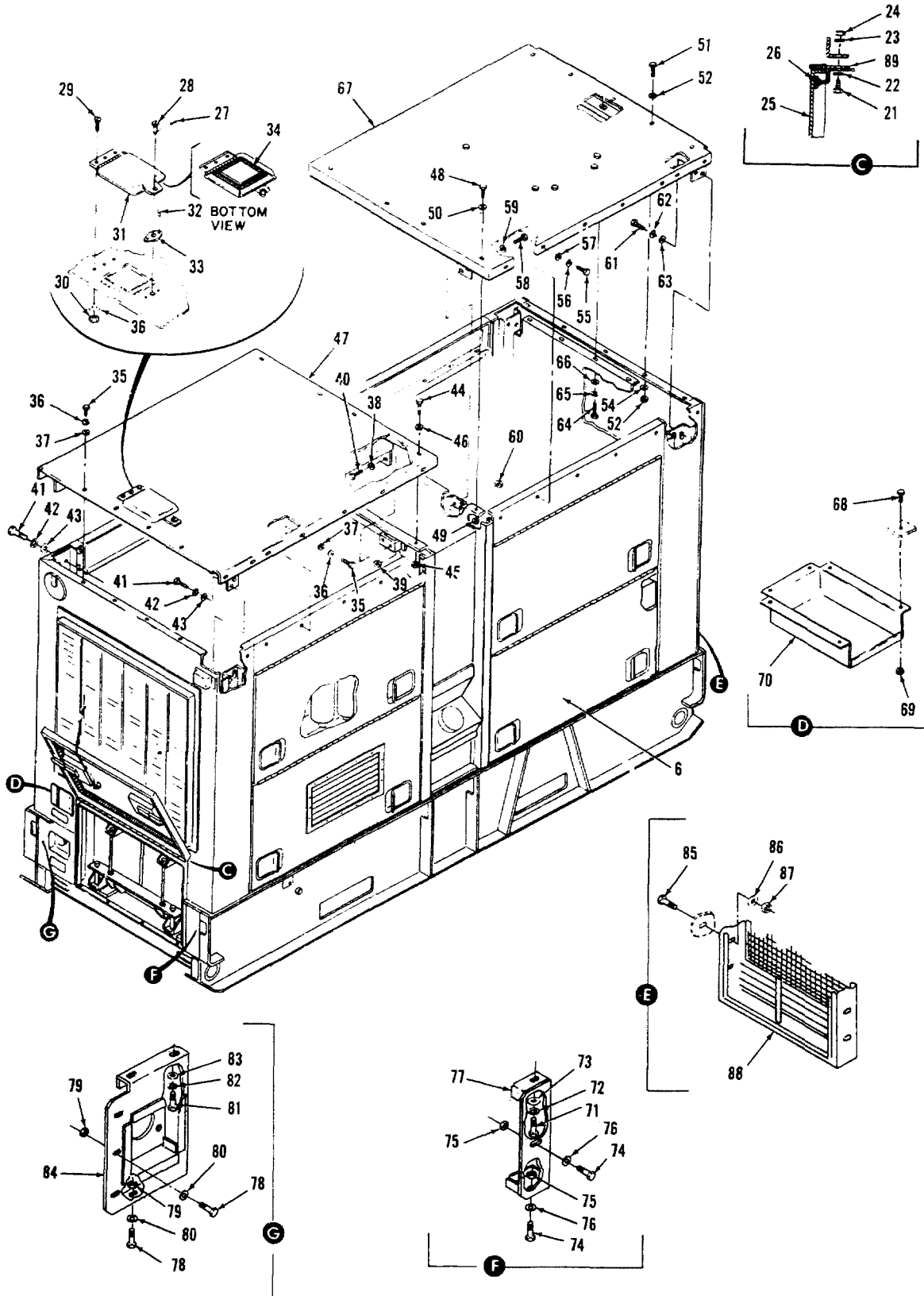

Figure 4-10. Housing, Exploded View (Sheet 2 of 2)

LEGEND FOR FIGURE 4-10

- |                              |                          |
|------------------------------|--------------------------|
| 1. RETAINING ROD             | 47. FRONT COVER          |
| 2. RIVET                     | 48. SCREW                |
| 3. CLIP                      | 49. NUT                  |
| 4. SCREW                     | 50. WASHER               |
| 5. NUT                       | 51. SCREW                |
| 6. ACCESS DOOR               | 52. NUT                  |
| 7. SEAL                      | 53. WASHER               |
| 8. SCREW                     | 54. WASHER               |
| 9. NUT                       | 55. SCREW                |
| 10. SHUTTER ASSEMBLY         | 56. LOCKWASHER           |
| 11. DOOR HOLDER              | 57. WASHER               |
| 12. SCREW                    | 58. SCREW                |
| 13. NUT                      | 59. NUT                  |
| 14. ACCESS DOOR              | 60. WASHER               |
| 15. SEAL                     | 61. SCREW                |
| 16. DOOR HOLDER              | 62. LOCKWASHER           |
| 17. SCREW                    | 63. WASHER               |
| 18. NUT                      | 64. SCREW                |
| 19. ACCESS DOOR              | 65. LOCKWASHER           |
| 20. SEAL                     | 66. WASHER               |
| 21. SCREW                    | 67. REAR COVER           |
| 22. WASHER                   | 68. SCREW                |
| 23. WASHER                   | 69. NUT                  |
| 24. NUT                      | 70. STORAGE BOX          |
| 25. ACCESS DOOR              | 71. SCREW                |
| 26. SEAL                     | 72. WASHER               |
| 27. PIN                      | 73. WASHER               |
| 28. STUD                     | 74. SCREW                |
| 29. SCREW                    | 75. NUT                  |
| 30. NUT                      | 76. WASHER               |
| 31. RADIATOR CAP ACCESS DOOR | 77. PANEL                |
| 32. RIVET                    | 78. SCREW                |
| 33. RECEPTACLE               | 79. NUT                  |
| 34. SEAL                     | 80. WASHER               |
| 35. SCREW                    | 81. SCREW                |
| 36. LOCKWASHER               | 82. WASHER               |
| 37. WASHER                   | 83. WASHER               |
| 38. SCREW                    | 84. PANEL                |
| 39. NUT                      | 85. SCREW                |
| 40. WASHER                   | 86. WASHER               |
| 41. SCREW                    | 87. NUT                  |
| 42. LOCKWASHER               | 88. AIR INTAKE LOUVERS   |
| 43. WASHER                   | 89. BATTERY ACCESS FRAME |
| 44. SCREW                    |                          |
| 45. NUT                      |                          |
| 46. WASHER                   |                          |

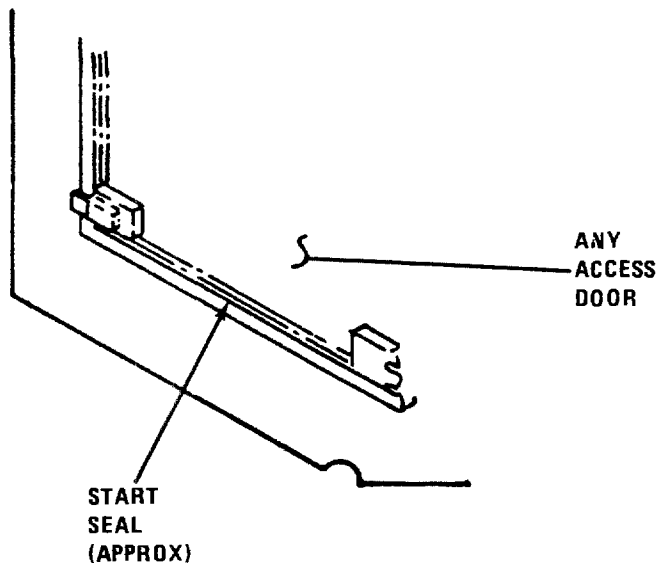

Figure 4-11. Installation of Door Seals

**WARNING**

Drilling operations to remove rivets can create metal chips which may enter the eye. Wearing of goggles is required.

(10) Remove pin (27) and stud (28). Remove screws (29) and nuts (30) to remove radiator cap access door (31). Remove rivet (32), receptacle (33), and seal (34) only if damaged or defective.

b. Replacement.

(1) Install rivet (32), receptacle (33), and seal (34), if removed. Install radiator cap access door (31) and secure with screw (29) and nut (30). Install stud (28) and pin (27).

(2) Install new seal (26) if removed. Install access door (25) and secure with screw (21), washers (22 and 23), and nut (24). Install battery access frame (89).

(3) Install new seal (20) if removed. Install access door (19) and secure with screws (17) and nuts (18). Install door holder (16).

**NOTE**

Either lower rear access door may be replaced by following step (3).

(4) Install new seal (15) if removed. Install access door (14) and secure with screws (12) and nuts (13). Install door holder (11).

**NOTE**

Either upper rear access door may be replaced by following step (4).

**NOTE**

Some access doors are equipped with a shutter assembly, which locks in an open or closed position. Replace shutter assemblies in accordance with step (5).

(5) Install shutter assembly (10) and secure with screws (8) and nuts (9).

(6) Install new seal (7) if removed. Install access doors (6) and secure with screws and nuts (5).

(7) Install new clip (3) and rivet (2), if removed. Install retaining rod (1).

4-22. COVERS. Remove and replace covers as follows (see figure 4-10):

a. Removal.

(1) Remove screws (35), lockwashers (36), and washers (37).

(2) Remove screws (38), nuts (39), and washers (40).

(3) Remove screws (41), lockwashers (42), and washers (43).

(4) Remove screws (44), nuts (45), and washers (46).

NOTE

Unhook muffler clamp from cover bracket (see figure 4-51, items 13 and 18).

(5) Remove front cover (47).

(6) Remove screws (48), nuts (49), and washers (50).

(7) Remove screws (51), nuts (52), and washers (53 and 54).

(8) Remove screws (55), lockwashers (56), and washers (57).

(9) Remove screws (58), nuts (59), and washers (60).

(10) Remove screws (61), lockwashers (62), and washers (63).

(11) Remove screws (64), lockwashers (65), and washers (66). Remove rear cover (67).

(12) Remove screws (68) and nuts (69) to remove storage box (70).

b. Replacement.

(1) Install storage box (70) and secure with screws (68) and nuts (69).

(2) Install rear cover (67). Install screws (64), lockwashers (65), and washers (66).

(3) Install screws (61), lockwashers (62), and washers (63).

(4) Install screws (58), nuts (59), and washers (60).

(5) Install screws (55), lockwashers (56), and washers (57).

(6) Install screws (51), nuts (52), and washers (53 and 54).

(7) Install screws (48), nuts (49), and washers (50).

(8) Install front cover (47).

NOTE

Hook muffler clamp to front cover (see figure 4-50, items 13 and 18).

(9) Install screws (44), nuts (45), and washers (46).

(10) Install screws (41), lockwashers (42), and washers (43).

(11) Install screws (38), nuts (39), and washers (40).

(12) Install screws (35), lockwashers (36), and washers (37).

4-23. PANELS. Remove and replace panels as follows (see figure 4-10):

NOTE

The panels are located to the left and right of the battery compartment.

a. Removal.

(1) Remove screw (71) and washers (72 and 73).

(2) Remove screws (74), nuts (75), and washers (76). Remove panel (77).

(3) Remove slave receptacle in accordance with paragraph 4-29b.

(4) Remove screws (78), nuts (79), and washers (80).

(5) Remove screw (81) and washers (82 and 83). Remove panel (84).

b. Replacement.

(1) Install panel (84) with screws (81) and washers (82 and 83).

(2) Install screws (78), nuts (79), and washers (80).

(3) Install slave receptacle in accordance with paragraph 4-29b.

(4) Install panel (77).  
 Install screws (74), nuts (75), and washers (76).  
 (5) Install screw (71) and washers (72 and 73).

4-24. RADIATOR GRILLE. Remove and replace radiator grille as follows:

a. Removal. Remove radiator grille in accordance with paragraph 4-100d.

b. Replacement. Replace radiator grille in accordance with paragraph 4-100d.

4-25. TOOL BOX. Remove and replace tool box as follows (see figure 4-12):

a. Removal.

(1) The tool box is located at the base of the generator's rear. Remove bolts (1), lockwashers (2), and washers (3).

(2) Remove screws (4) and lockwashers (5).

(3) Remove screws (6), nuts (7), and washers (8 and 9).

(4) Remove screws (10) and washers (11 and 12).

(5) Remove screws (13) and washers (14 and 15). Remove tool box (16).

(6) Open tool box access door (17). Remove screws (18), lockwashers (19), and nuts (20) to remove filler panel (21).

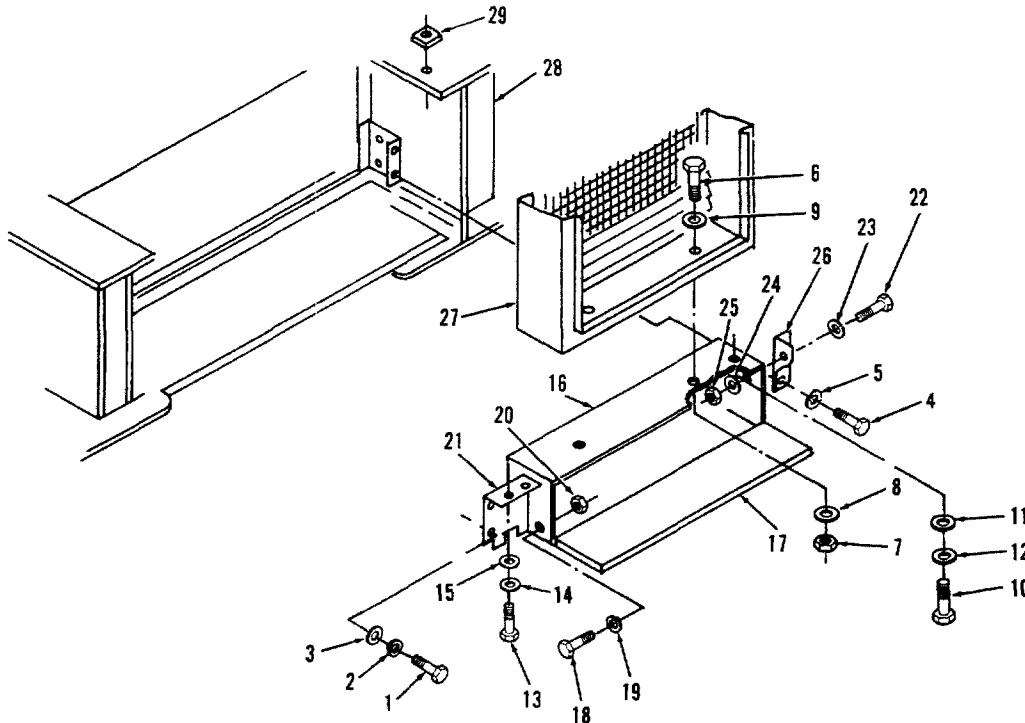

- |               |            |                          |                     |
|---------------|------------|--------------------------|---------------------|
| 1. BOLT       | 8. WASHER  | 15. WASHER               | 22. SCREW           |
| 2. LOCKWASHER | 9. WASHER  | 16. TOOL BOX             | 23. WASHER          |
| 3. WASHER     | 10. SCREW  | 17. TOOL BOX ACCESS DOOR | 24. WASHER          |
| 4. SCREW      | 11. WASHER | 18. SCREW                | 25. NUT             |
| 5. LOCKWASHER | 12. WASHER | 19. LOCKWASHER           | 26. SUPPORT BRACKET |
| 6. SCREW      | 13. SCREW  | 20. NUT                  | 27. REAR HOUSING    |
| 7. NUT        | 14. WASHER | 21. FILLER PANEL         | 28. SKID BASE       |
|               |            |                          | 29. NUT PLATE       |

Figure 4-12. Tool Box, Removal and Replacement

(7) Remove screws (22), washers (23 and 24), and nuts (25) to remove support bracket (26).

b. Replacement.

(1) Install support bracket (26) on the tool box (16) and secure with screws (22), washers (23 and 24), and nuts (25).

(2) Open tool box access door (17). Install screws (18), lockwashers (19), and nuts (20) to secure filler panel (21).

(3) Install the tool box (16) and secure with screws (13) and washers (14 and 15).

(4) Install screws (10) and washers (11 and 12).

(5) Install screws (6), nuts (7), and washers (8 and 9).

(6) Install screws (4) and lockwashers (5).

(7) Install bolts (1), lockwashers (2), and washers (3).

4-26. AIR INTAKE LOUVERS. Remove and replace air intake louvers as follows (see figure 4-10).

a. Removal. Remove screws (85), washers (86), and nuts (87) to remove air intake louvers (88).

b. Replacement. Install air intake louvers (88) and secure with screws (85), washers (86), and nuts (87).

## Section IX. MAINTENANCE OF DC ELECTRICAL AND CONTROL SYSTEM

4-27. GENERAL. The primary function of the DC electrical and control system is to start, stop, and monitor the diesel engine under a variety of operating conditions. Physically, the various components that comprise the DC electrical and control system (relays, switches, solenoids, indicators, etc.) are located at various points throughout the generator set. The theory of operation for this system (during various modes of operation) is presented in paragraph 4-28 and referenced to F0-5, the generator set DC schematic diagram. Paragraphs 4-28 through 4-39 provide organizational maintenance procedures for the DC electrical and control system.

4-28. THEORY OF OPERATION. This discussion, wherever possible, corresponds to the actual operation of the generator set.

### NOTE

When the generator set is first turned on, 24 V dc is applied to the entire DC electrical and

control system activating solenoids, pumps, and relays. All of these actions occur either simultaneously or within a very short time of each other. When reading the following circuit descriptions be aware of these relationships.

a. Engine Starting. When the START-STOP-RUN switch is toggled to the START position, four actions occur: cranking relay K3 energizes, both the engine and day tank solenoids activate, fuel pumps B2 and B3 start operating, and stop-run relay K1 energizes. When cranking relay K3 energizes, its contacts close and 24 V dc is applied to and activates the start solenoid (mounted on starter motor B1). As a result, B1 cranks the diesel engine, turning it over at an approximate rate of 300 rpm. Fuel (permitted to flow when the day tank solenoid activates) travels from the day tank to the fuel injection pump. The injection pump pressurizes the fuel and sends it through a valve (opened when fuel shutdown solenoid L1 activates) to the fuel injectors. The

fuel is then atomized and injected into the engine's combustion chambers where it is combined and compressed with intake air to a point at which the heat of this compression causes combustion. At this point, the engine starts and cranking stops. Fuel pumps B2 and B3 force from the fuel set tank to the day tank replenishing the fuel used to operate the engine. Engine operation is maintained by keeping L1 and stop-run relay K1 energized. This is accomplished by applying the 24 V dc from S2 through a protective interlock circuit: the normally open contacts of K1; the normally closed contacts of overvoltage relay K2; the contacts of oil pressure switch OP (which close when oil pressure is sufficient); the contacts of coolant temperature switch WT; normally closed contacts of fuel level relay K8; and overspeed switch S9-3.

b. Starter Motor Protection. When the engine attains a speed in excess of 600 rpm, the contacts of speed switch S9-1 open and cranking relay K3 deenergizes. With K3 deenergized, its contacts open and 24 V dc is disconnected from the start solenoid. Consequently, the start solenoid deactivates and starter motor B1 stops cranking and mechanically disengages from the engine flywheel.

c. Engine Stopping. To stop the engine, the START-STOP-RUN switch S2 is set to STOP and 24 V dc is disconnected from the engine fuel shutdown solenoid L1. With L1 deactivated, the valve controlled by L1 snaps shut and cuts off the flow of fuel to the engine. With no fuel supply, the engine quickly shuts down.

d. Engine Protection. Normal operation will continue as long as no fault condition occurs which might cause damage directly to the engine or to the generator if the set were to continue operating. Once such a condition does occur, however, engine operation is automatically brought to a halt by shutting off the fuel supply to the engine by deactivating fuel

shutdown solenoid L1. L1 will deactivate if: (1) generator output voltage becomes excessive, (2) lubricating oil pressure is insufficient, (3) coolant temperature becomes excessive, (4) fuel level is near empty, and (5) engine speed becomes excessive.

(1) If engine speed becomes excessive or voltage regulator A10 malfunctions, the generator output voltage might rise to a level harmful to either the load, the generator, or the engine controls. To prevent this, overvoltage relay K2 is connected across the generator's output. If an overvoltage condition (156 volts or greater) is sensed by K2, it energizes, and its contacts, which are connected in series with fuel shutdown solenoid L1 and the 24 V dc supply, open to deactivate L1.

(2) If lubricating oil pressure falls below 15 +/-3 psi (approximately 103 kPa), the contacts of oil pressure switch OP open and remove power from fuel solenoid L1, thereby shutting down the engine. Because this switch is normally open, the operator, when first starting the engine, must allow the reading on the OIL PRESSURE gage to exceed 15 psi (approximately 103 kPa) prior to releasing the START-STOP-RUN switch S2.

(3) If the engine coolant rises above 222 +/-3°F (106 +0.7°C) engine damage may occur. Water temperature switch WT, mounted in the engine block, senses coolant temperature and opens when this temperature becomes excessive. Connected in series with L1, this switch deactivates the fuel solenoid when it opens.

(4) In addition to the fact that engine damage may occur, if the engine ran completely out of fuel, trying to restart the engine with a new supply of fuel would require an elaborate and time-consuming "bleeding" procedure. To avoid this, fuel level switch FL-1 senses when



there is only enough fuel for 1 more minute of engine operation and shuts the engine down by deenergizing relay K8 (K8 contacts disconnect 24 V dc from fuel shutdown solenoid L1 when they open).

(5) If engine speed increases to a point where damage may occur, overspeed switch S9-3 (set to operate at approximately 2450 rpm) opens, deactivating fuel shutdown solenoid L1 by removing 24 V dc from the solenoid.

e. Engine Fault Indicators. If an engine fault occurs, the engine will shut down and one of several indicator lamps (mounted on the FAULT INDICATOR panel) will light. To ensure proper operation of these fault indicators, a means whereby the lamps may be tested is provided. Since all of these circuits act in a similar manner, only the components of the low oil pressure protective circuit from R1 and R11 to the bottom of the fault indicator panel schematic diagram (figure 1-5) will be described.

When the generator set is first turned on, oil pressure switch OP contacts are closed simulating what is essentially a fault condition. As a result, current from the 24 V dc supply takes the following path: through contacts of TEST OR RESET switch S1 (normally closed), switch OP, resistors R1 and R11 (causing a voltage drop across R11), and the upper set of S1 contacts back to the 24 V dc return. The voltage drop across R11 (connected across the cathode and gate of SCR1) turns on the silicon-controlled rectifier SCR1. The current flow from the 24 V dc supply now branches off into a second path: through the switch S1 contacts, indicator lamp DS1 (causing it to light), the anode-cathode junction of SCR1, and back to the 24 V dc return through the upper set of S1 contacts. A third current path is also established: through relay K1 (energizing K1), diode CR1, SCR1, and back to the 24 V dc return. With K1 energized, its contacts open, breaking

the original current path consisting of switch OP, and resistors R1 and R11. Although the voltage drop across R11 is no longer present, SCR1 continues to conduct, keeping DS1 lit and K1 energized.

#### NOTE

A silicon-controlled rectifier (SCR) conducts when its gate voltage reaches a certain value. However, if this gate voltage is removed, the SCR will continue to conduct. The SCR will stop conducting only when the voltage across its cathode-anode is removed.

When testing or resetting the fault indicator circuits, operate spring-loaded switch S1 to its opposite position. This action opens the 24 V dc return, removing 24 V dc from SCR1, causing it to "turn off" (stop conducting). With SCR1 off, the current path to relay K1 is broken causing it to deenergize. The indicator lamp DS1 either lights (if testing) or stays lit (if resetting) by a second path established through diode CR1, lamp DS1, and the upper set of S1 contacts.

f. Engine Operation. Once the engine is running, it is only necessary to monitor various operating parameters, to vary engine speed as required to establish generator output frequency, and to maintain a supply of fuel. However, if the engine generator set shuts down due to a malfunction, it may be desirable (during battle conditions) to override the malfunction (if possible) and allow for the continued operation of the generator set.

(1) Engine Speed. Engine speed is controlled by adjusting the manual engine speed control. Repositioning this control affects the setting of the governor's throttle, which increases or decreases the supply of fuel to the fuel injectors.

(2) Engine Monitoring.

Four gages, M1 through M4, are located on the control cubicle. These gages monitor the following engine-related operating conditions: oil pressure, coolant temperature, fuel level, and the rate of battery charging. Transmitters MT1 through MT3, which are connected to gages M1 through M3, are actually variable resistors whose resistance changes as a function of the parameter being monitored. Once the engine starts, all of these circuits are activated through the normally open contacts of relay K1. The rate at which the batteries are charged or discharged is monitored by meter M4 which is connected in series with the 24 V dc line. A calibrated meter shunt, R13, limits the current flowing in the meter to a safe level. M5 is an elapsed time meter which is energized by K1 contacts only when the engine is running.

(3) Fuel Transfer.

Prolonged operation of the engine generator set is obtained by the use of additional fuel tanks. The transfer of fuel from either the set tank or an auxiliary tank to the day tank is controlled by fuel level switches FL-1 and FL-2 mounted in the day tank. FL-2 senses when day tank fuel falls below a certain level and closes to energize the day tank fuel solenoid. When this solenoid activates, the valve it controls opens to permit the transfer of fuel from either the set or auxiliary tank to the day tank. When the level of fuel reaches certain level, FL-2 opens and the day tank solenoid deactivates, shutting off the flow of fuel oil to the day tank. If either the fuel or auxiliary tank runs out of fuel, however, the fuel level in the day tank will drop to a point very close to empty. When this happens, FL-1 (also mounted in the day tank) opens and deenergizes fuel level relay K8. As a result, the contacts of K8 (part of the engine protection circuit -- see subparagraph 4-28d), open and

deactivate fuel solenoid L1. As previously described, this action causes the engine to shut down and the NO FUEL indicator to light.

(4) Battle Short. During battle conditions, the requirement of continued operation may override the need to protect the generator set. When BATTLE SHORT switch S7 is set to ON, the engine protection circuits (with the exception of overspeed switch S9-3) are bypassed, and fuel shutdown solenoid L1 remains activated.

g. Ether Starting. As an aid to cold weather starting provisions are made to inject ether into the engine air intake manifold only while the engine is being cranked. With START-RUN-STOP switch S2 held in the START position, the application of this highly volatile fluid is then controlled by the ether solenoid and ENGINE PRIMER switch S1. Operating spring-loaded switch S1 to the ON position activates the ether solenoid which causes a measured amount of ether to be loaded into the ether aid device. Upon release of S1, this measured amount of ether is forcefully injected into the air intake manifold.

h. Miscellaneous. The following subparagraphs briefly describe those DC circuits not directly related to engine operation.

(1) Battery Charging Circuit. DC Alternator G2 generates a dc voltage when the engine is operating. This voltage, applied through a regulator (part of G2) keeps both batteries in a fully charged state. The 24-volt field voltage for G2 is coupled through the contacts of relay K1 and steering diode CR6. Consequently, the G2 field disconnects when the engine is in the process of shutting down, thereby preventing possible alternator damage.

(2) Panel Lights. Panel lights DS1, DS2, and DS3 are controlled by PANEL LIGHT switch S4.

(3) Field Flash Circuit. The field flash circuit momentarily

applies 24 V dc to the field of generator G1, thereby restoring the field magnets to their full strength. When engine speed reaches 600 rpm (during start time), normally open speed switch S9-1 closes. With S9-1 closed, field flash relay K5 energizes and 24 V dc is applied through closed contacts of K5 to the exciter field. After 2 or 3 seconds, K5 deenergizes (because of its design) and the field flash circuit disconnects. A second set of K5 contacts, which also quickly open and close, is used to reset the oil pressure fault indicator circuit. The oil pressure fault indicator circuit activates because, initially, oil pressure is at zero.

4-29. BATTERIES AND RELATED COMPONENTS. The generator set is equipped with two 12-volt, 100 ampere-hour batteries that are mounted on a rollout tray below the radiator. The batteries are connected in series to supply 24 V dc for starting of the generator set and operation of direct current components. Two slave receptacles, connected in parallel, permit easy connection to the batteries to supply or obtain battery power.

a. Batteries and Rollout Tray.  
(1) Battery Test.

Batteries should be permitted to stand a minimum of 30 minutes after operation of generator set prior to testing. Test batteries using a battery electrolyte solution tester (hydrometer) as follows:

NOTE

Do not add water to batteries prior to testing.

(a) Remove quick release pins (figure 4-13), and rollout battery tray, to gain access to batteries and remove battery filler caps.

Electrolyte temperature must be between 70° and 90°F (21° and 32°C) during test or be temperature corrected.

(b) Test electrolyte specific gravity of each battery cell. A fully charged battery should have specific gravity of 1.280 +/-0.005. If battery electrolyte specific gravity is less than 1.250, battery should be charged. Replace battery that will not hold a charge.

CAUTION

Do not expose a battery to temperatures below 0°F (-17.6°C) if specific gravity of electrolyte is less than 1.250.

(2) Removal and Disassembly. Remove and disassemble batteries and rollout tray as illustrated in figure 4-13, observing the following:

(a) Remove negative battery cables first.  
(b) Sequence of removal shall be as follows: remove battery cables, retainers, batteries, stop angle, and rollout tray.

(3) Cleaning and Inspection.

WARNING

Dry cleaning solvent, P-D-680, Type II, is flammable and moderately toxic to the skin, eyes, and respiratory tract. Skin, eye, and respiratory protection is required.

(a) Clean parts with cleaning solvent (P-D-680, Type II) and dry thoroughly.

(b) Clean battery posts and cable ends (internal surfaces) with a wire brush.

(c) Inspect for cracks, breaks, and other damage. Replace defective parts.

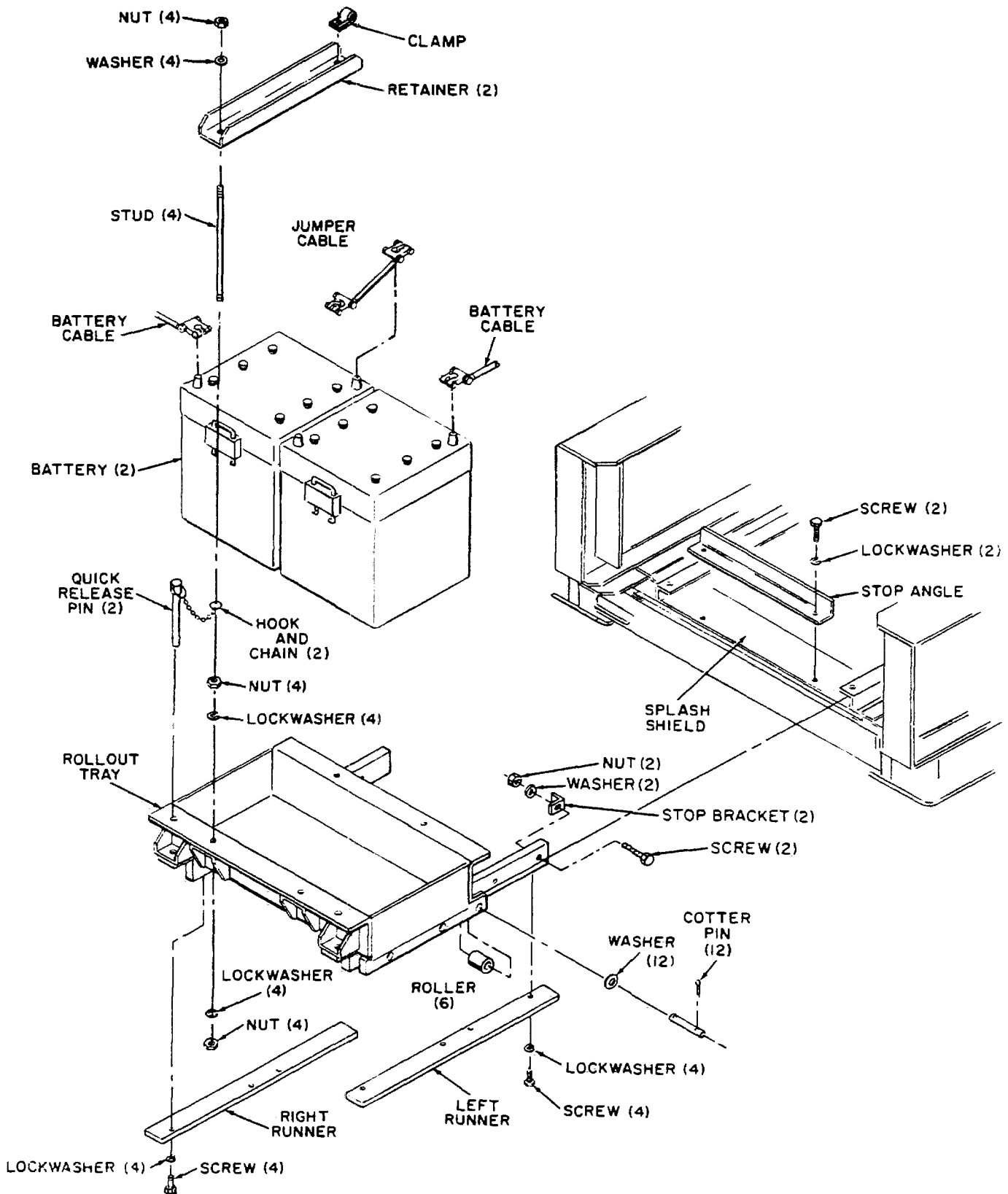

Figure 4-13. Batteries and Rollout Tray, Exploded View

WARNING

Paint is flammable and moderately toxic. Avoid eye and skin contact or breathing of vapors. Skin, eye, and respiratory protection is required.

(d) Inspect for damaged acid-resistant paint. Repair damaged paint surfaces by applying acid-resistant black lacquer conforming to Federal Specification TT-L-54, Type I.

(4) Reassembly and Installation. Reassemble and install batteries and rollout tray as illustrated in figure 4-13, observing the following:

(a) Apply thin film of grease conforming to Military Specification MIL-G-10924 to roller shafts prior to reassembly.

(b) Sequence of installation should be as follows: rollout tray, stop angle, batteries, retainers, and battery cables. When installing batteries, place batteries in rollout tray so that positive posts are toward front of generator set. Connect negative battery cable to battery last. Refer to figure 4-14 and check battery cables for proper connection.

(c) After jumper and battery cables are installed on batteries, coat battery posts and cable ends with grease to prevent corrosion.

b. Battery Cables and Slave Receptacles.

(1) Removal. Remove battery cables and slave receptacles as illustrated in figure 4-14, removing negative cables first.

(2) Cleaning and Inspection.

(a) Clean cable ends (internal surfaces) with a wire brush.

(b) Inspect cable insulation for corrosion and deterioration.

(c) Inspect slave receptacles for bent or broken pins and for cracked insulation. Replace defective parts.

(3) Installation. Install battery cables and slave receptacles as illustrated in figure 4-14, observing the following:

(a) Install slave receptacle SR1 with keyway up and SR2 with small pin up.

(b) Connect negative cables last.

(c) Coat battery posts and cable ends with grease to prevent corrosion after installation.

4-30. ALTERNATOR AND FAN BELTS. The alternator is driven by a single belt which is powered by the fan pulley.

a. Removal. To remove alternator and fan belts, refer to figure 4-15 and proceed as follows:

(1) Remove fan guards, refer to paragraph 4-106.

(2) Remove alternator guard bolts and washers (figure 4-15). Loosen alternator bolt and pivot alternator fan guard away from alternator.

(3) Loosen adjusting rod bolt. Back off lower adjusting rod nut until alternator belt can be removed from alternator.

(4) Loosen fan bracket bolts. Rotate fan bracket adjusting bolt and lower fan bracket until it bottoms and then remove adjusting bolt.

(5) Open battery compartment access door, remove two quick release pins, and pull out batteries and rollout tray.

CAUTION

Exercise care to prevent damaging radiator with fan during removal.

(6) Support weight of fan assembly and remove fan bracket bolts, washer, and lockwashers.

(7) Move fan bracket away from engine until it can be rotated. Rotate bracket 180 degrees so that short end is even with top of fan pulley. Remove alternator and fan belts from fan pulley and from fan bracket. Remove belts from alternator and crankshaft pulley.

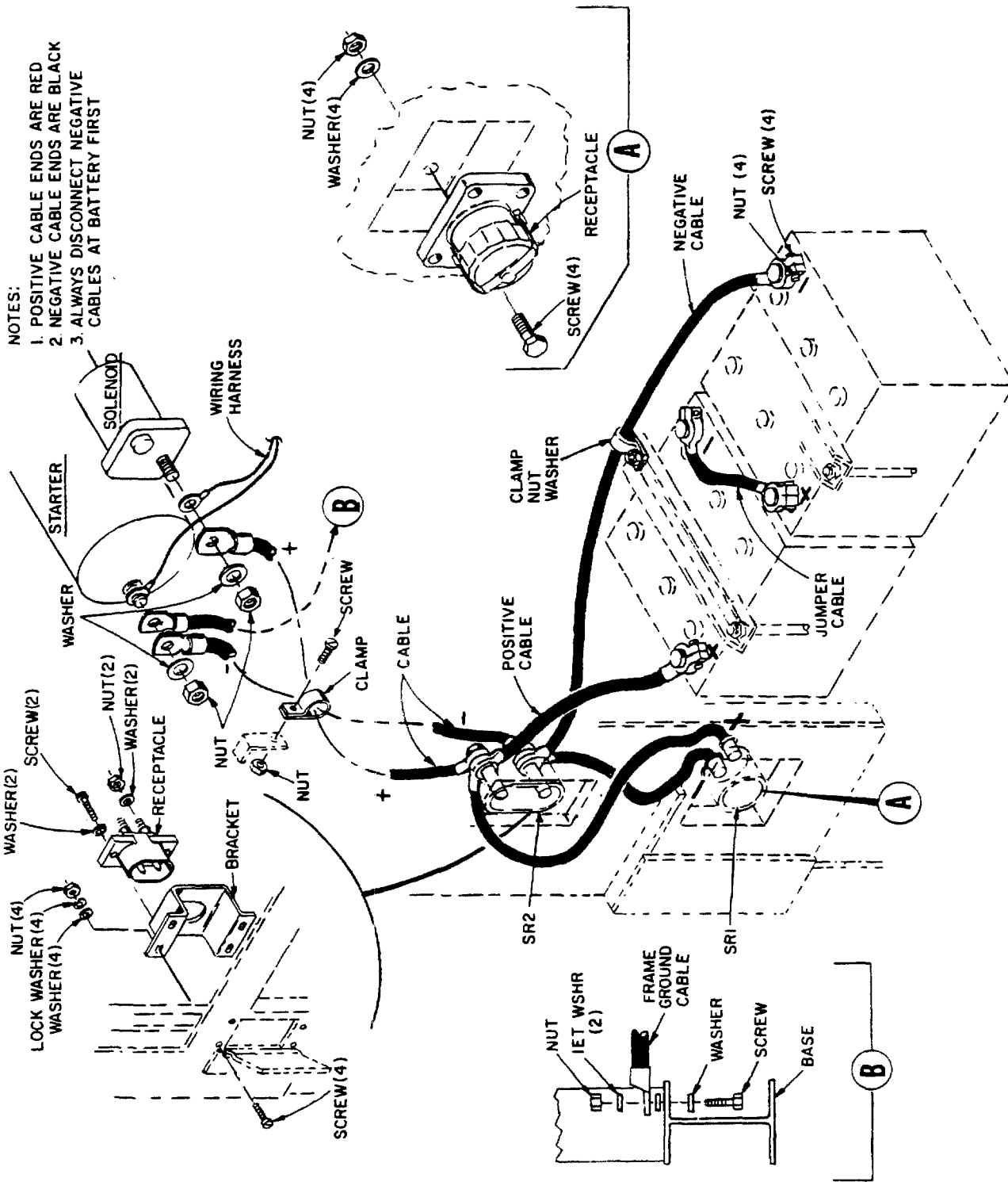

Figure 4-14. Battery Cables and Slave Receptacles, Removal and Installation

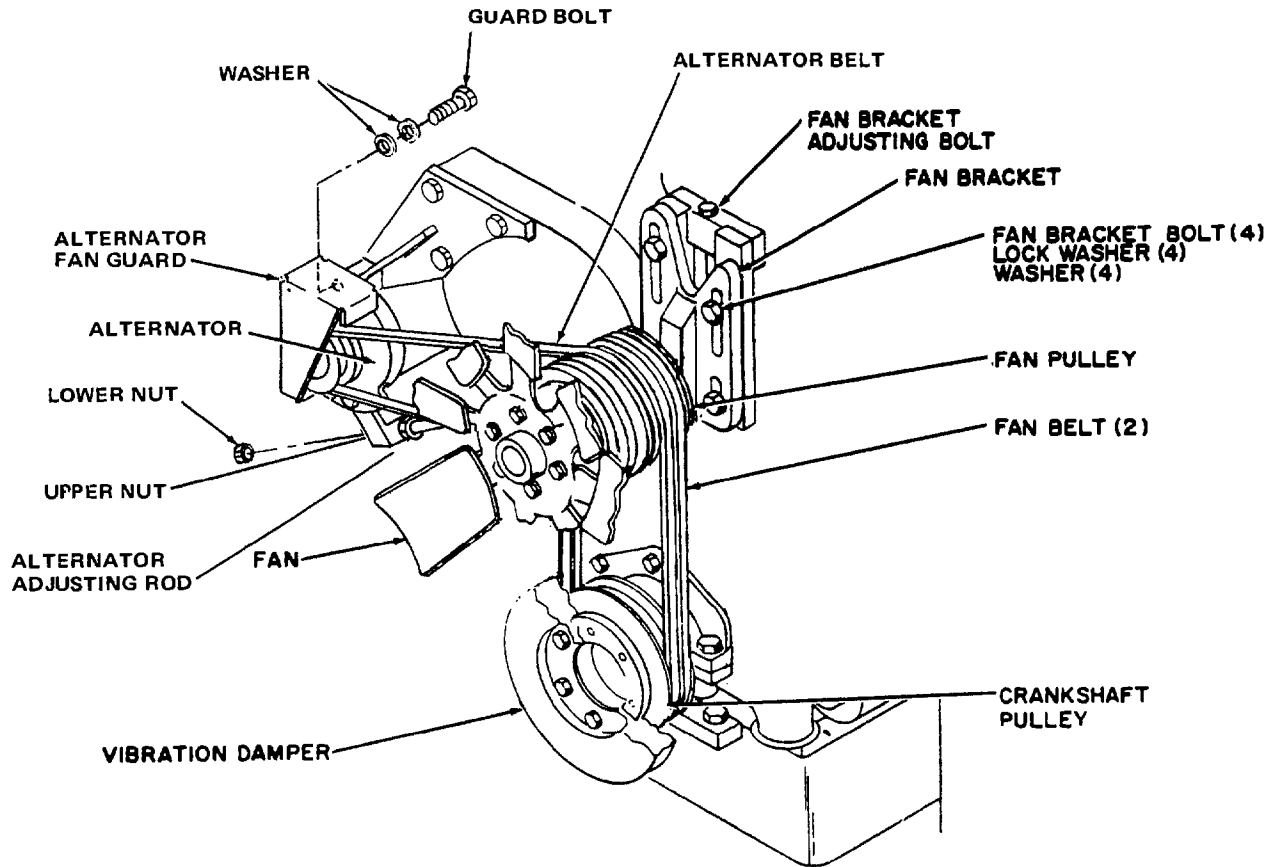

Figure 4-15. Alternator and Fan Belts, Removal and Installation

b. Cleaning and Inspection.

WARNING

Dry cleaning solvent, P-D-680, Type II, is flammable and moderately toxic to the skin, eyes, and respiratory tract. Skin, eye, and respiratory protection is required.

- (1) Clean pulleys with cleaning solvent (P-D-680, Type II) and dry thoroughly.
- (2) Inspect pulleys and fan mounting bracket for breaks, and other damage.
- (3) Inspect belts for deterioration, cuts, and tears.

NOTE

Fan belts are a matched set and shall be replaced as a set.

- (4) Replace defective parts.

c. Installation. To install alternator and belts, refer to figure 4-15, and proceed as follows:

- (1) Position fan belts on crankshaft pulley.

NOTE

Fan belts should be positioned in two rear pulley grooves and alternator belt in groove forward of the fan belts.

(2) With short end of fan mounting bracket even with top of fan pulley, position fan belts and then alternator belt on fan pulley from fan bracket end. Alternator belt should be in first pulley groove forward of the fan belts.

(3) Rotate fan bracket to normal mounting position and secure bracket to engine with fan bracket bolts, washers, and lockwashers.

(4) Install fan bracket adjusting bolt.

(5) Tighten fan bracket adjusting bolt until fan belts are at proper tension. (Refer to figure 4-56.)

(6) With fan belt at proper tension, tighten fan bracket bolts.

(7) Tighten lower adjusting rod nut until alternator belt tension is between 9/16 to 13/16 inches (15 to 20 mm) with a 25 pound (10 kg) force applied midway between driver and driven pulley.

(8) Return alternator fan guard to its original position and bolt in place.

(9) Install fan guards that were removed as part of step a(1). (Refer to paragraph 4-106.)

4-31. BATTERY CHARGING ALTERNATOR. The alternator is a 24 V dc, negative ground system incorporating a voltage regulator and voltage protector. It is driven by the fan pulley via the alternator drive belt. The alternator provides power for charging the batteries and operation of direct current components of the generator set.

a. Output Test and Adjustment.

(1) Equipment Required.

(a) Carbon pile (0 to 500 ampere load capacity).

(b) Ammeter (0 to 50 ampere range).

(c) DC voltmeter (0 to 50 volt range).

(d) Heavy duty (50 amperes) single-pole, single-throw knife switch (S1).

(e) Jumper 12 inches long (300 mm), No. 8 wire with two alligator clips.

(2) Equipment Setup.

(a) Remove fuse from rear of alternator (refer to figure 4-17).

(b) Remove rear cover from alternator.

(c) Connect test equipment to alternator as shown in figure 4-16.

(3) Test and Adjustment Procedure.

(a) Set switch S1 of test setup to off, start generator set, and run at rated speed.

(b) Set switch S1 to on and adjust carbon pile for a reading of 30 amperes on the DC ammeter.

(c) Set adjustment screw at rear of alternator for a reading of 24 +/-2 volts on the DC voltmeter. A clockwise rotation of adjustment screw increases alternator output, counterclockwise rotation decreases output.

(d) If proper voltage and amperage reading are not obtained, open switch S1 and shut down engine. Check alternator belt deflection, refer to paragraph 4-30. Adjust belt if necessary, repeat steps (a) through (d).

(e) Open switch S1. Shut down engine. Remove test equipment from alternator and install rear cover and fuse.

(f) Replace alternator if specified voltage and current output can not be obtained.

b. Removal. Remove alternator and mounting group as illustrated in figure 4-17, after removing alternator belt from alternator (refer to paragraph 4-30a).

c. Cleaning and Inspection.

(1) Clean alternator with a clean, dry cloth.



**WARNING**

All cleaning compounds that meet MIL-C-87937 may be toxic. Avoid prolonged or repeated breathing of vapor or contact with skin. Avoid any contact with eyes. Safety glasses and protective gloves are required. Wash hands after use. Refer to applicable MSDS for additional information.

**NOTE**

MIL-C-87937, Types II and IV cleaners must be diluted with water before use. Type III cleaners can be used full

strength or diluted. All MIL-C-87937 products must be rinsed off after cleaning. The cleaning solutions may be more effective if heated. Follow manufacturer's instructions and cautions for specific product used.

(2) Clean other parts using MIL-C-87937 as follows:

(a) Dilute Types II or IV cleaners according to amount of soil to be removed: minimum dilution required is 2:1 (2 parts water: 1 part cleaner). Normal dilution ratios are 4:1 for heavy soils and 10:1 for light soils. Type III cleaners can be used full strength or diluted as desired.



REAR COVER AND LEADS  
 NOT SHOWN FOR CLARITY

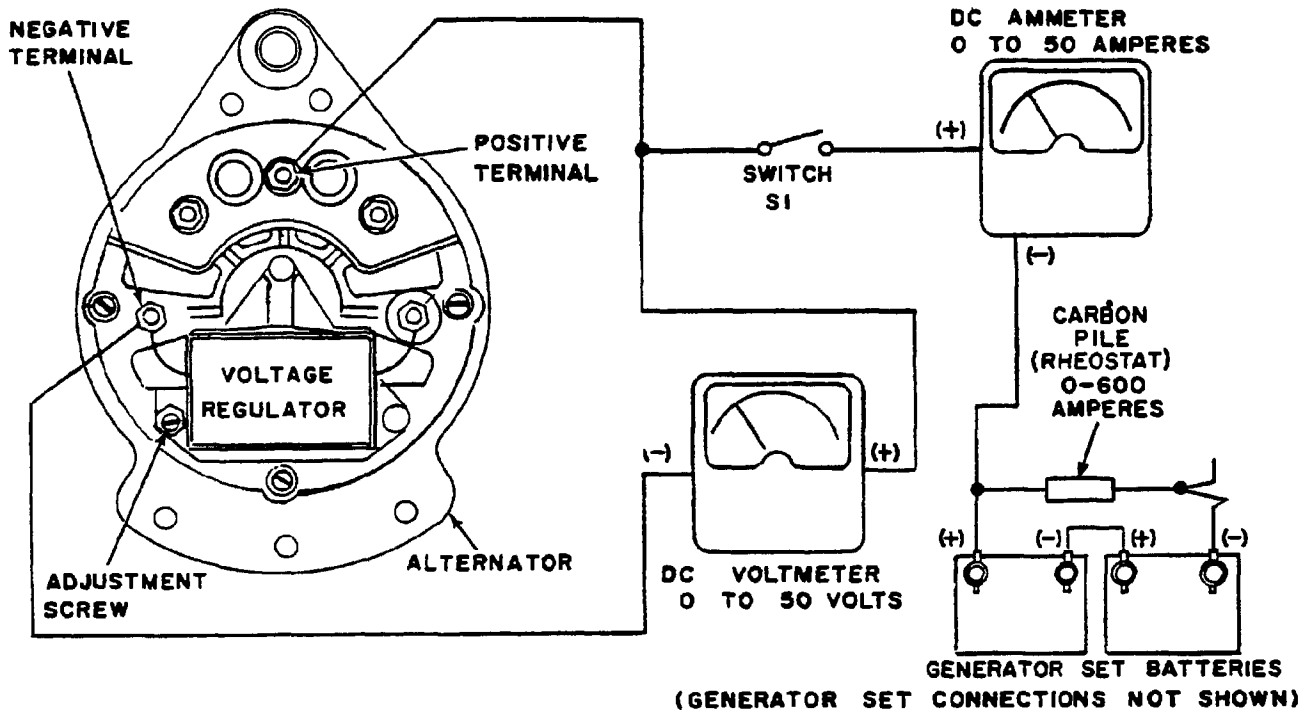

Figure 4-16. Battery Charging Alternator, Test and Adjustment

(b) Heat cleaning solution if desired, following manufacturer's instructions and cautions.

(c) Use a clean, lint-free cloth to apply the cleaning solution and to clean the components.

(d) When components are clean, rinse thoroughly with water.

(e) After cleaning and rinsing components, dry thoroughly.

(3) Inspect for cracks, breaks, and defective threads. Replace defective parts.

d. Installation. Install alternator and mounting group as illustrated in figure 4-17, observing the following:

(1) Tighten plate mounting nuts to  $17 \pm 3$  foot pounds torque ( $23 \pm 4$  Newton-meters).

(2) Install alternator belt and adjust belt, refer to paragraph 4-30.

#### 4-32. WIRING HARNESSSES.

a. General. The following paragraphs describe the various harnesses of the generator set.

(1) Mode I Relay Assembly to Tactical Relay Harness. The harness is connected to connector J51 of the tactical relay assembly A29 and connector J50 of the mode I relay assembly.

(2) Mode I Relay Assembly to Exciter Regulator Harness. The harness is connected to connector J9

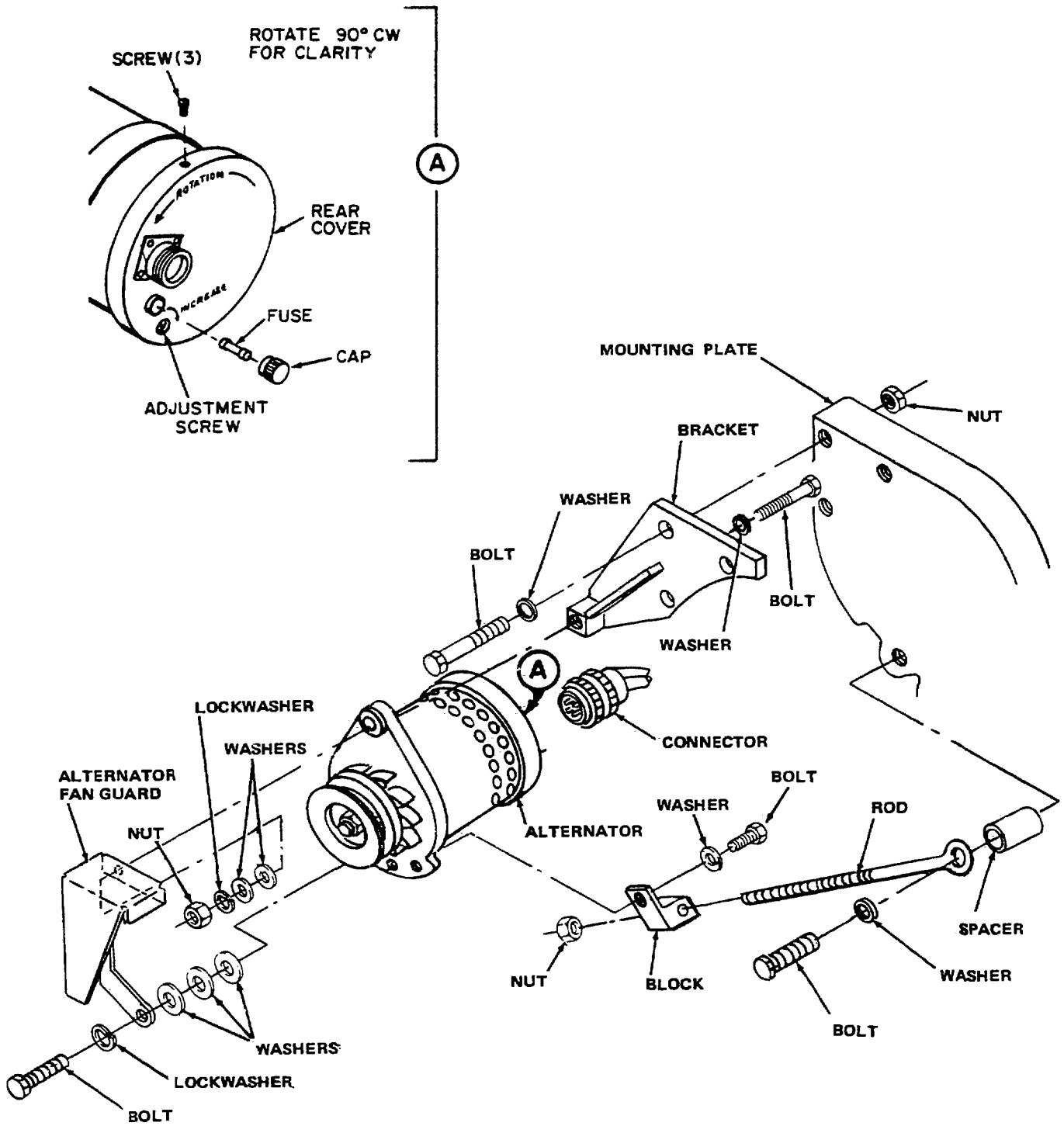

Figure 4-17. Battery Charging Alternator and Mounting Group, Removal and Installation

of the exciter regulator A11 and connector J3 of the mode I relay assembly.

(3) Mode I Relay Assembly to Control Cubicle Harness. The harness is connected to connector J1 of control cubicle A3 and connector J2 of mode I relay assembly.

(4) Mode I Relay Assembly to Reconnection Board Harness. The harness is connected to contactor J10 of mode I relay assembly, connector J13 of the exciter regulator A11, connector J41 of load circuit breaker CB2, connector J48 of convenience receptacle A22, connector J61 of generator G1, and to terminals of the load board and terminal boards, TB2 and TB6.

(5) Engine Harness. The harness is connected to connector J5 of mode I relay assembly, J14 of high coolant temperature switch, J33 of day tank float switch, J35 of air cleaner indicator switch, J36 of day tank solenoid valve, J37 of speed switch, J38 of ether starting aid primer, J39 of DC control circuit breaker, J42 of low oil pressure switch, J43 of alternator, and low oil pressure transmitter, coolant temperature transmitter, fuel level transmitter, fuel transfer pumps, engine shutdown solenoid valve, starter, starter solenoid, and radio suppression diode assembly.

(6) Tactical Relay Assembly to Load Measurement Unit Harness. The harness is connected to connector J4 of tactical relay assembly A29 and connector J16 of load measurement unit A8.

(7) Mode I Relay Assembly to Fault Indicator Harness. The harness is connected to connector J12 of fault indicator A9 and to connector J6 of mode I relay assembly A27.

b. On Generator Set Test.

(1) Tag and disconnect individual harness wires from connection points.

(2) Test each harness wire for continuity, shorts to connector

case, and for shorts to surrounding wires (refer to F0-1 and F0-2).

(3) Repair or replace defective harness. Connect harness connectors and individual wires.

c. Removal. Refer to figure 4-18 and remove wiring harness. Pay particular attention to the following:

WARNING

Disconnect negative battery cable prior to performing maintenance.

(1) Disconnect negative battery cables.

(2) Tag harness connectors and wires prior to removal.

(3) Cut tiedown straps securing harnesses to each other.

(4) Remove clamps and their harnesses.

d. Cleaning.

WARNING

Dry cleaning solvent, P-D-680, Type II, is flammable and moderately toxic to the skin, eyes, and respiratory tract. Skin, eye, and respiratory protection is required.

(1) Clean harnesses with a clean lint-free cloth moistened in cleaning solvent, P-D-680, Type II, and dry thoroughly.

WARNING

Compressed air used for cleaning can create airborne particles that may enter the eyes. Pressure shall not exceed 30 psig (206 kPa). Wearing of goggles is required.

(2) Clean pin of connectors with compressed air.

e. Inspection.

(1) Inspect connectors for damaged threads, bent, loose or missing pins. Check each pin for shorts to core and surrounding pins.

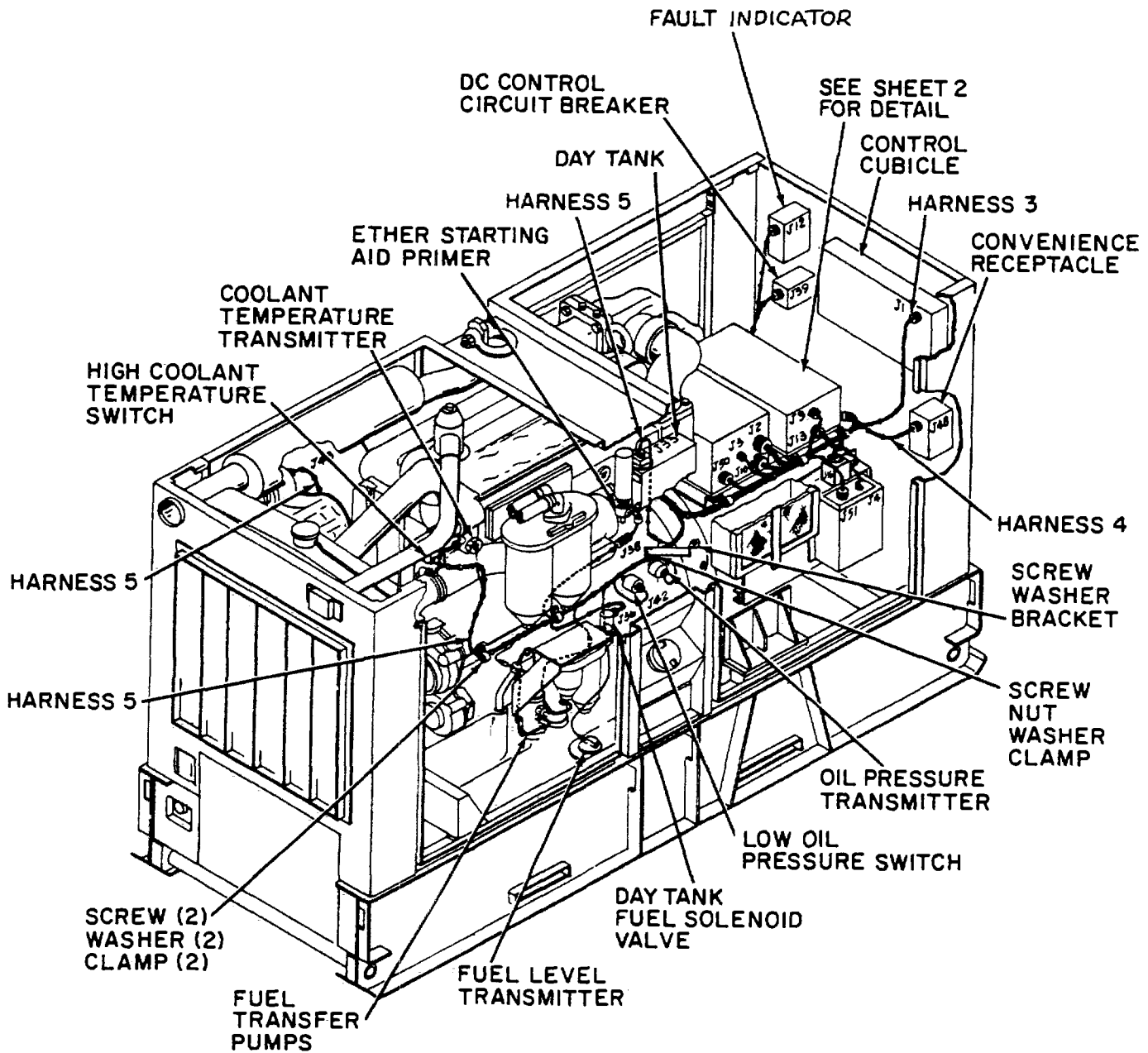
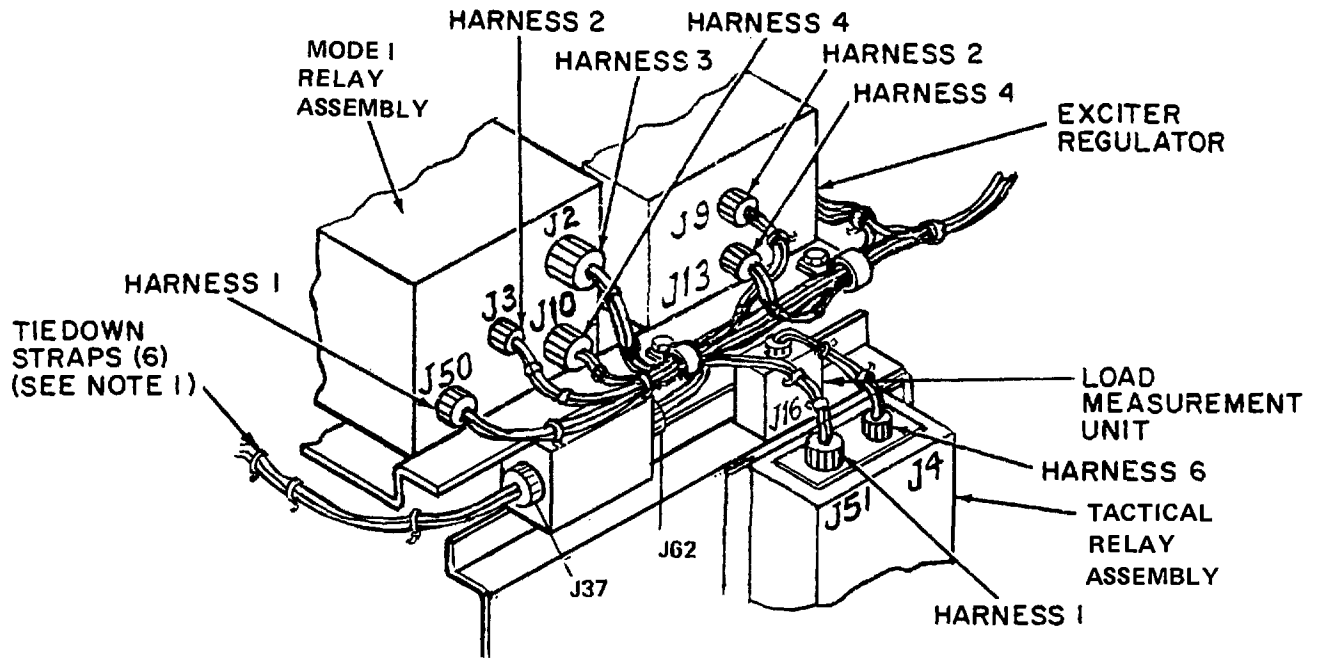

Figure 4-18. Wiring Harnesses, Removal and Installation (Sheet 1 of 5)



**HARNESSES NOMENCLATURE**

1. MODE I RELAY ASSEMBLY TO TACTICAL RELAY ASSEMBLY
2. MODE I RELAY ASSEMBLY TO EXCITER REGULATOR
3. MODE I RELAY ASSEMBLY TO CONTROL CUBICLE
4. MODE I RELAY ASSEMBLY TO RECONNECTION BOARD
5. ENGINE HARNESS
6. TACTICAL RELAY ASSEMBLY TO LOAD MEASUREMENT UNIT
7. MODE I RELAY ASSEMBLY TO FAULT INDICATOR

**NOTES:**

1. HARNESSES JOINING IN COMMON RUN FROM ONE SIDE OF ENGINE TO OPPOSITE SIDE TO BE BOUND TOGETHER AT SIX INCH INTERVALS WITH TIEDOWN STRAPS.
2. GENERATOR LEADS TO PASS THROUGH CURRENT TRANSFORMERS IN DIRECTION SHOWN. LEADS PASSING THROUGH CURRENT TRANSFORMERS CT4, CT5, AND CT6 TO MAKE TWO TURNS AS SHOWN.
3. NEGATIVE LEADS ARE BLACK AND POSITIVE LEADS ARE RED.

Figure 4-18. Wiring Harnesses, Removal and Installation (Sheet 2 of 5)

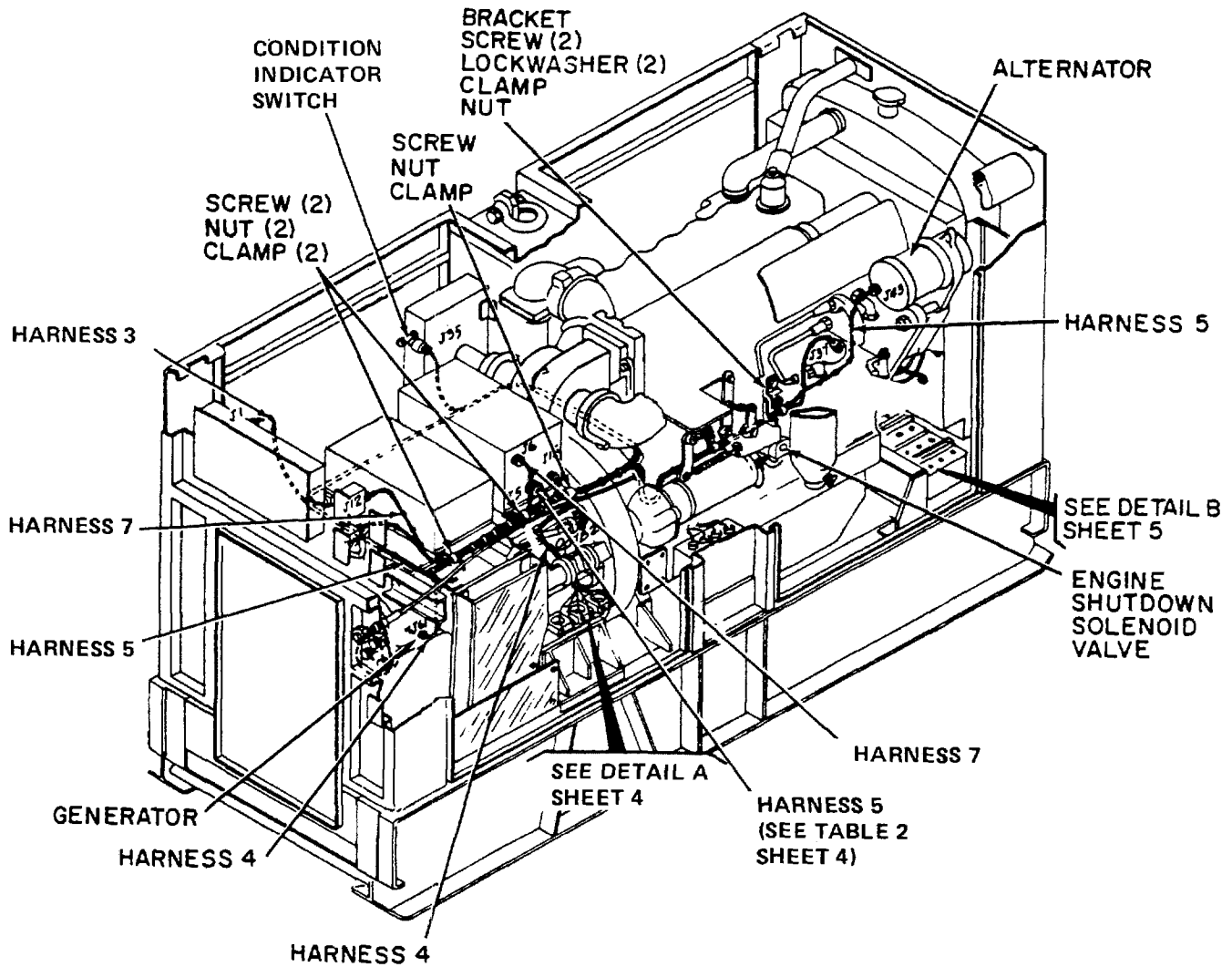

Figure 4-18. Wiring Harnesses, Removal and Installation (Sheet 3 of 5)



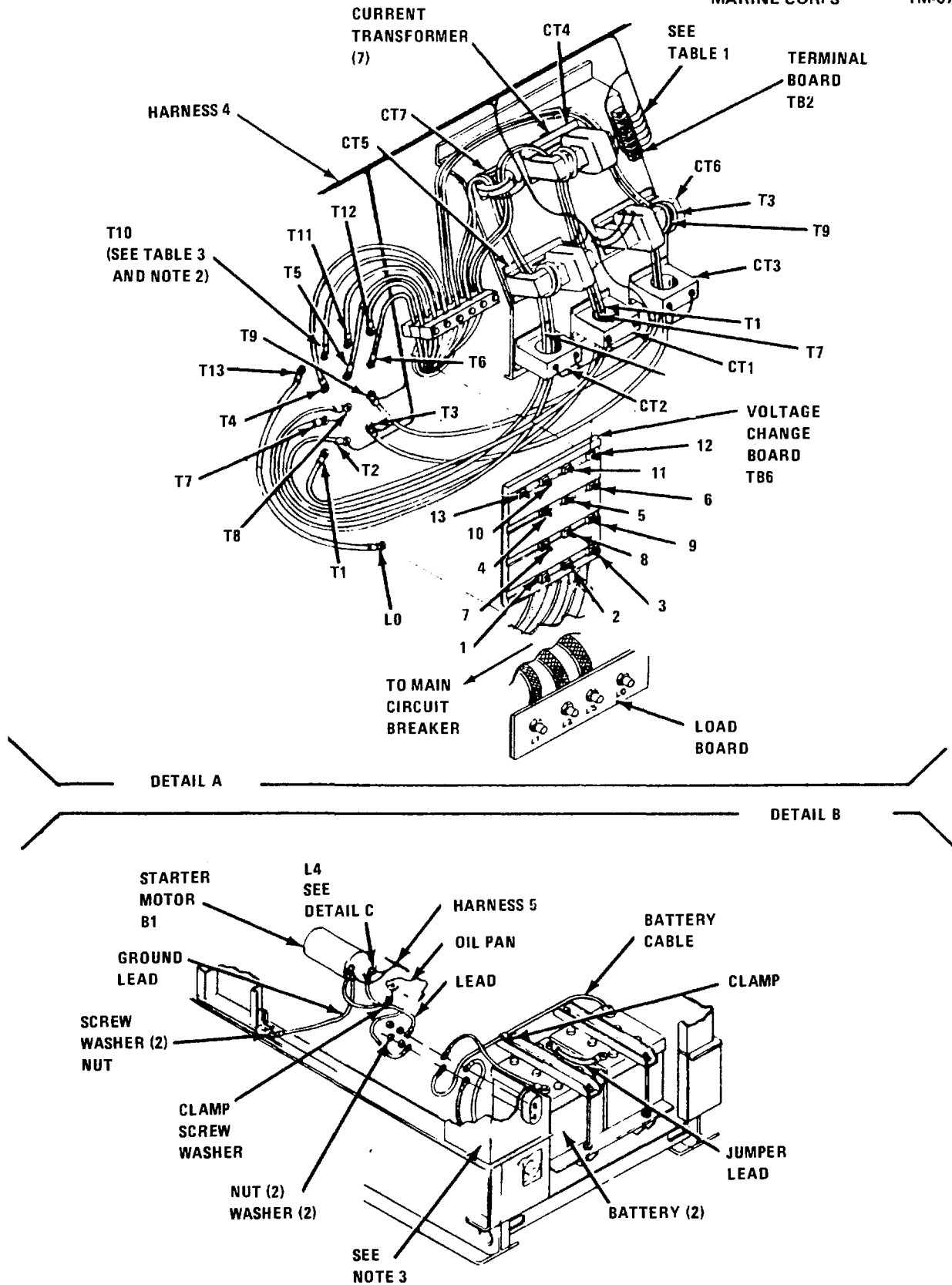

Figure 4-18. Wiring Harnesses, Removal and Installation (Sheet 4 of 5)

TABLE 1

HARNESSTERMINATION		
WIRE NUMBER	TERMINATION	
	FROM	TO
U135A16	TB2-1	CT6-X2
U135E16	TB2-2	CT4-X2
U135F16	TB2-2	CT5-X2
U134A16	TB2-3	CT6-X1
U134E16	TB2-4	CT4-X1
U134F16	TB2-4	CT5-X1
X7E16	TB6-7	
X8E16	TB6-8	
X9AA16	TB6-9	
X19B16	CT3-X1	
X18B16	CT2-X1	
X17B16	CT1-X1	
D22E16	CT3-X2	
D21E16	CT2-X2	
X21S16	CB2-A2	
X22S16	CB2-B2	
X12X16	TB6-12	
X6B16	TB6-6	
X194F16	TB2-5	
X195E16	TB2-6	
X14A16	TB6-1	
X15F16	TB6-2	
X16A16	TB6-3	
U134B16	TB2-4	
U135B16	TB2-2	
X9DD16	TB6-9	
X12SS16	TB6-12	
X12MM12	TB6-12	
X9MM12	TB6-9	

TABLE 2

HARNESSTERMINATION	
WIRE NUMBER	TERMINATION
E39D16	MT1
E38D16	MT2
E37D16	MT3
P55R16	L1-1
P80K16	L1-2
P41B16	L4-1
P55D12	B1
P140D12	L4-3

TABLE 3

GENERATOR LEAD & CABLE TERMINATION		
WIRE NUMBER	TERMINATION	
T1	TB6-1	
T2	TB6-2	
T3	TB6-3	
T4	TB6-4	
T5	TB6-5	
T6	TB6-6	
T7	TB6-7	
T8	TB6-8	
T9	TB6-9	
T10	TB6-10	
T11	TB6-11	
T12	TB6-12	
LO LEAD	FROM	TO
	TB6-13	LO

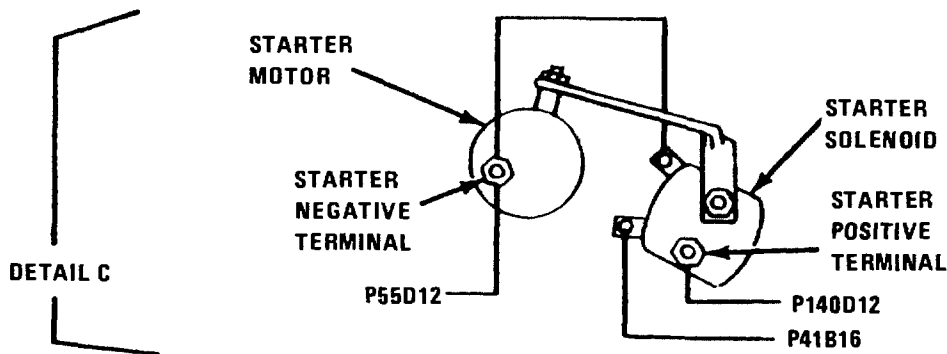

Figure 4-18. Wiring Harnesses, Removal and Installation (Sheet 5 of 5)

- (2) Inspect terminal lugs for security and condition.
- (3) Inspect wiring for defective insulation.
- (4) Test each harness wire for continuity (refer to FO-1 and FO-2).

f. Repair. Repair harnesses by accomplishing the most efficient repair procedure listed below.

WARNING

Disconnect negative battery cable.

NOTE

Repair procedure may be accomplished with harness installed in generator set.

- (1) Disconnect and, if possible, remove defective wire. Connect new wire of same size and type, to terminals from which defective wire was removed. Secure new wire to harness using tiedown straps.
- (2) Remove defective portion of wire and connect wire ends with an insulated solderless wire connector.

CAUTION

Under no condition, leave bare connection exposed.

- (3) Replace defective terminal lugs or connectors.
  - (4) If disconnected, connect negative battery cable.
- g. Installation. Refer to figure 4-18 and install wiring harnesses. Pay particular attention to the following:
- (1) Connect harness connectors and wires.
  - (2) Secure harnesses with clamps.
  - (3) Join harnesses in common run from one side clamp of engine to opposite side clamp at 6 inch (150 mm) intervals with tiedown straps.

- (4) Refer to FO-3 and check harnesses for proper connection.
- (5) Connect negative battery cable.

4-33. SPEED SWITCH AND MAGNETIC PICKUP.

a. General. Overspeed switch S9 (mounted just below the mode I relay box assembly) operates in conjunction with the magnetic pickup (mounted on the right side of the engine flywheel housing) to control speed-related functions of the generator set.

b. Inspection. Visually inspect the speed switch S9 for obvious signs of damage; loose connections; frayed or broken wires.

c. Removal and Installation. To remove or install speed switch S9 and magnetic pickup, proceed as follows:

NOTE

Steps (1) through (4) pertain to removal procedures; steps (5) through (8) pertain to installation.

- (1) Unscrew and disconnect plugs J62 and J37 from speed switch.
- (2) Remove four screws that secure speed switch to mounting bracket and remove speed switch.
- (3) Unscrew and disconnect plug connected to magnetic pickup.
- (4) Using a wrench, remove magnetic pickup from side of flywheel housing.
- (5) Place speed switch S9 in position on mounting bracket and secure in place with four screws.
- (6) Reconnect plugs J62 and J37.
- (7) Using a wrench, screw magnetic pickup a few turns into position at side of flywheel housing. Refer to next higher level of maintenance for magnetic pickup alignment procedures.
- (8) Connect plug to magnetic pickup.

#### 4-34. LOW OIL PRESSURE SWITCH OP.

a. General. The low oil pressure switch OP consists of two independent, double breaker, circuit type switch elements. As engine oil pressure increases, circuit 1 (between pins A and D) contacts close completing circuit for normal operation and circuit 2 (between pins B and C) contacts open turning off the fault locator low oil pressure indicator. If oil pressure drops to  $15 \pm 3$  psig ( $103 \pm 20$  kPa), circuit 1 contacts open initiating shutdown sequence of the generator set and circuit 2 contacts close causing the low oil pressure indicator to light.

#### b. On Generator Set Test.

##### NOTE

A test cable may be locally manufactured using connector plug NSN: 7510-00-282-8201, four alligator clips, NSN 5935-00-813-4714, and four, 36 inch long, #16 gage wires. Label the alligator clips A, B, C and D. The test cable may be used to bring the test points out, making the testing easier to accomplish

(1) Refer to figure 4-19 and remove connector P42 from low oil pressure switch. Install a suitable jumper between connector P42 pins B and C to complete engine run circuit.

(2) Check for continuity between pins A and D of low oil pressure switch connector J42; there should be continuity. Check for continuity between switch pins B and C, there should be an open circuit (no continuity).

(3) Start engine. As oil pressure builds up to approximately 15 psig, switch should actuate. When switch actuates, there should be no continuity between switch pins A and D, and continuity between pins B and C.

(4) Shut down engine. Remove jumper from connector P42. Replace defective switch and reconnect connector P42.

c. Removal. Remove low oil pressure switch OP as illustrated in figure 4-19. Plug engine opening after switch removal.

#### d. Bench Test.

(1) Connect a pressure source, bleed valve, and gage to pressure switch.

(2) Apply 25 psig (172 kPa) to switch. Decrease pressure to  $15 \pm 3$  psig ( $102 \pm 20$  kPa) while checking continuity. There should be continuity between pins A and D until pressure reaches  $15 \pm 3$  psig ( $103 \pm 20$  kPa) and no continuity below  $15 \pm 3$  psig ( $103 \pm 20$  kPa). There should be no continuity between pins B and C until pressure reaches  $15 \pm 3$  psig ( $103 \pm 20$  kPa) and continuity below  $15 \pm 3$  psig.

(3) Remove test equipment from switch. Replace defective switch

e. Installation. Install low oil pressure switch as illustrated in figure 4-19. Apply thread sealing compound conforming to Military Specification MIL-S-45180, Type III, to pipe threads prior to installation.

#### 4-35 HIGH COOLANT TEMPERATURE SWITCH WT.

a. General. The high coolant temperature switch WT consists of two independent, double breaker circuit type switch elements and is located to the left and behind the oil filters. Circuit 1 (between pins A and D) contacts are normally closed and circuit 2 (between pins B and C) contacts are normally open. If engine coolant temperature reaches  $222^{\circ}\text{F}$

(104.5°C) the circuit contacts will switch. Circuit 1 contacts will open and initiate shutdown sequence of the generator set. Circuit 2 contacts will close and cause the fault locator coolant temperature high indicator to light.

b. Inspect. Inspect the high coolant temperature switch WT for obvious signs of damage; loose mounting or connections; frayed or broken wires.

c. On Generator Set Test.

#### NOTE

- Engine coolant temperature must be lower than 222°F (104.5°C) during test.

- A test cable may be locally manufactured using connector plug NSN: 7510-00-282-8201, four alligator clips, NSN 5935-00-813-4714, and four, 36 inch long, #16 gage wires. Label the alligator clips A, B, C and D. The test cable may be used to bring the test points out, making the testing easier to accomplish.

(1) Refer to figure 4-19 and remove connector P14 from high coolant temperature switch.



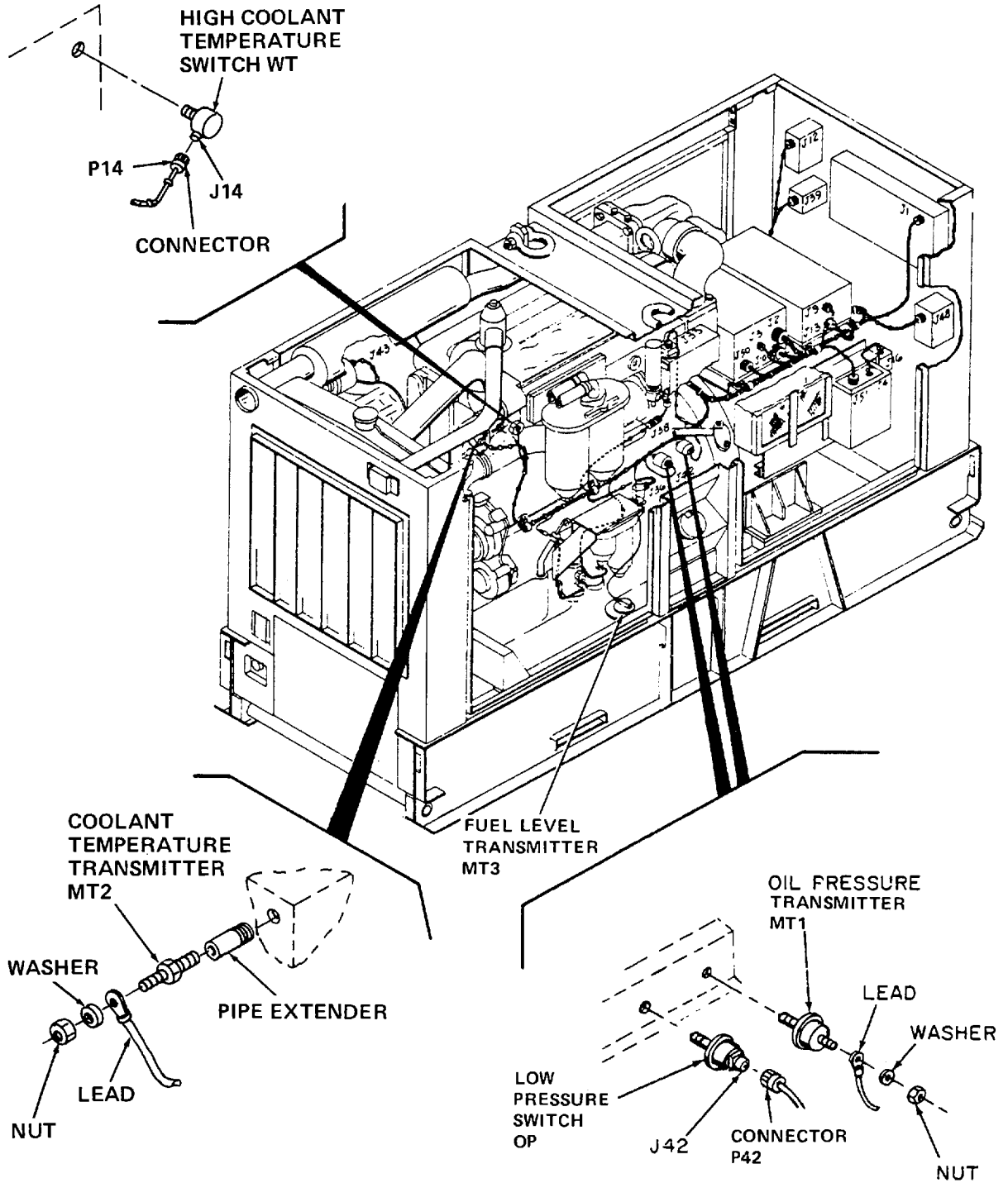

Figure 4-19. Engine Electrical Control Elements, Removal and Installation (Sheet 1 of 2)

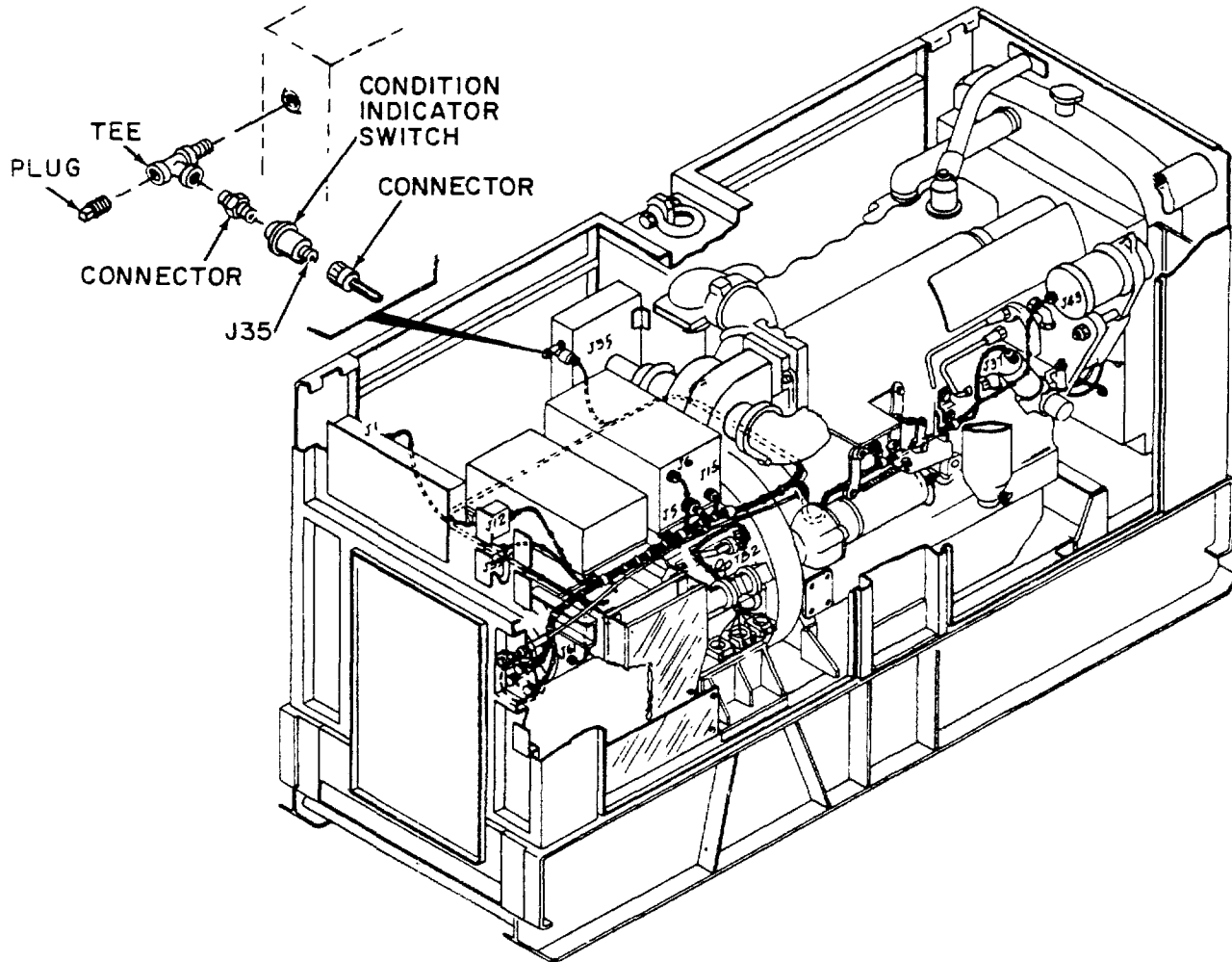

Figure 4-19. Engine Electrical Control Elements  
Removal and Installation (Sheet 2 of 2)

(2) Check for continuity between switch pins A and D; there should be continuity. Check for continuity between pins B and C; there should be no continuity. Replace defective switch.

(3) Connect connector P14 to switch.

d. Removal. Remove high coolant temperature switch as illustrated in figure 4-19, observing the following:

(1) Loosen bolts attaching oil filter support assembly to engine for access and unscrew high coolant temperature switch.

(2) Plug engine opening.

e. Installation. Install high coolant temperature switch as

illustrated in figure 4-19. Apply thread sealing compound conforming to Military Specification MIL-S-45180, Type III, to pipe threads prior to installation.

4-36. RELAYS K3, K5, K7, AND K8. Relays K3, K5, K7, K8, and electronic component assembly in A27, are part of the dc electrical and control system and are mounted within mode I relay box A27. K3, the crank relay, is secured directly to the electronic component assembly, whereas relays K5, K7, and K8 are socket-mounted on dc relay assembly A5, a subassembly of the electronic component assembly. K5, the field flash relay, K7, the parallel operation voltage sensor relay, and K8, the fuel level relay



are identical to one another. To gain access to relays, remove the cover from mode I relay box. The removal, inspection, cleaning, testing, and installation of these relays is described in the following paragraphs.

a. Removal. Remove relay being tested as illustrated in figure 4-20.

b. Inspection. Check relays for broken or bent pins, shorts from pin to case, and signs of obvious damage.

c. Cleaning. Clean relays with a clean lint-free cloth.

d. Testing (Relay K3). To test crank relay K3, proceed as follows:

- (1) Temporarily disconnect connector P5 from mode I relay box.
- (2) Connect a multimeter (set to RX1 scale) across terminals A1 and A2 of relay K3.
- (3) Connect a 24 V dc supply across terminals X1 and X2 of relay K3.

(4) Observe that multimeter reads less than 1 ohm.

(5) Disconnect 24 V dc supply.

(6) Observe that multimeter reads infinite ohms.

(7) Repeat steps (3), (4), and (5), and (6) several times to ensure that relay works consistently.

(8) If multimeter does not produce required reading, relay is defective and must be replaced.

(9) Reconnect connector P5.

e. Testing (Relays K5, K7, and K8). To test relays K5, K7, and K8 (which are identical), proceed as follows:

(1) Remove relay to be tested.

(2) Connect a multimeter (set to RX1 scale) across relay pins 3 and 5.

(3) Connect a 24 V dc supply across relay pins 2 and 7.

(4) Observe that multimeter reads less than 1 ohm.

(5) Disconnect 24 V dc supply.

(6) Observe that multimeter reads infinite ohms.

(7) Connect multimeter across pins 4 and 6.

(8) Reconnect 24 V dc supply to pins 2 and 7.

(9) Observe that multimeter reads less than 1 ohm.

(10) Disconnect 24 V dc supply.

(11) Observe that multimeter reads infinite ohms.

(12) Repeat steps (2) through (11) several times to ensure that relay works consistently.

(13) If multimeter does not produce required reading, relay is defective and must be replaced.

f. Installation. Install relay as illustrated in figure 4-20.

4-37. DC CONTROL CIRCUIT BREAKER CB1. DC control circuit breaker CB1 is located in the control cubicle adjacent to the generator set control panel. It is the main protective device for the direct current components of the generator set. It is rated at 7.5 amperes and performs the function of a master power switch as well as a protective device. Prior to generator set operation, the circuit breaker must be energized, the generator set may be stopped, deenergizing the circuit breaker.

a. Inspect. Inspect the DC control circuit breaker CB1 for obvious signs of damage; loose mounting or connections; frayed or broken wires.

b. Removal. Remove DC control circuit breaker as illustrated in figure 4-21.

c. Test. The DC control circuit breaker may be tested while installed in the generator set or after it has been removed.

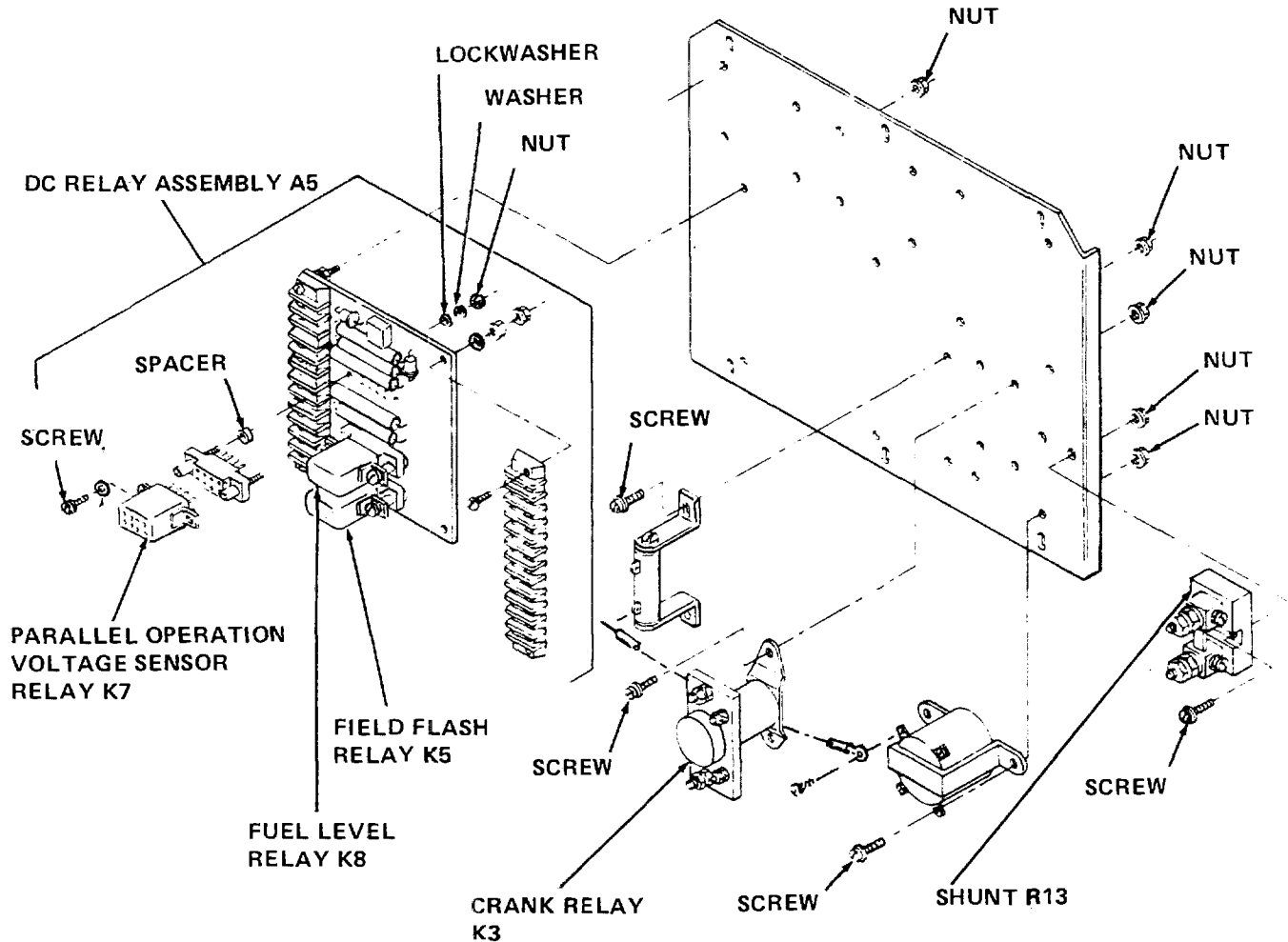

Figure 4-20. Electronic Component Assembly, A27,  
 Relay Removal and Installation

NOTE

Perform steps (1) and (2) on generator set, and step (2) only, if the circuit breaker has been removed.

(1) Disconnect harness from circuit breaker connector from inside generator compartment. Connect harness after test.

(2) Test circuit breaker for continuity at connector J39. There should be continuity between connector pins A, B, and C when circuit breaker is energized and when deenergized between pins B and C only. Replace defective circuit breaker.

d. Installation. Refer to figure 4-21 and install DC control circuit breaker as follows:

(1) Remove four screw and washer assemblies (1) and remove cover (8) as far as wires (5) will allow.

(2) Tag and disconnect wires (5) from DC control circuit breaker (9).

(3) Using appropriate socket wrench, remove locknut and washer that secures DC control circuit breaker to chassis assembly (10) and remove circuit breaker.

4-38. SWITCHES S1, S2, S4, and S7. ENGINE PRIMER switch S1, START-RUN-STOP switch S2, PANEL LIGHT switch S4, and BATTLE SHORT switch S7 are part of dc electrical and control system and are mounted on the control cubicle. Maintenance procedures for these switches are contained in paragraph 4-50.

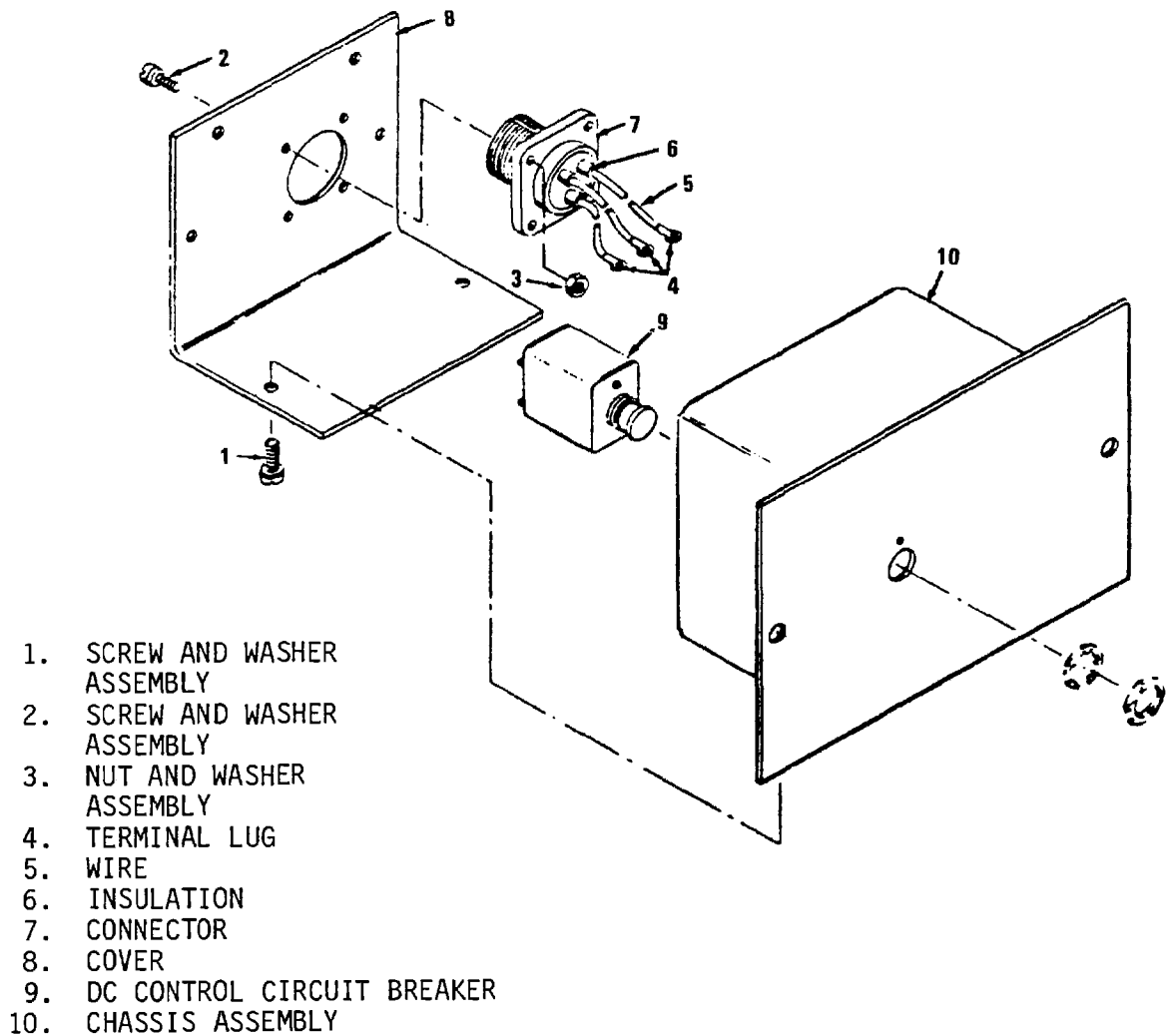

Figure 4-21. DC Control Circuit Breaker, Removal and Installation

4-39. STARTER ASSEMBLY.

a. General. The starter is a 24 V dc, heavy duty, insulated, waterproof, fungus resistant motor with piggy-back mounted solenoid. When electrical power energizes the solenoid, the solenoid plunger shifts the starter pinion to engage the flywheel and permits the starter to turn the engine. When the engine reaches a predetermined speed, the pinion is automatically disengaged from the flywheel.

b. Test. Test starter and solenoid as specified in figure 4-22.

WARNING

Disconnect negative battery cables prior to performing maintenance.

NOTE

Two crew members are required to remove starter because of its weight.

c. Removal. Remove starter and solenoid as illustrated in figure 4-23, observing the following:

(1) Remove starter and solenoid from engine and then solenoid from starter.

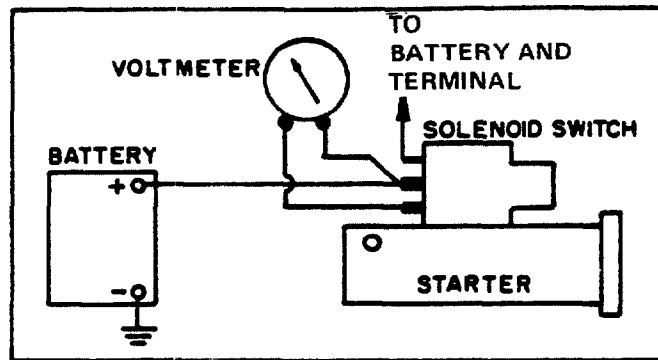

A

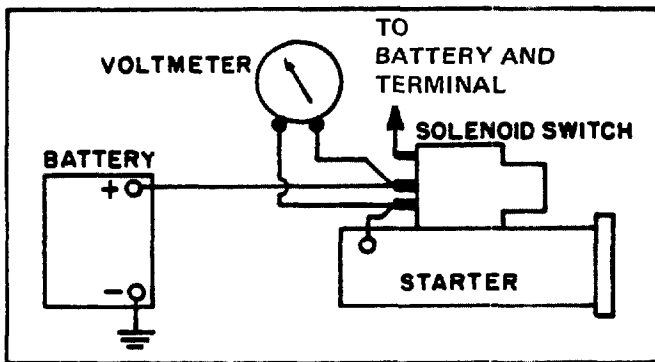

B

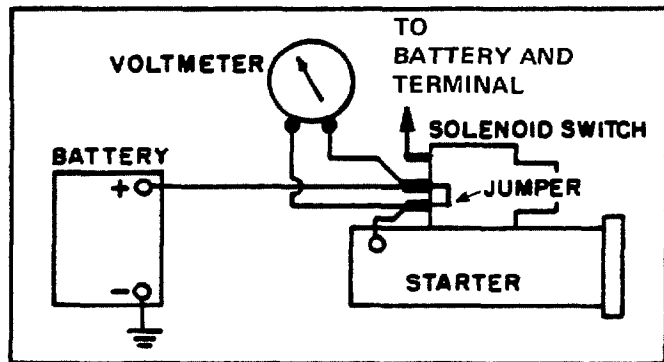

C

Figure 4-22. Starter and Solenoid, Test

STEP 1

DETERMINE THAT BATTERIES ARE FULLY CHARGED AND THAT ALL BATTERY AND STARTER CABLES ARE SERVICEABLE AND PROPERLY INSTALLED.

STEP 2

REMOVE SOLENOID-TO-STARTER CONNECTOR AND CONNECT VOLTMETER AS SHOWN IN A ABOVE. IF VOLTAGE IS INDICATED, SOLENOID SWITCH IS DEFECTIVE AND MUST BE REPLACED.

STEP 3

INSTALL SOLENOID-TO-STARTER CONNECTOR.

STEP 4

CONNECT VOLTMETER AS SHOWN IN B ABOVE. IF BATTERY VOLTAGE (24 VOLTS) IS NOT INDICATED, THE STARTER IS DEFECTIVE AND MUST BE REPLACED.

STEP 5

MOMENTARILY CONNECT A JUMPER AS SHOWN IN C ABOVE. THE VOLTMETER READING SHOULD DROP TO ZERO AND STARTER SHOULD CRANK ENGINE. IF ENGINE DOES NOT CRANK, REPLACE SOLENOID. IF VOLTMETER READING DROPS TO ZERO BUT STARTER FAILS TO CRANK ENGINE, STARTER IS DEFECTIVE AND MUST BE REPLACED.

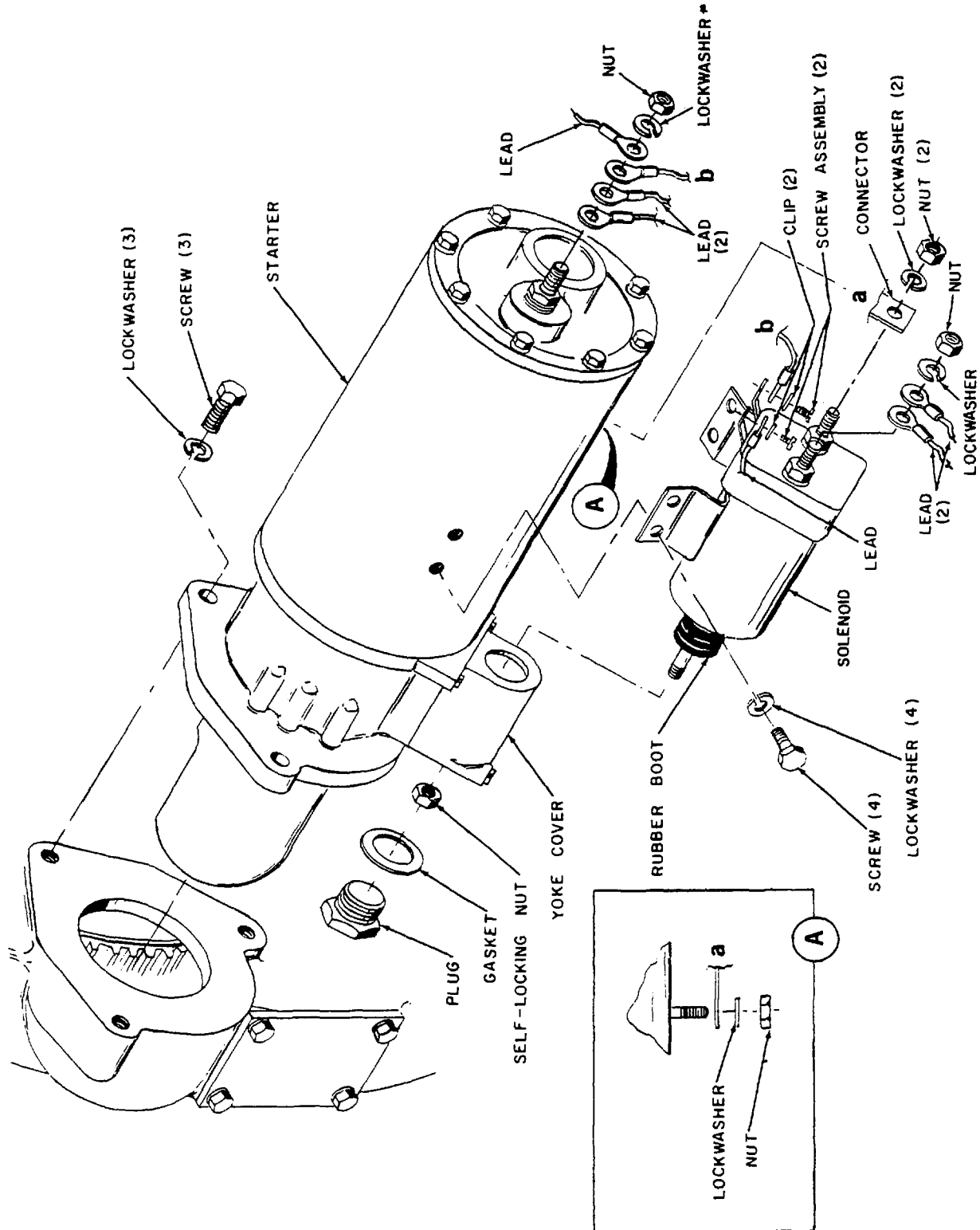

Figure 4-23. Starter and Solenoid, Removal and Installation

(2) To disconnect self-locking nut from solenoid shaft, place a deep 1/2 inch socket on nut and place a 5/32 inch Allen wrench through socket drive into shaft. Hold shaft stationary with Allen wrench and remove nut by turning socket. Count number of turns to remove nut from shaft.

d. Installation. Install starter and solenoid as illustrated in figure 4-23, observing the following:

(1) Install solenoid on starter making sure rubber boot is on inside of yoke cover and over outside edge of solenoid case for proper seal.

(2) To connect self-locking nut to solenoid shaft, hold shaft with 5/32 inch Allen wrench and tighten nut same number of turns on shaft required for removal. Do not install plug and gasket at this time.

(3) Adjust drive assembly pinion clearance by performing steps

(4) through (7).

(4) Connect a 12 volt battery to starter and solenoid as shown in A of figure 4-24.

CAUTION

Do not keep jumper connected for more than 15 seconds at a time. Wait approximately 3 minutes before reconnecting jumper lead.

(5) Momentarily touch jumper between terminal stud of solenoid and terminal stud in commutator end head as shown in A of figure 4-24. This will shift solenoid and drive assembly into cranking position.

(6) Push drive assembly toward commutator end of starter to eliminate any slack in linkage.

(7) Measure distance between outside edge of drive sleeve and thrust washer as shown in B of figure 4-24. This distance should be

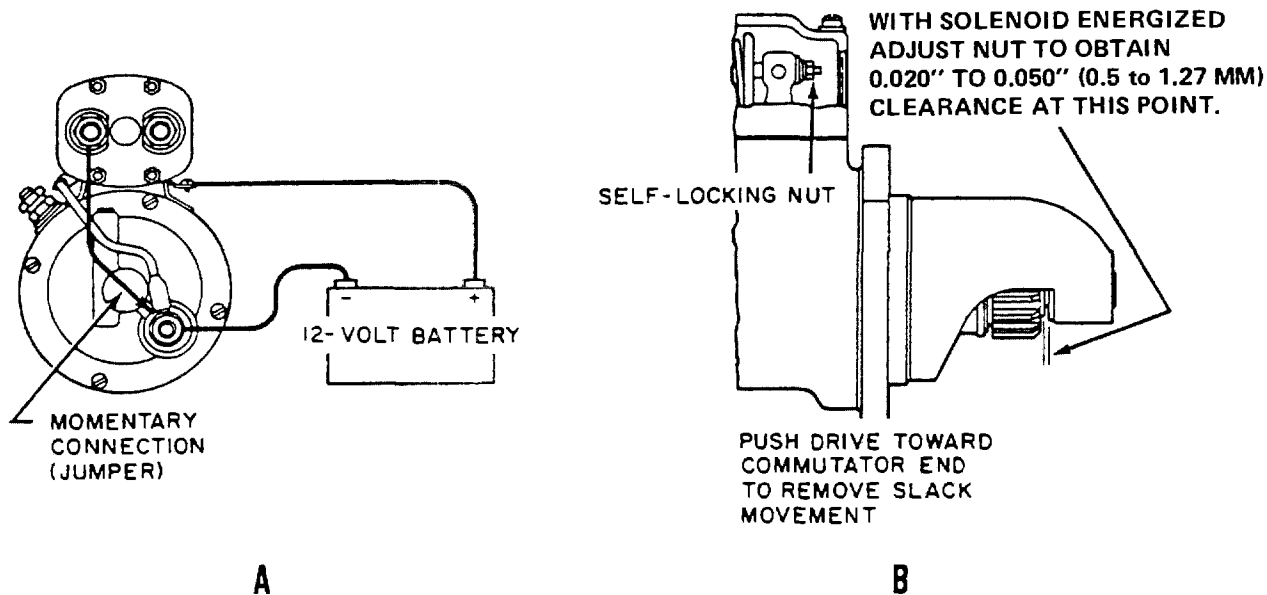

Figure 4-24. Starter Drive Assembly, Pinion Clearance Adjustment

0.020 to 0.050 of an inch (0.5 to 1.27 mm). If measurement is not correct, adjust self-locking nut as required to obtain proper distance. Remove test equipment.

(8) Install plug and gasket in yoke cover, figure 4-23.

(9) Install starter and solenoid on engine.

#### 4-40. FUEL SHUTDOWN SOLENOID L1.

a. General. Fuel shutdown solenoid L1, which is mounted at the rear of the fuel injection pump (see figures 4-25 and 4-63), when energized, allows fuel to reach the fuel injection pump thus enabling engine operation. Deenergizing L1 cuts off this fuel which shuts down the engine.

b. Inspect. Inspect fuel shutdown solenoid L1 for signs of overheating (discoloration of paint) broken terminals, and loose mounting bolts.

c. Removal. To remove fuel shutdown solenoid L1, refer to figures 4-25 and 4-63, and proceed as follows:

(1) Tag and disconnect two wires leading to terminals at rear of solenoid.

(2) Loosen and remove two bolts that secure L1 to side of drive group adapter.

(3) Gently rock L1 until it is free of adapter.

(4) Retain gasket if reusable.

d. Test. To test fuel shutdown solenoid L1, proceed as follows:

(1) Connect fuel shutdown solenoid L1 in series with a 24-volt battery, a single-pole, single-throw switch (see to off) and a dc ammeter (0 to 15 amperes).

(2) Set switch to on position and note reading on dc ammeter: current should rise to 10 amperes (pull-in current) at first and then drop to 2 amperes (hold-in current). Plunger shaft and spring

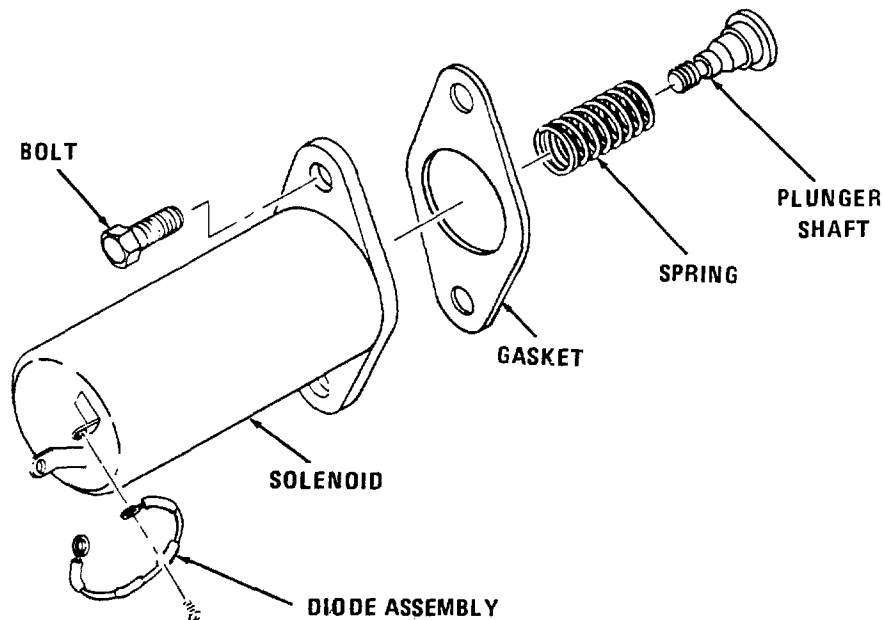

Figure 4-25. Fuel Shutdown Solenoid L1, Exploded View

should compress a distance of approximately 0.9 inches (22 mm).

(3) Repeat step (2) several times to ensure free movement of plunger shaft and spring.

(4) Disconnect test equipment.

#### NOTE

If the solenoid is found to be defective, the plunger shaft

(which screws into the solenoid) and spring may be reused.

e. Replacement. To replace fuel shutdown solenoid L1, proceed as follows:

(1) Insert replacement solenoid and gasket into adapter opening.

(2) Secure in place with original two bolts.

(3) Reconnect wires to solenoid as indicated by tagging.

## Section X. MAINTENANCE OF SET CONTROLS AND INSTRUMENTATION

4-41. GENERAL. The set controls and instrumentation provide the operator with a visual readout of the various operating parameters as well as permitting the running, stopping, and control of the generator set during its various operating modes.

4-42. FAULT INDICATOR ASSEMBLY A9. FAULT INDICATOR assembly A9 is a self-contained unit with solid-state circuitry. On its front panel are ten red malfunction indicators, each for a specific fault (the UNDER FREQ and UNDER VOLT indicators are not functional), a 1-ampere fuse to protect against overload, and a double-pole, double-throw (DPDT) spring-loaded switch. The function of the indicator assembly is to make known the presence of a particular malfunction when one of the protective devices is activated. Refer to paragraph 4-28e for theory of operation discussion of the FAULT INDICATOR assembly.

#### a. Inspection.

(1) Refer to paragraph 4-42d and remove the FAULT INDICATOR assembly (see figure 4-26).

(2) Remove five screws (1) and cover (2).

(3) Inspect harness wiring for continuity and defective insulation.

(4) Inspect harness connector for damaged threads; bent, loose, or missing pins; and for shorts.

(5) Check electrical components for open circuits, short circuits, continuity and proper values (refer to figure 4-26 and 4-27).

(6) Check diodes for forward and reverse resistance. Measured from anode (+) to cathode (-), resistance should be low. Reverse leads, value should be at least 100 times greater than forward resistance.

(7) Inspect printed circuit board (24) for damage, burns, discolored areas, and signs of overheating. Inspect components for security, and circuits for breaks and damage.

(8) Inspect base of printed circuit board for cracks warping, burned or discolored areas, and illegible stenciling.

(9) Inspect sheet metal parts for bent corners, distortion, cracks, tears, and dents.

(10) Check terminal lugs for security and condition.

(11) Inspect relay sockets for damage and shorts between case and surrounding pins.

(12) Inspect for broken indicator lenses.

(13) Check fuse for continuity.



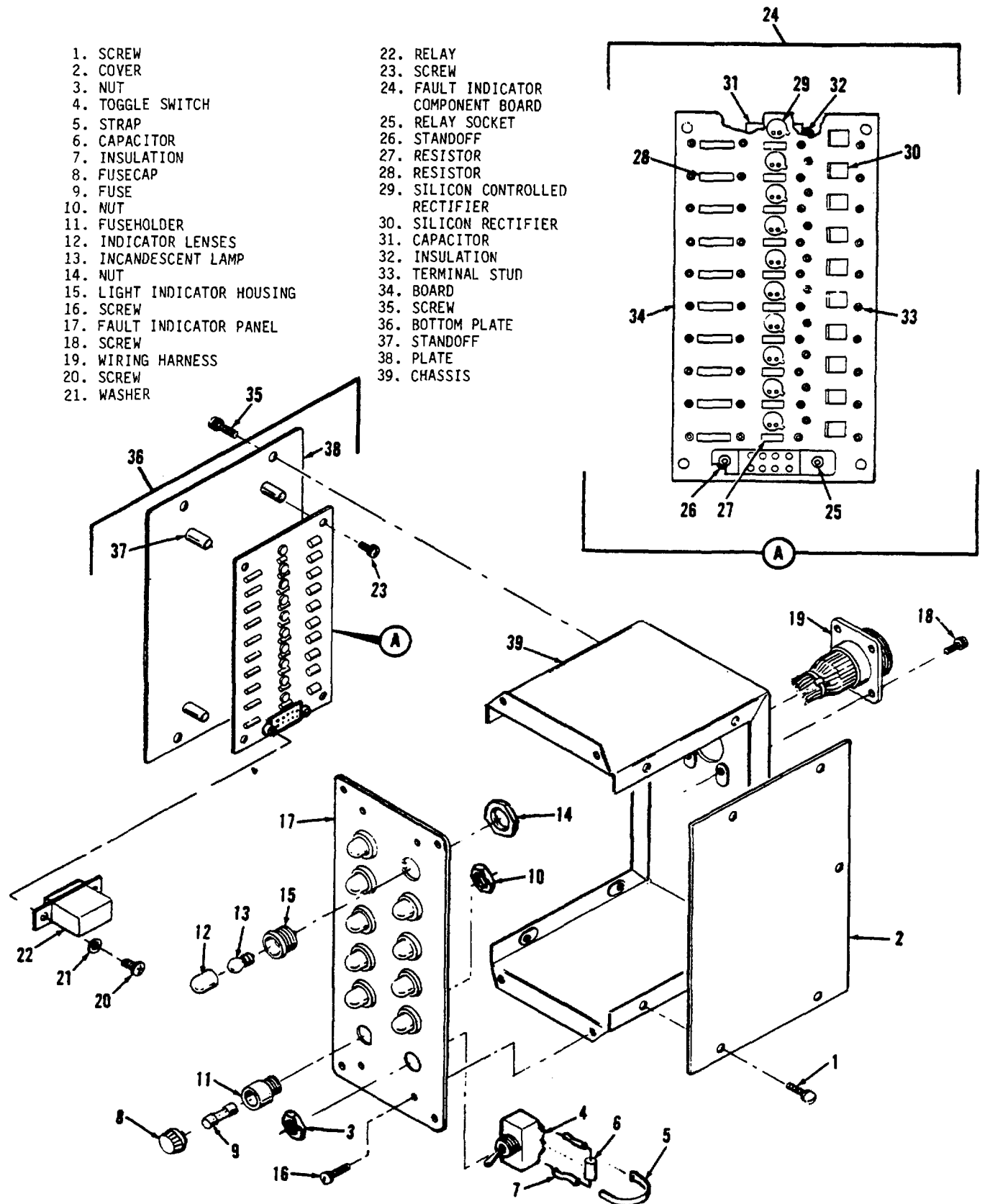

Figure 4-26. FAULT INDICATOR Assembly A9, Exploded View

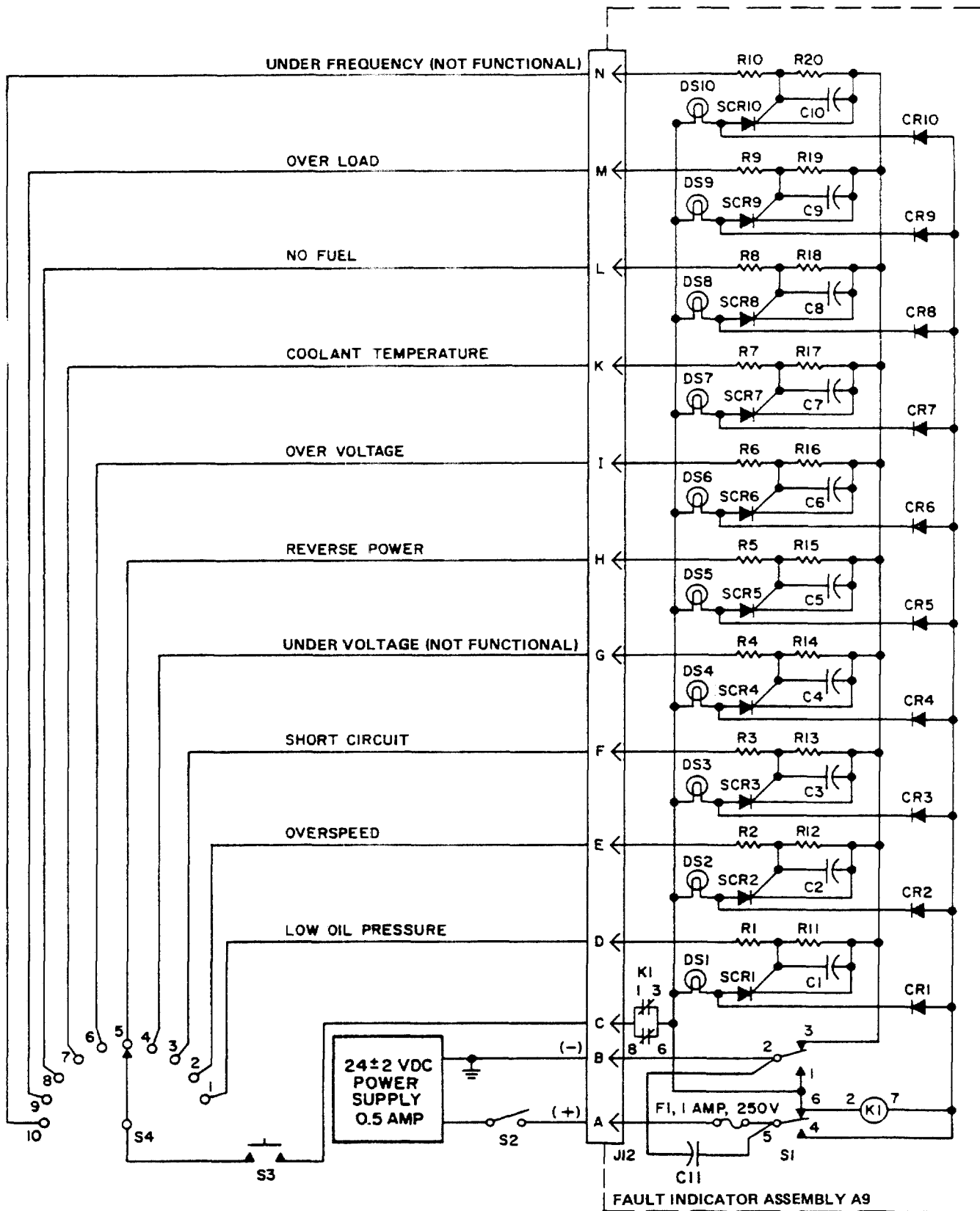

Figure 4-27. FAULT INDICATOR Assembly A9, Test Setup

(14) Replace cover (2) using five screws (1).

(15) Install FAULT INDICATOR assembly A9 (refer to paragraph 4-42d).

b. On-Equipment Test. A malfunction of FAULT INDICATOR assembly A9 is usually the absence of a fault indication during a fault condition. Another malfunction is a false indication which cannot be reset. To isolate the malfunctions proceed as follows:

NOTE

Refer to figures 4-26 and 4-27 for circuitry, component layout, and wiring.

(1) No Indication.

(a) Set switch S1 to TEST OR RESET: all the indicators DS1 through DS10 should light.

(b) Check for defective indicator lamp if one or two do not light.

(c) If none of the lamps light, check fuse F1.

(d) If fuse F1 is not defective, remove plug P12 and check pins A (+) and B (-) for 24 V dc.

(e) With the above requirements met and indicators not lit, check wiring to fault sensor. For example, high coolant pins C-K in connector P12 with fault simulated should have continuity. Reconnect P12 and simulate a high coolant fault; if indicator lamps DS7 does not light, refer repair of assembly to next higher level of maintenance or replace the FAULT INDICATOR assembly. Similar test procedures will apply to remaining faults.

(2) False Fault Indication Cannot Be Reset.

(a) Remove P12 and check for continuity from pin C to applicable pin of P12 for the circuit showing false indication. Open circuit should be indicated.

(b) If circuit is open, repair (refer to next higher level of maintenance), or replace the fault indicator box.

c. Bench Test. To bench test A9, proceed as follows:

(1) Remove the FAULT INDICATOR assembly A9 (refer to paragraph 4-42d).

(2) Connect A9 to test equipment as illustrated in figure 4-27 and perform test specified in procedural analysis table 4-4.

d. Replacement.

(1) Disconnect plug P12 from the receptacle connector J12 in the rear wall of the box, then remove the four screws which secure the FAULT INDICATOR assembly to the rear housing.

(2) Install FAULT INDICATOR assembly in the rear housing and secure in position using four screws. Connect plug P12 to the receptacle connector J12 located in the rear wall of the FAULT INDICATOR assembly.

4-43. CONTROL BOX ASSEMBLY A3.

a. General. Control box assembly A3 (control cubicle) is located at the generator end (rear) of the set and contains controls, switches, instruments, and circuitry necessary to start, operate, and monitor the generator set (see figure 2-2). The instruments and controls are mounted on a hinged front panel which permits easy access to the interior of the cubicle by means of three quick release locking devices which secure the front panel. Devices on the front panel are divided into an engine group and a generator group. Instruments that monitor the generator output are: HERTZ (frequency) meter M6, KILOWATTS meter M7, PERCENT RATED CURRENT meter M8, VOLTS AC meter M9, AMPS-VOLTS selector switch S8, and the SYNCHRONIZING LIGHTS, DS4 and DS5. Devices that control the generator output are: a VOLTAGE ADJUST CONTROL R2, PARALLEL UNIT-SINGLE UNIT

Table 4-4. Fault Indicator Assembly A9, Procedural Analysis

STEP	TEST CONDITION	REQUIRED RESULT	PROBABLE CAUSE FOR IMPROPER RESULT	CHECK OUT PROCEDURE
1.	With test switch S2 open, energize the 24 vdc power supply. Close test switch S2.	None of the fault locator indicators should energize	Shorted or defective switch S1 on fault locator box (if all circuits energize).  Shorted silicon controlled rectifier SCR1 through SCR10 (if only one circuit energizes).	Check continuity with ohmmeter between terminals 2 and 1, and 4 and 5 of switch S1. There should be no continuity.  Measure voltage across anode-cathode of SCR in particular indicator circuit which was energized. If voltage is less than 24 volts, the SCR is defective.
2.	Rotate test switch S4 to position 1 and momentarily depress switch S3. Repeat this procedure for each position of test switch S4.	The particular indicator (DS1 through DS10) for particular position of S4 should energize after momentarily depressing S3.	Defective switch S1 (if all circuits fail to operate properly).  Relay K1 contacts open or defective (if all circuits fail to operate properly).  Defective components in gate bias circuit of particular SCR circuit (if only one circuit fails to operate).  Defective silicon controlled rectifier SCR1 through SCR10 (if only one circuit fails to operate properly).	Check continuity of switch.  Check relay K1 in accordance with paragraph 4-75.  Check applicable resistors R1 through R20, and capacitors C1 through C10.  Measure voltage across anode and cathode of particular SCR for indicator circuit that had improper test results with S3 depressed and held. If voltage is 24 vdc, and gate to cathode voltage is present (approx 1 vdc), SCR is defective.
3.	Set switch S1 to TEST or RESET and hold in this position.	All of the indicator lights DS1 through DS10 should be energized when S1 is held to TEST OR RESET.	Defective switch S1 (if all circuits fail to operate properly).  Defective diodes CR1 through CR10 (if only one circuit fails to operate).	Check continuity of switch S1.  Check diodes by measuring voltage across diode while S1 is in TEST OR RESET position. The voltage should be 0.6 volts.

OPERATION switch S6, BATTLE SHORT switch S7 and indicator DS7, VOLTAGE SENSING (REMOTE-LOCAL) switch S5, and main CKT BRK switch S3 and indicator DS6.

Instruments that monitor engine operation are: OIL PRESSURE meter M1, COOLANT TEMPERATURE indicator M2, FUEL LEVEL meter M3, BATTERY CHG AMMETER M4, and total RUNNING TIME meter M5. Devices that control the engine are a START-STOP-RUN switch S2 and ENGINE PRIMER switch S1. Also included is an AIR CLEANER CONDITION indicator DS8.

Also located in the control cubicle (behind the front panel) are the thermal watt converter A1, control panel relay assembly A4, frequency meter transducer A2, the control box relay assembly, and a wiring harness. The thermal watt converter senses the generator power output and converts it to a proportional dc signal for display by the kilowatt meter. The frequency meter and transducer are a matched set. A single-phase ac voltage of the generator output is applied to the transducer which produces a dc signal proportional to the generator frequency for display by the HERTZ (frequency) meter. The control box relay assembly contains stop-run relay K1, remote voltage sensing relay K6, rectifier bridge CR1, and resistor R10.

b. Inspect.

(1) Release three locking devices and open the control box door.

(2) Inspect meters and gages for damaged cases and faces.

(3) Inspect terminal boards for cracked insulation, stripped threads, and missing jumper strips.

(4) Inspect terminal lugs for security and condition.

(5) Inspect sheet metal parts for bent corners, distortion, cracks, tears, and dents.

c. Test. The control box assembly is not tested as a complete unit. Individual components of the

control box should be tested in accordance with paragraphs 4-44 through 4-67, below.

d. Replace. If, because of excessive damage, it is impractical to repair, the control box assembly is to be replaced as follows:

(1) Open left generator compartment access door and remove electrical connector J1 from rear of control box assembly.

(2) Open upper rear doors and remove screws and washers securing control box. Remove control box assembly from generator set.

(3) Install new control box assembly using screws and washers removed in steps (2) above.

(4) Connect electrical connector J1, to rear of control box assembly.

(5) Close access doors.

e. Repair. For the most part, repair of the control box assembly consists of replacing its individual components. Refer to paragraphs 4-44 through 4-67, below, for replacement procedures.

4-44. VOLTS AC METER M9.

a. General. If the VOLTS AC meter M9, which is located on the control box assembly front panel, indicates line-to-line and line-to-neutral generator output voltage as selected by the AMPS-VOLTS switch. The meter is scaled from 0 to 500 volts with scale divisions of five volts.

NOTE

The generator set should not be running when the following adjustment is made.

b. Adjust. Using a screwdriver, zero-adjust meter M9. The adjustment may be made by turning the screw on the front of the meter in either direction.

WARNING

Do not touch exposed electrical connections with generator set running.

c. On-Equipment Test. To test VOLTS AC meter M9, open the control box assembly front panel and, using a multimeter set to ac volts, measure the voltage at the terminals of M9. Meter M9 should be within +/-5 percent of the multimeter reading. If not, it should be replaced (refer to step d, below).

d. Replacement. Tag and disconnect leads going to meter M9. Remove and replace meter M9 as illustrated in figure 4-28.

4-45. KILOWATTS METER M7.

a. General. The KILOWATTS meter M7, which is located on the control box assembly front panel, works in conjunction with thermal watt converter A1 to monitor generator output power. M7 is a direct current meter (1.2 milliamperes full scale) scaled from 0 to 133 percent of total wattage.

NOTE

The generator set should not be running when the following adjustment is made.

b. Adjust. Using a screwdriver, zero-adjust meter M7. The adjustment may be made by turning the screw on the front of the meter in either direction.

c. Replacement. Tag and Disconnect leads going to meter M7. Remove and replace meter M7 as illustrated in figure 4-28.

4-46. THERMAL WATT CONVERTER A1.

a. General. The thermal watt converter A1 senses generator output power and converts it to a dc signal which is proportional to output power.

The dc signal is then applied to KILOWATTS meter M7, which is scaled in percent of total rated power.

b. Inspect. To inspect thermal watt converter A1 proceed as follows:

(1) Open the control box assembly front panel.

(2) Inspect thermal watt converter A1 (mounted at rear of control box assembly) for broken terminals, cracked terminal strip, loose wires, signs of overheating, such as discoloration, and other signs of damage.

(3) Close control panel and secure in place.

4-47. PERCENT RATED CURRENT METER M8.

a. General. PERCENT RATED CURRENT meter M8 monitors the generator set output current.

NOTE

The generator set should not be running when the following adjustment is made.

b. Adjust. Using a screwdriver, zero-adjust meter M8. The adjustment may be made by turning the screw on the front of the meter in either direction.

c. Replacement. Tag and disconnect leads going to meter M8. Remove and replace meter M8 as illustrated in figure 4-28.

4-48. VOLTAGE ADJUST RHEOSTAT R2.

a. General. The VOLTAGE ADJUST rheostat R2 controls generator set output voltage by varying the voltage sensed at exciter-regulator A11. It is rated at 0 to 25 +/-10 ohms.

b. Inspect. Inspect voltage adjust rheostat R2 for damage. Inspect solder connections for security.

c. Test. To test R2, proceed as follows:

(1) Disconnect electrical connector J1 from control cubicle

harness connector at back of control cubicle. Loosen three captive screws and open control panel.

(2) Connect ohmmeter to rheostat and check ohmic value while rotating rheostat knob. Rheostat ohmic value should vary smoothly the full range 0 to 25 +/-10 ohms. Replace defective rheostat.

(3) Close control panel and secure in place. Connect electrical connector J1 to control cubicle.

d. Replacment. Unsolder and tag leads going to R2. Remove and replace R2 as illustrated by figure 4-29.

4-49. HERTZ (FREQUENCY) METER M6 AND FREQUENCY TRANSDUCER A2.

a. General. HERTZ (frequency)

meter M6 works in conjunction with frequency transducer A2 to sense and indicate generator set output frequency in Hertz (cycles per second). M6 reads from 48 to 53 Hertz for 50 Hertz operation an from 57 to 62 Hertz for 60 Hertz operation. Scale divisions are 1/10 Hertz.

b. Inspect. To inspect M6 and A2, proceed as follows:

(1) Open the control box assembly front panel.

(2) Inspect M6 for broken glass, bent or broken needle pointer, and for other signs of obvious damage.

(3) Inspect A2 (located at rear of control box assembly) for broken terminals, cracked bakelite terminal strip, loose wires, signs of overheating, and other signs of damage.

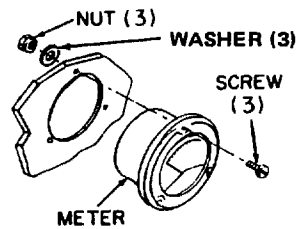

Figure 4-28. Typical Meter, Removal and Replacement

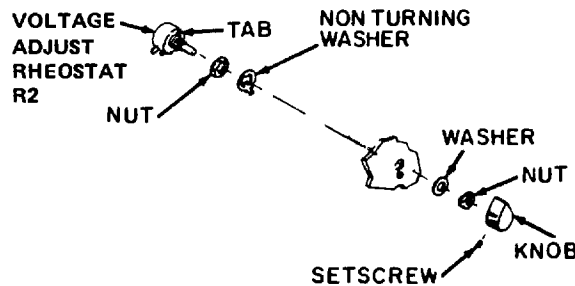

Figure 4-29. VOLTAGE ADJUST Rheostat R2, Removal and Replacement

(4) Close control panel and secure in place.

c. Replacement. Tag and disconnect leads going to M6 and A2. Remove and replace M6 and A2 as illustrated in figure 4-30.

NOTE

M6 and A2 are a matched set and shall be replaced as a set.

4-50. TOGGLE SWITCHES.

a. General. Toggle switches are utilized to control generator set circuits.

(1) BATTLE SHORT switch S7. S7 is a sealed, toggle switch that permits bypassing of all generator set faults except engine overspeed and short circuit for emergency operation only.

(2) PARALLEL OPERATION - SINGLE UNIT OPERATION switch S6. The switch is a sealed toggle that permits selection of parallel or single unit operation. In parallel operation, it activates parallel circuits and SYNCHRONIZING LIGHTS.

(3) VOLTAGE SENSING switch S5. The switch is a sealed toggle that permits selection of voltage regulator sensing and level adjusting circuits either at the set or a remote location.

(4) PANEL LIGHT switch S4. The switch is a sealed toggle that permits turning panel lights on and off.

(5) CKT BRK switch S3. The switch is a sealed toggle that permits opening and closing of circuit breaker CB2.

(6) START-STOP-RUN switch S2. The switch is a spring-loaded, sealed toggle with three positions. The momentary position is utilized for starting, the other positions control generator set operation (run or stop).

(7) ENGINE PRIMER switch S1. The switch is a spring-loaded, sealed toggle switch that permits actuation of the ether starting aid.

b. Test. To test the various toggle switches, proceed as follows:

(1) Disconnect electrical connector from control cubicle harness connector at back of control cubicle.

(2) Loosen three captive screws and open control panel.

(3) Tag and disconnect electrical wiring from switch. Test switch for continuity, refer to F0-2.

(4) Replace defective switch. Connect wiring and close control panel. Secure panel with captive screws.

c. Replacement. Tag and disconnect leads going to toggle switches. Remove and replace toggle switches as illustrated in figure 4-31.

4-51. AMPS-VOLTS SELECTOR SWITCH S8.

a. General. AMPS-VOLTS selector switch S8 is mounted on the generator portion of the generator set control panel. It is a four-deck, rotary switch which permits selection of current in each generator phase, three line-to-line generator voltages, or three line-to-neutral generator voltages for measurement by the VOLTS AC and PERCENT RATED CURRENT meters. All switch contacts are not connected to the generator set system.

b. Test. To test switch S8, proceed as follows:

(1) Disconnect electrical connector J1 from control cubicle harness connector at back of control cubicle.

(2) Loosen three captive screws and open control panel.

(3) Tag and disconnect electrical wiring from switch. Test switch for continuity, refer to figure 4-32.

(4) If switch is faulty, replace switch. Reconnect wires.

(5) Connect electrical connector J1 to control cubicle.

c. Removal and Replacement. Remove and replace switch S8 as illustrated in figure 4-33.



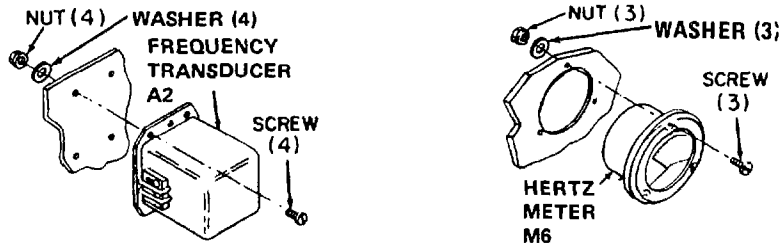

Figure 4-30. HERTZ Meter M6 and Frequency Transducer A2, Removal and Replacement

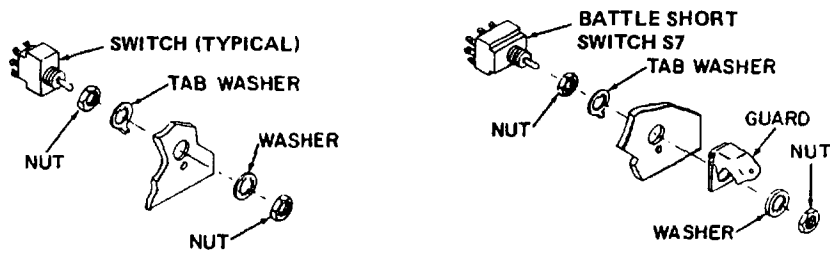
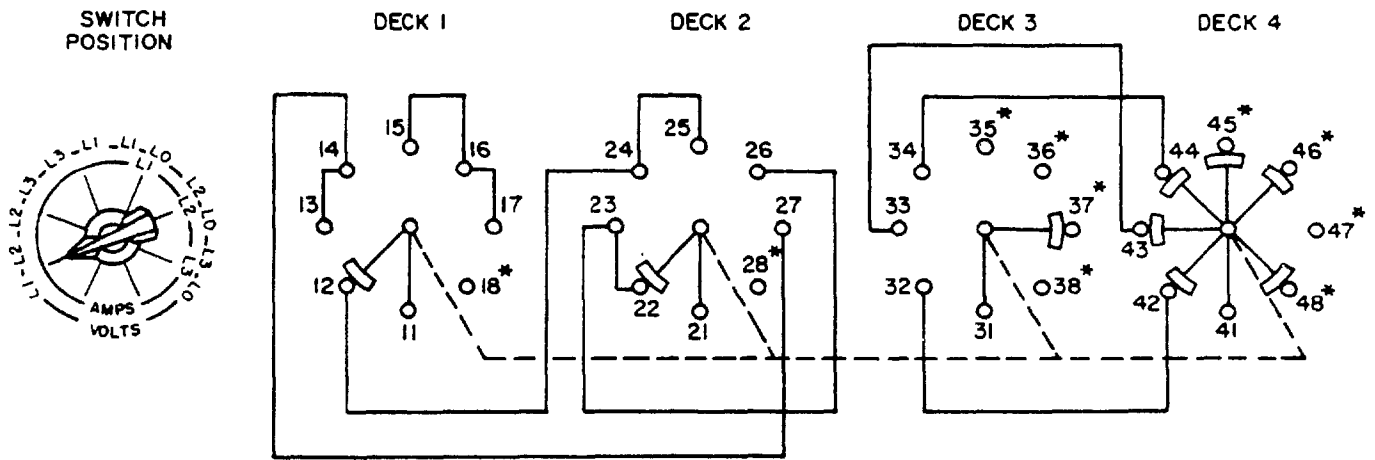

Figure 4-31. Toggle Switches, Removal and Replacement



\*CONTACTS NOT UTILIZED

Figure 4-32. AMPS-VOLTS Selector Switch S8, Simplified Schematic Diagram

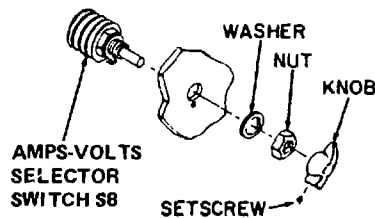

Figure 4-33. AMPS-VOLTS Selector Switch S8 Removal and Replacement

4-52. PANEL LIGHTS.

a. General. Panel lights DS1, DS2, and DS3 are controlled by PANEL LIGHT switch S4 and provide illumination when needed.

b. Replacement. Tag and disconnect wires to DS1, DS2, and DS3. Remove and replace panel lights as illustrated in figure 4-34.

4-53. INDICATOR LIGHTS.

a. General. The indicator lights are press-to-test indicators.

(1) AIR CLEANER CONDITION indicator DS8. The indicator is actuated by the air cleaner indicator switch and lights to indicate dirty air cleaner panel filters.

(2) BATTLE SHORT indicator DS7. The indicator lights when BATTLE SHORT switch is in ON position. It will remain lit until the switch is positioned to OFF.

(3) CKT BRK indicator DS6. The indicator lights when main circuit breaker is in the closed position.

b. Test. Unscrew lens assembly and remove lamp. Using an ohmmeter, check the continuity of the lamp: no continuity indicates a defective lamp. Replace lamp. Return lens assembly to its former position.

c. Replacement. Tag and disconnect leads to indicator lights. Remove or replace indicator lights as illustrated in figure 4-35.

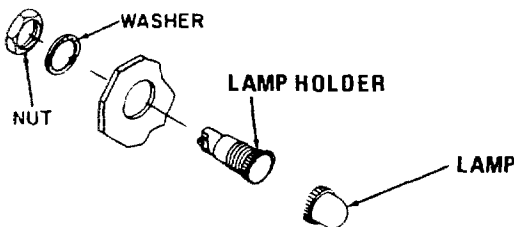

Figure 4-34. Panel Lights, Removal and Replacement

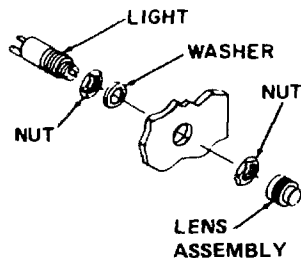

Figure 4-35. Indicator Lights, Removal and Replacement

4-54. OIL PRESSURE GAGE M1.

a. General. The oil pressure gage M1 is located on the engine portion of the generator set control panel. The gage works in conjunction with the oil pressure transmitter MT1 to display engine oil pressure in psig. M1 reads from 0 to 120 psig with scale divisions of 30 psig. As engine oil pressure increases or decreases, the resistance of the transmitter increases or decreases. Transmitter varying resistance is proportional to engine oil pressure and is transmitted to the oil pressure gage which converts the resistance to psig indications.

b. On-Equipment Test. To test M1, proceed as follows (refer to figure 4-36):

(1) Release three captive screws and open control panel.

**WARNING**

Do not touch exposed electrical connections with generator set operating.

(2) Start engine and permit engine to warm up. Measure voltage at gage IGN terminal, voltage should be 25 +/-5 V dc, if not check wiring back to source.

(3) Disconnect wire from SEND terminal and measure resistance between wire and ground, resistance should be approximately 15 ohms. Shut down engine.

(4) If above resistance value is obtained, replace gage.

(5) Close control panel and secure in place.

c. Replacement. Tag and disconnect leads on M1. Remove or replace M1 as illustrated in figure 4-37.

4-55. FUEL LEVEL GAGE M3.

a. General. The fuel level gage M3 is located on the engine portion of the generator set control

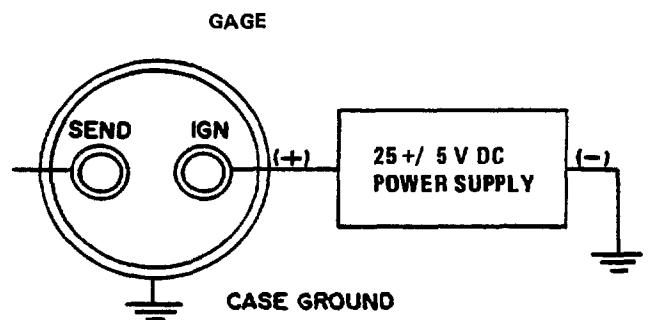
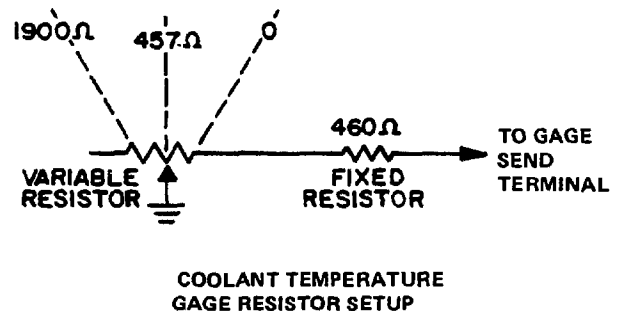
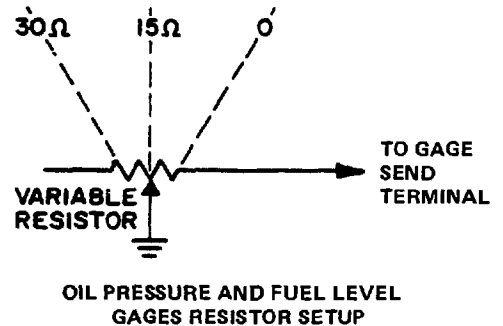

NOTE:  
 ALL RESISTANCE VALUES ARE ± 10%

Figure 4-36. Gage (Typical), Test Setup

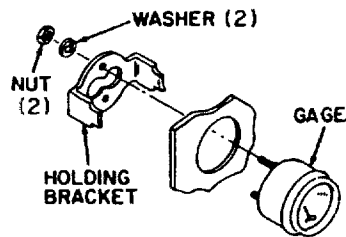

Figure 4-37. Gage (Typical), Removal and Replacement

panel. The gage works in conjunction with the fuel level transmitter MT3 located in the fuel tank. The gage is scaled from full to empty with scale divisions of 1/4 tank and indicates level of fuel in the fuel tank. As the level of fuel in the tank varies, the resistance of the transmitter varies. This varying resistance which is proportional to the level of fuel in the tank is transmitted to the fuel level gage which converts the resistance to fuel level indications.

b. On-Equipment Test.

(1) Release three captive screws and open control panel.

WARNING

Do not touch exposed electrical connections when DC CONTROL CIRCUIT BREAKER is energized.

(2) Energize DC CONTROL CIRCUIT BREAKER. Drain or add fuel to fuel tank until gage indicates 1/2 or FULL.

(3) Measure voltage at gage IGN terminal (see figure 4-37), voltage should be 25 +/-5 V dc, if not, check wiring back to source.

(4) Disconnect wire from SEND terminal and measure resistance between wire and to ground. Resistance should be approximately 30 ohms if tank is full or 15 ohms if tank is half full. De-energize DC CONTROL CIRCUIT BREAKER.

(5) If above resistance values are obtained, replace gage.

(6) Close control panel and secure in place.

c. Replacement. Tag and disconnect leads on M3. Remove or replace M3 as illustrated in figure 4-37.

4-56. COOLANT TEMPERATURE GAGE M2.

a. General. The coolant temperature gage M2 is located on the engine portion of the generator set control panel. The gage works in conjunction with the coolant temperature transmitter MT2 to display engine coolant temperature in degrees Fahrenheit. MS reads from 120° to 240°F (48° to 114°C). As engine coolant temperature increases or decreases, the resistance of the transmitter increases or decreases. This varying resistance which is proportional to engine coolant temperature, is transmitted to the coolant temperature gage which converts the resistance to degrees Fahrenheit indications.

b. On-Equipment Test.

(1) Release three captive screws and open control panel.

(2) Remove harness wire from gage SEND terminal and measure resistance between lead and ground, resistance should be greater than 2300 ohms. Reconnect wire.

WARNING

Do not touch exposed electrical connections with generator set operating.

(3) Start engine and permit engine to warm up to normal operating temperature. Measure voltage at gage IGN terminal and ground, voltage should be 25 +/-5 V dc, if not, check wiring back to source.

(4) Disconnect wire from send terminal of gage and measure resistance between wire and ground. Resistance should be approximately 917 ohms. Shut down engine.

(5) If above resistance values are obtained, replace gage.

(6) Close control panel and secure with captive screws.

c. Replacement. Tag and disconnect leads on M2. Remove and replace coolant temperature gage as illustrated in figure 4-37.

#### 4-57. BATTERY CHARGING AMMETER M4.

a. General. THE BATTERY CHARGING AMMETER M4 is located on the engine portion of the generator set control panel. M4 indicates battery charging current is scaled from -10 to +20 amperes with scale divisions of 1 ampere. The scale is color coded red and green; red indicates discharging operation, green charging.

b. Test. To test M4, proceed as follows:

(1) Connect a calibrated master ammeter in series with battery charging ammeter.

(2) Start and operate engine at rated speed.

(3) Monitor ammeters during starting and operation. Ammeter readings should be the same.

(4) Remove master ammeter. Replace defective M4.

c. Replacement. Tag and disconnect leads on M4. Remove and replace battery charging ammeter as illustrated in figure 4-28.

#### 4-58. RUNNING TIME METER M5.

a. General. The RUNNING TIME meter M5 is located on the engine portion of the generator set control

panel. The meter records the operating time of the generator set in hours and tenths up to 9999.9.

b. Test.

(1) Operate generator at rated speed for approximately 3 minutes.

(2) Using a watch, note indication on running time meter, and operate generator set for 30 minutes. Compare lapsed time on RUNNING TIME meter and watch; they should be the same.

(3) Shut down generator set. Replace defective meter.

c. Replacement. Tag and disconnect leads on M5. Remove and replace M5 as illustrated in figure 4-28.

#### 4-59. ENGINE MANUAL SPEED CONTROL.

a. General. The engine manual speed control permits coarse and fine control of engine speed (actually generator output frequency, directly related to engine speed, is monitored).

b. Test. To test manual engine speed control, proceed as follows:

(1) Depress locking button and slide control in and out to check that motion is free and that engine speed will vary in accordance with this motion.

(2) Rotate vernier (fine adjust) knob to increase (clockwise) or decrease (counterclockwise) engine speed and check that motion is free and that engine speed will vary in accordance with these adjustments.

c. Removal. To remove engine manual speed control, refer to figure 4-38, and proceed as follows:

(1) Remove screws (1) and nuts (2) to free rod end (3).

(2) Remove nut (4) and rubber sleeves (40 and 41).

(3) Loosen and remove nuts (33, 36, and 37), collar nut, and washers (34, 35, and 38).

(4) Remove throttle cable assembly (39).

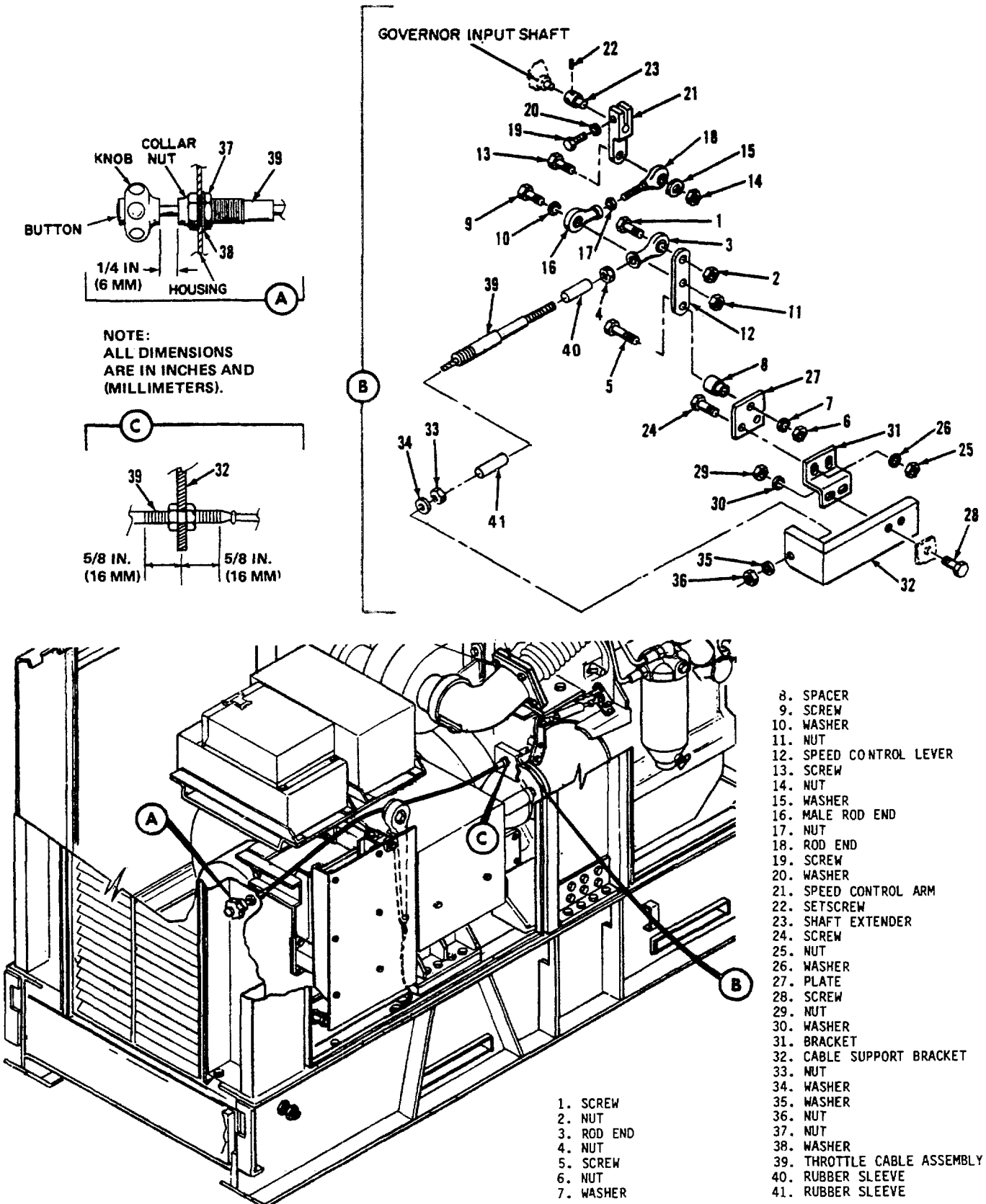

Figure 4-38. Manual Speed Control, Removal and Installation

(5) Remove screw (9), washer (10), and nut (11).

(6) Remove screw (13), washer (15), and nut (14) to free rod end (18).

(7) Remove screw (19), washer (20) to free speed control arm (21).

(8) Loosen setscrew (22) to free shaft extender (23).

d. Installation. Refer to figure 4-38 and install manual speed control and observe the following:

(1) Position throttle cable assembly (39) in housing and secure with nut (37) and washer (38). Install rubber sleeves (40 and 41).

(2) Position throttle cable assembly (39) in cable support bracket (32) as shown in detail C.

(3) When securing brackets (31 and 32) to lifting frame make sure that elongated holes in bracket (31) are centered on mounting screws.

NOTE

Do not connect speed control arm (21) to shaft extender (23) at this time.

(4) Adjust length of rod ends (16 and 18) to obtain a dimension of 2 inches (51 mm) center-to-center of rod end holes. Tighten nut (17).

NOTE

Do not tighten nut (4) at this time.

(5) Screw rod end (3) on throttle cable assembly (39) so that approximately ten threads of control are exposed.

(6) Adjust manual speed control as specified in step d.

e. Adjustment. To adjust manual speed control, refer to figure 4-38 and proceed as follows:

(1) Depress manual speed control button and pull out knob approximately 1/4 inch (6 mm) as shown in detail A of figure 4-38.

(2) Manually rotate governor input shaft to full counterclockwise position. Position speed control arm (21) on shaft extender (23) and tighten screw (19).

(3) Depress throttle cable assembly button and move control in and out. Check for any binding. Correct cause of binding before continuing adjustment.

(4) Start engine and permit engine to warm up.

CAUTION

When adjusting rod end (3), make sure a minimum of 1/4 inch (6 mm) of push-pull control is threaded into rod end.

NOTE

Use a strobe for determining engine speed.

(5) Depress throttle cable assembly button and push control all the way in while observing engine speed. Do not exceed engine speed of 2250 rpm. If engine speed exceeds 2250 rpm, the governor high speed stop is improperly adjusted: refer to next higher level of maintenance for corrective action. If engine speed does not reach 2250 rpm, shut down engine, remove screw (1), and turn rod end (3) counterclockwise, to extend length of assembly. Connect rod end (3) to speed control arm (12).

NOTE

If 2250 rpm engine speed can not be obtained after performing adjustments in step (6), the governor high speed stop is improperly adjusted: refer to next higher level of maintenance for corrective action.

(6) Start engine and recheck speed setting. Repeat adjustment procedure in step (5) until 2250 rpm is obtained. If engine speed of 2250 rpm is not obtained with a

minimum of 1/4 inch (6 mm) of throttle cable assembly (39) in rod end (3), turn nuts (33 and 36) clockwise to extend length of throttle cable assembly. Adjust rod end (3) and nuts (33 and 36) until 2250 rpm is obtained. If adjustment can not be obtained, loosen screws (28) and reposition bracket (31) to extend length of throttle cable assembly. Repeat above procedure to obtain 2250 rpm.

(7) Tighten nuts (4, 33, and 36). Recheck speed setting.

(8) Depress throttle cable assembly button and pull assembly all the way in. Engine speed should not be less than 1200 rpm. If engine speed is less than 1200 rpm, governor low speed stop is improperly adjusted: refer to next higher level of maintenance for corrective action.

#### 4-60. RELAY ASSEMBLY A4.

a. General. Relay assembly A4, which is mounted within the control box assembly, contains stop-run relay K1, remote voltage sensing relay K6, rectifier bridge CR1, and resistor R10.

b. Inspect. To inspect relay assembly A4, proceed as follows:

(1) Open the control box assembly front panel.

(2) Inspect relay assembly A4 for broken terminals, frayed wires, a burnt or charred resistor, cracked parts, and other signs of obvious damage.

(3) Close front panel and secure in position.

c. Replacement. To remove and replace relay assembly A4, proceed as follows:

(1) Open the control box assembly front panel.

(2) Tag and disconnect leads connected to A4 terminal boards.

(3) Remove four nuts and washers (located at the corners of A4 assembly) and remove A4.

(4) Replace assembly A4 by performing steps (1) through (3) in reverse order.

#### 4-61. SYNCHRONIZING LIGHTS DS4 AND DS5.

a. General. SYNCHRONIZING LIGHTS DS4 and DS5 are used when setting up two generator sets for parallel operation.

b. Inspect. Inspect the synchronizing lights DS4 and DS5 for damage. Check for security of electrical connections.

c. Test. To test DS4 and DS5, proceed as follows:

(1) Unscrew lens assembly from DS4 and DS5.

(2) Remove and check continuity of DS4 and DS5 lamps. Replace if lamp is burnt out.

(3) Install lamps and lens assembly.

d. Removal or Replacement. Tag and disconnect leads to DS4 or DS5. Remove and replace DS4 or DS5 as illustrated in figure 4-34.

#### 4-62. DOOR HOLDER.

a. General. When the control box panel opens downward and is held in place by two straps (door holders) which are secured between the front panel and the control box cabinet.

b. Inspect. Inspect the door holder for damage, fraying, and/or corrosion.

c. Replacement. To remove either of the two door holders, unhook one end of the door holder from the control box cabinet and unscrew the other end from the front panel. The panel door is removed by removing screws and washers from the door. Replacement is the reverse of removal.

#### 4-63. CROSS PINS.

a. General. The fastening device that secures the control box assembly front panel to the control box cabinet is held in place by a cross pin.

b. Inspect. Inspect the cross pins for damage and corrosion.



c. Replacement. Using a pair of pliers, remove cross pin. To replace cross pin, tap in with small hammer.

#### 4-64. WIRING HARNESSSES.

a. General. There are two wiring harnesses in the control box assembly: one that connects components of the control box assembly to connector J1; and a second that interconnects the various components of the control box assembly.

b. Test. To test wiring harnesses, proceed as follows:

(1) Release locking devices that secure control box assembly front panel and open front panel.

(2) Using a multimeter, check the continuity of both wiring harnesses (refer to FO-1 and FO-2 the AC and DC Troubleshooting Diagrams).

c. Replacement. To remove or replace wiring harnesses, proceed as follows:

(1) Release locking devices that secure control box assembly front panel and open front panel.

(2) Tag and disconnect all leads between components and between components and connector J1.

(3) Remove four screws and nuts that secure connector J1 to rear wall of control box.

(4) Remove both wiring harnesses.

(5) Replace both wiring harnesses by performing steps (1) through (4) in reverse order.

#### NOTE

When installing connector J1 make certain that key way is on top.

#### 4-65. OIL PRESSURE TRANSMITTER MT1.

a. General. Oil pressure transmitter MT1 is installed in the lubricating oil system and is electrically connected to the OIL PRESSURE gage M1. As engine oil pressure increases or decreases, the resistance of the transmitter

increases or decreases. This varying resistance, which is proportional to engine OIL PRESSURE, is transmitted to the oil pressure gage which converts the resistance to psig indications.

b. Inspect. Inspect the oil pressure transmitter MT1 for obvious damage and security of electrical connections.

c. On-Equipment Test. To test MT1, proceed as follows:

(1) Refer to figure 4-19 and remove lead from oil pressure transmitter MT1.

(2) Using multimeter, measure resistance from transmitter to ground: resistance should be 0 to 1.0 ohm.

(3) Start and operate engine at rated speed. Recheck resistance of transmitter, resistance should be approximately 15 ohms with engine oil pressure at 60 psig.

(4) Shut down engine. If resistance does not vary, MT1 is defective. Replace defective transmitter and reconnect lead.

d. Removal. Remove oil pressure transmitter MT1 as illustrated in figure 4-19. Plug engine opening after removing MT1.

e. Installation. Install MT1 as illustrated in figure 4-19. Apply thread sealing compound per MIL-S-45180, Type III, to pipe threads prior to installation.

#### 4-66. COOLANT TEMPERATURE TRANSMITTER MT2.

a. General. Coolant temperature transmitter MT2 is installed in the engine cooling system and is electrically connected to the COOLANT TEMPERATURE gage. As engine coolant temperature increases or decreases, the resistance of the transmitter increases or decreases. This varying resistance, which is proportional to engine coolant temperature, is transmitted to the COOLANT TEMPERATURE gage which converts the resistance to degrees Fahrenheit.

b. Inspect. Inspect the coolant temperature transmitter MT2 for obvious damage and security of electrical connections.

c. On-Equipment Test. To test MT2, proceed as follows:

NOTE

Test should be accomplished on cold engine.

(1) Refer to figure 4-19 and remove lead from coolant temperature transmitter MT2. Measure resistance through transmitter to ground, resistance should exceed 2.4 K ohms.

NOTE

Observe radiator shutter to determine temperature. Shutter vanes will start to open at 158°F (69.3°C).

(2) Start and operate engine until approximate normal operating temperature is obtained (180°F, 81.4°C). Recheck resistance, resistance should decrease to approximately 900 ohms.

(3) Shut down engine. Drain approximately one-half of coolant from engine. Replace defective transmitter and reconnect lead.

d. Removal. Remove coolant temperature transmitter MT2 as illustrated in figure 4-19. Plug engine opening after removing MT2.

e. Installation. Install coolant temperature transmitter as illustrated in figure 4-19. Apply thread sealing compound conforming to MIL-S-45180, Type III to pipe threads prior to installation.

#### 4-67. FUEL LEVEL TRANSMITTER MT3.

a. General. Fuel level transmitter MT3 is installed in the set fuel tank and is electrically connected to the FUEL LEVEL meter. As fuel level increases or decreases, the resistance of the transmitter

increases or decreases. This varying resistance, which is proportional to fuel level, is transmitted to FUEL LEVEL meter where a relative indication of fuel tank status is presented.

b. Inspect. To inspect MT3, refer to figure 4-19 and proceed as follows:

(1) Disconnect and tag lead to MT3.

(2) Remove five screws securing MT3 to mounting plate and carefully take out fuel level transmitter.

(3) Gently shake float at bottom of MT3 to check for presence of fuel in float. Replace MT3 if there is fuel in float.

(4) Check MT3 for cracks and obvious signs of damage.

c. Test. To test MT3, proceed as follows:

(1) Connect multimeter (set to measure low ohms) between terminal and metal screw hole on mounting flange of MT3.

(2) While holding body of MT3, gently swing float from its resting position to its full up position while observing multimeter.

(3) Resistance reading of multimeter should rise smoothly from 0.00 (approximately) ohms to 30 +/-1.5 ohms (full up position of float).

(4) Observe that float, at full (up) is 0.44 to 0.50 inch (11.17 to 12.7 mm) and, at empty (down) is 7.50 to 7.62 inches (190.5 to 193.5 mm) from bottom of MT3 flange. Bend float support, using a long-nose pliers, until dimensions are correct.

d. Replace. To replace MT3, proceed as follows:

(1) Using pliers, adjust float level to meet requirements outlined in test procedure above.

(2) Position gasket under MT3 flange.

(3) Carefully insert MT3 into position at top of mounting plate.

(4) Secure MT3, with five screws, to mounting plate.

(5) Reconnect electrical lead to MT3.

## Section XI. MAINTENANCE OF AC ELECTRICAL CONTROL SYSTEM

4-68. GENERAL. The purpose of the engine generator set is to produce an electrical output. To accomplish this end, an AC 3-phase, brushless-type generator is directly coupled to the diesel engine. The AC electrical control system monitors and controls the generator to ensure that a constant output in terms of amplitude is maintained under all permissible load conditions and modes of operation. The frequency and phase of this output is controlled indirectly by controlling engine speed. The following paragraphs explain the various functions of this control system and are referenced to FO-4, the AC schematic diagram. Paragraphs 4-69 through 4-82 provide organizational maintenance procedures for the AC electrical control system.

a. Single Unit Operation. Once the engine has stabilized and is running normally, the load may be applied to the main generator G1 output terminals through the heavy duty contacts of circuit breaker CB2. When CKT BRK switch S3 is toggled to the CLOSED position, 24 V dc is applied through a protective circuit, consisting of relay contacts K14, K15, and K13, to relay K26 (part of main circuit breaker CB2). When K26 energizes, one set of its contacts opens. A second set closes to connect 24 V dc to a two-way motor, an integral part of CB2. This motor, through mechanical linkages, closes both the main and three sets of auxiliary CB2 contacts. The purpose of relay UV is to ensure that if DC CONTROL CIRCUIT BREAKER CB1 is used to shut down the generator set during an emergency situation, main circuit

breaker CB2 will disconnect despite the loss of 24 V dc. Initially, when CB2 operates, its contacts are spring-loaded into the closed position and held in place by the action of relay UV. When UV deenergizes, these contacts are allowed to spring open and quickly disconnect the generator from the load circuits.

The first set of auxiliary CB2 contacts, connected across S3, serve to latch K26 in the energized state when switch S3 is released. The second set connects 24 V dc to CKT BRK indicator DS6 which lights to inform the operator that the main circuit breaker has closed. The remaining auxiliary contacts connect the output of reactive current adjust rheostat R29 to exciter-regulator assembly A11.

With the AC output now applied to the load, generator G1 output must be maintained at the required voltage. This output is indirectly controlled by the amount of current flowing in the generator's exciter field. The voltage to be regulated is sensed either locally or remotely as determined by switch S2. VOLTAGE SENSING switch S2, when set to LOCAL, connects the generator output from the voltage change board to the input of exciter-regulator assembly A11. VOLTAGE ADJUST control R2 acts to increase or decrease the output voltage by varying the amount of voltage fed back to A11. With S2 set at REMOTE, the output voltage is now sensed at the load circuit by energizing dc relay K6; bridge rectifier CR1 converts 120 V ac to the dc voltage necessary to operate K6. The contacts of K6 switch the sensing

path from the generator (local) to the load (remote).

The exciter voltage regulator A11 (see F0-6) are integral components of the excitation system. The excitation system energizes the main rotor field coils of the generator and regulates the generator output under all rated load conditions. The excitation system is comprised of a dynamic exciter, a static exciter assembly, a voltage regulator assembly, current transformers, and, to permit parallel operation, a cross-current compensation network.

(1) The static exciter and voltage regulator are electronic assemblies packaged in a single enclosure and mounted outside the generator housing.

(2) The dynamic exciter consists of a field coil stator (mounted inside the generator housing), a set of rotor coils and solid-state rectifiers mounted on the generator shaft. The static exciter energizes the field coils of the dynamic exciter. The resultant magnetic field induces currents into the rotor coils which are then rectified and fed to the generator rotor. The magnetic field of the generator rotor induces an output current in the generator stator. The exciter-regulator circuitry is illustrated in F0-6 and operates as follows:

(a) The regulated exciter field voltage at pins S-R of connector J13 is controlled by means of saturable core transformer T1. The mutual inductance of this transformer can be varied with the control winding 5-7 so that the amount of coupling between the windings 1-2 and 3-4 may be increased or decreased in proportion to the direct current flowing in the winding 5-7. When the control current increases, the mutual inductance decreases. There is less coupling and a lowered voltage output. The reverse occurs when the control current is decreased.

(b) The input at J-K of connector J13 derives from current transformers CT4, CT5, CT6, placed around the load cables of the generator. The voltage at L-M of connector J13 is from phase C (T9 - T12 on generator). The two inputs are combined by T1 under control of winding 5-7, then rectified by bridge CR1 through CR4 and fed to the exciter field stator winding from S-R of connector J13. In the event of a short circuit, the voltage at L-M can drop to zero. However, there is a high voltage at J-K from the current transformers so that the exciter provides sufficient field for the generator output to actuate the protective devices to shut down the set.

(c) The voltage at S-R of connector J13 is compared to the reference voltage at Q1 (located in voltage regulator A10) and zener diode VR1 of the differential amplifier Q1 - Q2. Any difference (error signal) at the collector of Q2 is amplified by Q5 - Q6 and Q3 - Q4 and then fed to the control winding 5-7 of the control transformer T1 which increases or decreases the exciter field coil current to return the error signal to zero. Thus the output of the generator set is maintained within the range set by R33. The networks R31-C1 and R32-C3 are utilized for phase shift compensation. If hunting is present, adjustment of R32 will provide the proper amount of feedback to eliminate the hunting. Adjustment of R31 will smooth and improve the transient response.

(d) The voltage at pins A-B of connector J9 is derived from phase C (T9 - T12 on generator) through the operator's VOLTAGE ADJUST control and (when generator sets are connected in parallel) from the cross-current compensation network. This voltage is stepped down in transformer T5, rectified by bridge CR12 - 15, filtered by R16, R22, C2, C5 and fed to the reference side of the differential amplifier Q1 - Q2.

(e) The generator output voltage is determined by the level of the reference voltage and by the settings of R33 and the VOLTAGE ADJUST control. During parallel operation, the reference voltage is dependent on the cross-current compensation network. For example, if one generator draws more current, the network will increase the magnitude of the reference voltage causing the voltage regulator to sense more voltage thereby causing a decrease in current to the exciter field stator winding. This provides parallel operation with droop.

(f) Power for the transistor amplifiers and the control winding (5-7) of T1 is obtained from pins L-M of connector J13 through stepdown transformer T4 and bridge rectifier CR8 through CR11. Diode CR17 and resistor R21 provide positive feedback to the amplifiers to enhance the gain.

(g) When the generator set is started, 24 V dc is momentarily applied to the exciter field stator windings at pins S-R of connector J13 through limiting resistors R17A, R17B, and isolation diode CR16 from input pins C-D of connector J11. The purpose of this is to quickly build up the magnetic field (field flashing) in the main rotor windings to produce an immediate output from the generator.

b. Parallel Operation. To increase the total available power, the generator set may be operated in parallel with as many as two additional generator sets. For paralleling to work, the phase sequence, phase, frequency, and amplitude of the generator set outputs must be made to coincide. The amplitudes are made to correspond by manually adjusting and comparing the outputs of each generator set. Phase sequence is accomplished by properly connecting the generator sets that are to be paralleled. Therefore, with both sets properly connected and the main circuit breaker of the incoming

generator set open, the PARALLEL OPERATION-SINGLE UNIT OPERATION switch S6 of the incoming set is positioned to PARALLEL OPERATION. With S6 set to PARALLEL OPERATION, SYNCHRONIZING LIGHTS DS4 and DS5 are connected between the outputs of both generator sets through dc relay assembly A5: A5 serves only to protect DS4 and DS5 from burning out. If the outputs of both generator sets are in phase, the voltage difference across both DS4 and DS5 will be zero. As a result, neither DS4 or DS5 will light. If, however, the generator set outputs are out of phase, a voltage difference will appear across DS4 and DS5 and both will light. How intensely they will light depends on the extent of this voltage difference. When the frequency of one engine generator set is not coincident with the other, the extent of the voltage difference will vary at a continuous rate (proportional to the difference in frequencies) and the light intensity of DS4 and DS5 will increase and decrease in a corresponding manner.

If the generator sets are set for a 240/416 voltage output, the voltage difference between the two sets can go as high as 240/416 volts and DS4 and DS5 would burn out. To avoid this, resistors R6 and R9 (located on relay assembly A5) are placed in series with DS4 and DS5. However, if the generator sets are set for 120/208 volts, these resistors would cause too much of a voltage drop and prevent DS4 and DS5 from lighting. When the generator sets are set for an output of 120/208, the contacts of parallel-lights-voltage-sensor relay K7 bypass resistors R6 and R9. Relay K7 is energized by rectifier CR4 only when the generator set output is 120/208 volts.

c. Generator Faults. As a means of either protecting the generator set and/or the load, various fault-sensing devices are included in the AC electrical control system. The electrical output of the generator set

will disconnect from the load if any one of three malfunctions occur: the load short-circuits; the load draws an excessive amount of current (overload); and if, during parallel operation, power from one generator set feeds into another generator set. If any of these faults occur, a relay energizes and removes 24 V dc operating power from main circuit breaker CB2.

(1) Short Circuit

Protection. In the event of a short circuit, the generator, to protect it from damage, is immediately disconnected from the load. Short circuit relay K13, consisting of three coils, is connected across current transformers which monitor current flow in each of the three generator output phases. If a short circuit occurs, excessive current will flow in one of three current transformers CT1, CT2, or CT3. This excessive current is sufficient to trigger K13, whose contacts then open. These contacts are in series with 24 V dc and main circuit breaker CB2 and, when they open, deenergize CB2. With K13 energized, a second set of its contacts close to activate the fault indicator circuits, and the SHORT CIRCUIT indicator lights.

(2) Overload Protection.

If the output current of any phase winding of G1 exceeds an amount that might be harmful to generator G1, thermal relay K14, after a short period of time (about 8 minutes), activates. Consequently, the normally closed contacts of K14 open to interrupt the 24 V dc to main circuit breaker CB2. As before, when this occurs, the generator output is immediately disconnected from the load. Generator G1 is capable of safe operation while overloaded for short periods of time. This accounts for the delayed operation of K14. When K14 energizes, a second set of its contacts close to activate the fault indicator circuits, as a result the OVERLOAD indicator lights.

NOTE

Because 24 V dc is necessary to operate relay K14, its coil is redrawn in FO-5, the DC electrical schematic diagram, to show this required connection.

(3) Reverse Power

Protection. While in a parallel mode of operation, an out-of-phase or low voltage condition could cause the current of one generator to feed the second generator. Such a condition might either burn out the second generator or cause it to "motor" (the generator functions as a motor).

Relay K15, operating in conjunction with the load measuring unit (LMU), activates upon sensing a reverse-power condition and its normally closed contacts open. Subsequently 24 V dc is disconnected from main circuit breaker CB2. With 24 V dc removed from CB2, its main contacts open and disconnect the generator set from the load. When K15 energizes, a second set of its contacts close to activate the fault indicator circuits, as a result, REVERSE POWER indicator lights.

NOTE

Because 24 V dc is necessary to operate relay K15 (as it was with K14), its coil is also redrawn in FO-5, the DC electrical schematic diagram, to show this required connection.

d. Miscellaneous. The following paragraphs briefly describe those circuits not directly related to the operation and use of the generator.

(1) Load Measuring Unit A8. The load measuring unit A8, measures the total load on the generator set regardless of power factor or phase and produces a dc voltage proportional to this load.

(2) Thermal Watt Converter A1 and KILOWATTS Meter M7. Power (in kilowatts) is measured by KILOWATTS meter M7 in conjunction with thermal watt converter A1. A1 produces a dc output which is proportional to the product of generator output voltage and current (power). This dc output is applied to meter M7 which directly indicates this computed power as a percentage of rated power. Because rated power, in this case is 100 KW, the meter essentially reads out in kilowatts as well as percent.

(3) Frequency Converter A2 and CYCLES Meter M6. Output frequency is monitored by a circuit consisting of frequency converter A2 and CYCLES meter M6. A2 produces a dc voltage whose value corresponds to the frequency of the generator set output. This dc voltage is applied to and displayed by meter M6 as the output frequency in Hertz (cycles per second).

(4) VOLTS AC Meter M9, PERCENT RATED CURRENT Meter M8, and AMPS-VOLTS Selector Switch S8. The voltage and current must be continually monitored to ensure proper use of the generator. The voltage and current are measured by meter M9 and M8, respectively, and switched, as required by switch S8 from one generator winding to another. Paragraphs 4-69 through 4-81 provide maintenance procedures for the various components of the AC electrical control system.

#### 4-69. TACTICAL RELAY ASSEMBLY A29.

a. General. The tactical relay assembly A29 contains overvoltage relay K2, reverse power relay K15, short circuit relay K13, and overload relay K14.

b. Inspect.

(1) Remove the four screws and washers securing the cover of the tactical relay assembly A29 and remove cover.

(2) Inspect wiring harness for loose connections, frayed insulation, breaks, and exposed terminals that may be close to or actually touching each other. Inspect for signs of obvious damage.

(3) Reinstall and secure cover with four screws and washers removed in step (1).

#### 4-70. MODE I RELAY ASSEMBLY A27.

a. General. Mode I relay assembly A27 contains DC relay assembly A5, cross-current transformer T1, variable resistor R29, a shorting plug, engine crank relay K3, battery charging ammeter shunt R13, and interconnecting harnesses.

b. Inspect.

(1) Remove screws and washers securing the cover of Mode I relay assembly A27 and remove cover.

(2) Inspect wiring harness for loose connections, frayed insulation, breaks, and exposed terminals that may be close to or actually touching each other. Inspect also for signs of obvious damage.

#### 4-71. RECONNECTION BOARD ASSEMBLY.

a. General. The reconnection board assembly is equipped with a voltage change board to permit easy conversion to 120/208 or 240/416 generator output voltage. Positioning of the voltage change board connects two coils of each phase in series or parallel: in parallel the output is 120/208; in series the output is 240/416 V ac. The terminals on the reconnection board assembly that are connected to the generator load circuits are numbered according to the particular coil end of each phase of the generator to ensure proper connections.

b. Removal. Refer to figure 4-39 and remove the reconnection board as follows:

LEGEND

1. STUD
2. CROSS PIN
3. PROTECTIVE COVER (WITH WRENCH ASSEMBLY)
4. SCREW
5. NUT
6. BRACKET
7. BRACKET
8. SUPPORT BRACKET
9. NUT
10. WASHER
11. ELECTRICAL LEAD
12. CABLE
13. RECONNECTION BOARD ASSEMBLY
14. SCREW
15. LOCKWASHER
16. WASHERS
17. LOAD BOARD ASSEMBLY
18. NUT
19. LOCKWASHER
20. LOAD TERMINAL
21. SCREW

- 
22. NUT
  23. WASHER
  24. LEAD
  25. NEUTRAL BUS BAR
  26. TERMINAL BOARD

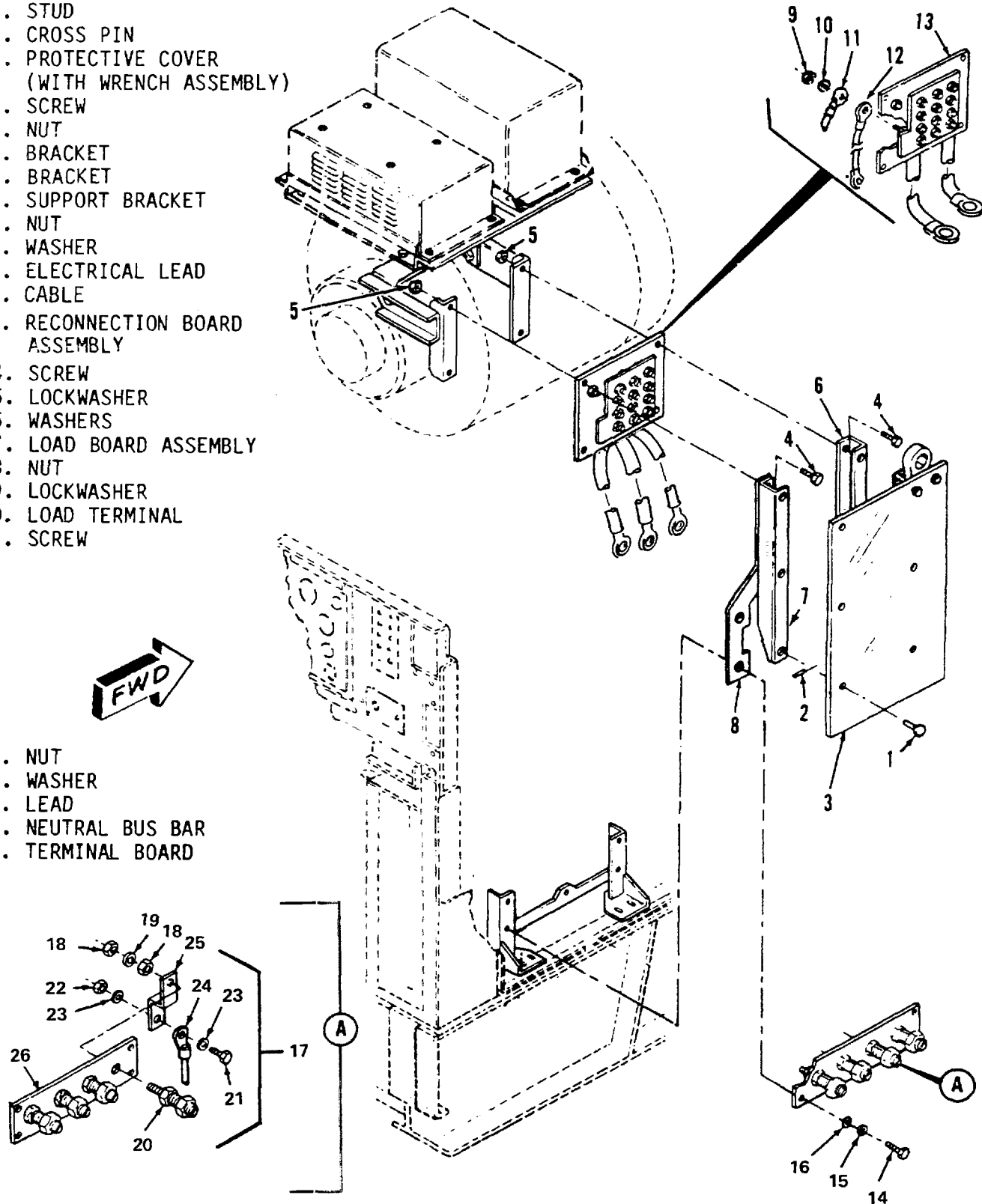

Figure 4-39. Reconnection Board Assembly and Load Board Assembly, Removal and Installation



(1) Remove protective cover (3) by removing loosening studs (1).

(2) Remove brackets (6 and 7) by removing screws (4) and nuts (5).

(3) Remove support bracket (8) by removing screws (14), lockwashers (15), and washers (16).

#### NOTE

Tag electrical leads with location to ensure proper installation.

(4) Remove nuts (9), washers (10), electrical leads (11), and cables (12) from reconnection board assembly (13).

c. Disassembly. Refer to figure 4-40 and disassemble reconnection board as shown. Pay particular attention to the fact that each stud is numbered, note numbering sequence prior to removal to ensure proper assembly.

#### WARNING

All cleaning compounds that meet MIL-C-87937 may be toxic. Avoid prolonged or repeated breathing of

vapor or contact with skin. Avoid any contact with eyes. Safety glasses and protective gloves are required. Wash hands after use. Refer to applicable MSDS for additional information.

#### NOTE

MIL-C-87937, Types II and IV cleaners must be diluted with water before use. Type III cleaners can be used full strength or diluted. All MIL-C-87937 products must be rinsed off after cleaning. The cleaning solutions may be more effective if heated. Follow manufacturer's instructions and cautions for specific product used.

d. Cleaning. Clean components using MIL-C-87937 as follows:

(1) Dilute Types II or IV cleaners according to amount of soil to be removed: minimum dilution required is 2:1 (2 parts water: 1 part cleaner). Normal dilution ratios are 4:1 for heavy soils and 10:1 for light soils. Type III cleaners can be used full strength or diluted as desired.



(2) Heat cleaning solution if desired, following manufacturer's instructions and cautions.

(3) Use a clean, lint-free cloth to apply the cleaning solution and to clean the components.

(4) When components are clean, rinse thoroughly with water.

(5) After cleaning and rinsing components, dry thoroughly.

e. Inspection.

(1) Inspect threads for damage.

(2) Inspect terminal board and bus bars for cracks, warping, and burnt spots.

(3) Inspect for broken electrical leads caused by lockwashers cutting into the leads due to missing flat washers.

f. Repair. Repair by replacing defective studs and/or bus bars.

g. Reassembly. Refer to figure 4-39 and reassemble reconnection board assembly. Ensure studs are installed in proper numbering sequence.

h. Installation. Refer to figure 4-39 and install reconnection board assembly as follows:

(1) Connect electrical leads (11) and cables (12), washers (10), and nuts (9) to reconnection board assembly (13) studs.

(2) Position reconnection board assembly (13), support bracket (8), and brackets (7 and 6) into mounting position on generator, and secure with screws (4 and 14), nuts (5), lockwashers (15), and washers (16).

(3) Install protective cover (3) and secure by tightening studs. Do not overtighten.

4-72. MAIN CIRCUIT BREAKER ASSEMBLY CB2.

a. General. The output terminals at the reconnection board assembly are connected to the circuit breaker with cable assemblies. The circuit breaker has three main contacts which serve to connect or disconnect the load from the generator three-phase, 4 wire, Y-connected output. Three cables from the circuit breaker assembly are connected to the load terminal board.

b. Inspect. Inspect CB2 and associated wiring harness for frayed insulation; and check electrical connections for tightness.

c. Test.

(1) Disconnect electrical connector from circuit breaker relay box connector J41. Connect a voltmeter across pins M and B with B negative. Energize DC control circuit breaker. There should be approximately 24 volts.

(2) Connect a voltmeter across pin A and B of J41. Set START-STOP-RUN and BATTLE SHORT switch to ON.

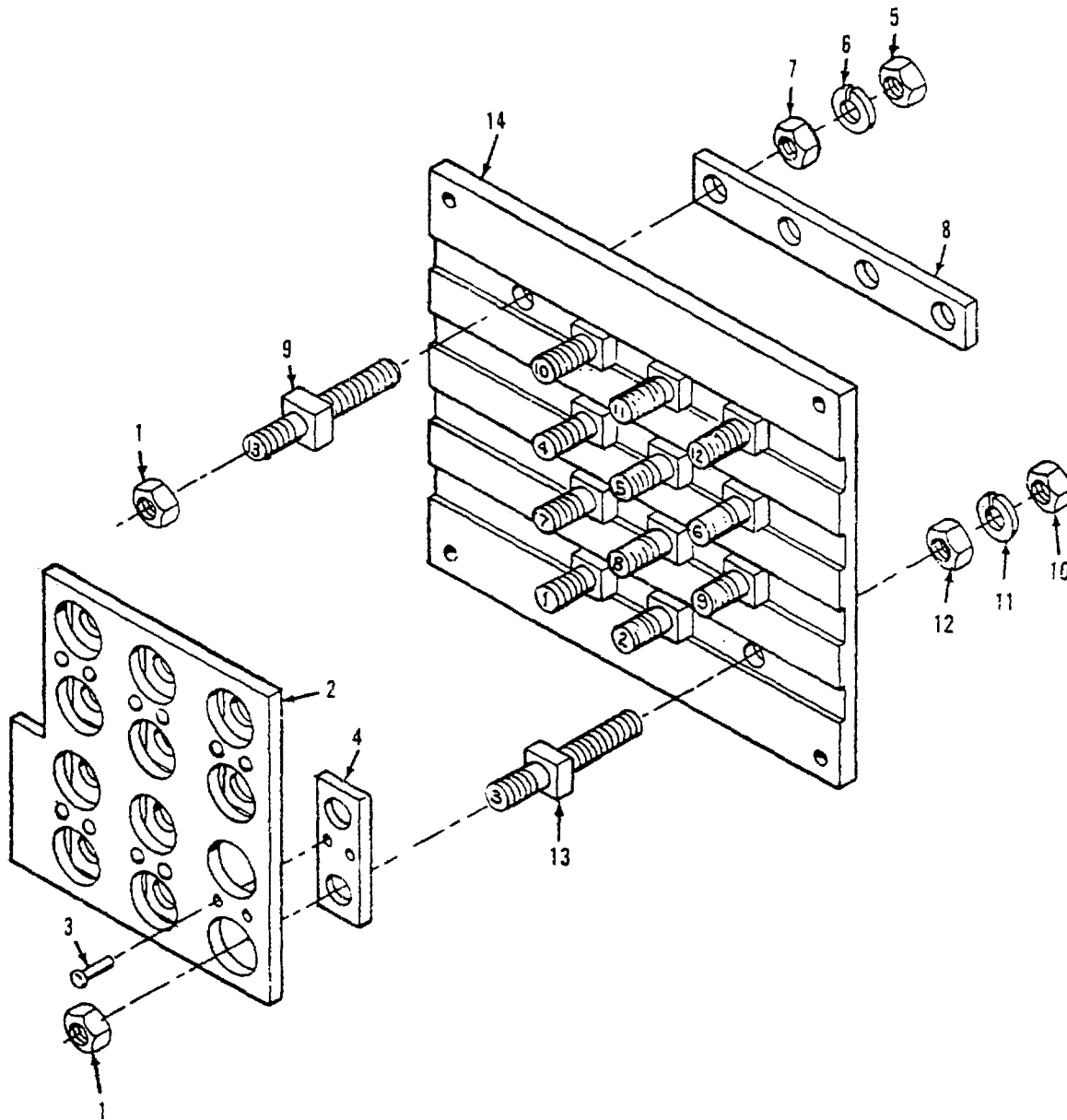

LEGEND

- |                                   |                    |
|-----------------------------------|--------------------|
| 1. NUT                            | 8. BUS BAR         |
| 2. VOLTAGE CHANGE BOARD           | 9. STUD            |
| 3. RIVET                          | 10. STUD NUT       |
| 4. BUS BAR                        | 11. STUD WASHER    |
| 5. NUT                            | 12. STUD NUT       |
| 6. TERMINAL BOARD ASSEMBLY WASHER | 13. STUD           |
| 7. NUT                            | 14. TERMINAL BOARD |

Figure 4-40. Reconnection Board Assembly, Exploded View

(3) Set CKT BRK switch to CLOSE; voltmeter should indicate approximately 24 volts.

(4) If voltage is not present in either step (2) or (3), check wiring back to its source and correct malfunction.

(5) If voltage is present but the contactor still will not close, refer repair of CB2 to next higher level of maintenance. Check CKT BRK indicator by depressing indicator; light should come on. If not, replace bulb.

(6) If the contactor closes and will not stay in the closed position, refer repair of CB2 to next higher level of maintenance.

(7) Position CKT BRK switch to OPEN, BATTLE SHORT switch to OFF, and START-STOP-RUN switch to STOP. Deenergize circuit breaker.

(8) Install connector plug P41 to circuit breaker relay box.

d. Removal. Refer to figure 4-41 and remove circuit breaker assembly as follows:

**NOTE**

Tag electrical leads with location to ensure proper reinstallation.

(1) Remove access doors (refer to Paragraph 4-21) and air intake louvers (refer to paragraph 4-26) for access to rear of circuit breaker assembly.

**NOTE**

If necessary, either or both of the following may be performed

(a) Remove convenience receptacle assembly (refer to paragraph 4-78b) for access to rear of circuit breaker assembly (7).

(b) Remove four locknuts on motor control box and remove motor control box.

(2) Remove connector P41.

(3) Tag and disconnect three cables and two electrical leads from top circuit breaker connections by removing screws (1), lockwashers (2), and extenders (3).

(4) Tag and disconnect three cables from bottom circuit breaker connections by removing screws (4), washers (5), and locknuts (6).

(5) Remove screws (7 and

10), lockwashers (8 and 11), and washers (9 and 12) and remove circuit breaker assembly (13).

**NOTE**

If either or both the convenience receptacle, assembly or motor control box, have been removed they must now be reinstalled.

e. Installation. Refer to figure 4-41 and install circuit breaker assembly. Pay particular attention to the following:

(1) Place circuit breaker assembly (13) onto bracket (14) and install washers (9 and 12) lockwashers (8 and 11), and screws (7 and 10).

(2) Connect three cables to bottom circuit breaker connections with screws (4), washers (5), and locknuts (6).

(3) Connect three cables and two electrical leads to top circuit breaker connections with screws (1), lockwashers (2), and extenders (3).

(4) Install connector P41.

(5) Install convenience receptacle assembly (refer to paragraph 4-78h).

**4-73. LOAD TERMINAL BOARD.**

a. General. The load terminal board has four terminals which are marked L1, L2, L3, and L0. Terminals L1, L2, and L3 are connected through cabling bus bars, and the circuit breaker assembly to generator output leads T1, T2, and T3, respectively.

b. Removal and Disassembly. Refer to figure 4-39 and remove and disassemble load board assembly as follows:

(1) Remove protective cover (3) by loosening studs (1).

(2) Disconnect load board assembly (17) by removing screws (14), lockwashers (15), and washer (16).

(3) Disconnect lead (24) from bus bar (25). Tag and disconnect circuit breaker cables from load terminals (20) by removing nuts (18) and washers (19).

**NOTE**

Note position of terminals prior to removal to ensure proper installation.

(4) Remove load terminals (20) and bus bar (25) from terminal board (26) by removing nuts (18).

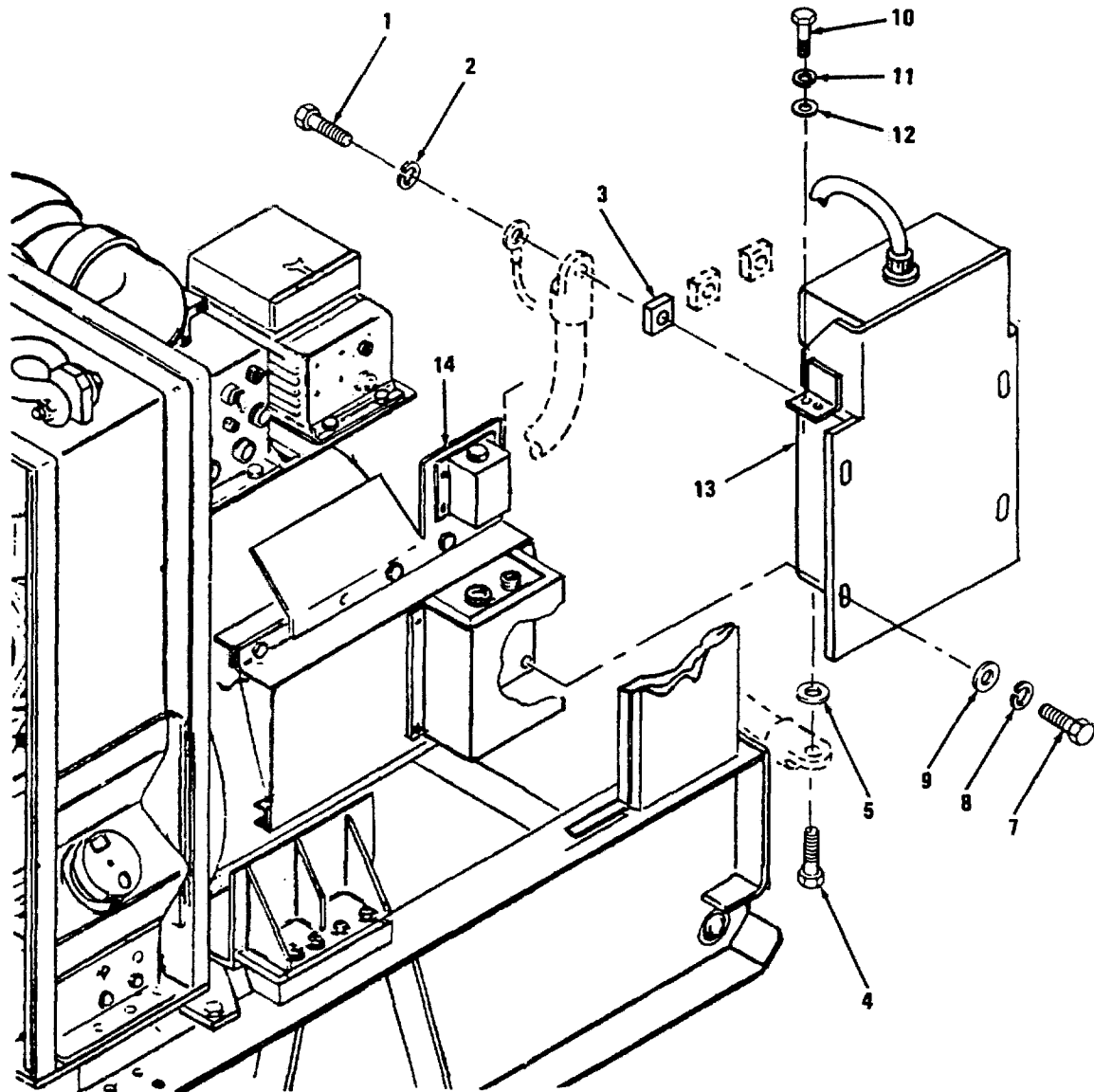

LEGEND

- |               |  |
|---------------|--|
| 1. SCREW      | 9. WASHER                                      |
| 2. LOCKWASHER | 10. SCREW                                      |
| 3. EXTENDER   | 11. LOCKWASHER                                 |
| 4. SCREW      | 12. WASHER                                     |
| 5. WASHER     | 13. MOTOR OPERATED CIRCUIT<br>BREAKER ASSY CB2 |
| 6. DELETED    | 14. BRACKET                                    |
| 7. SCREW      |  |
| 8. LOCKWASHER |  |

FIGURE 4-41. Circuit Breaker Assembly CB2, Removal and Installation

WARNING

Dry cleaning solvent, P-D-680, Type II, is flammable and moderately toxic to the skin, eyes, and respiratory tract. Skin, eye, and respiratory protection is required.

c. Cleaning. Clean parts cleaning solvent (P-D-680, Type II) and dry thoroughly.

d. Inspection.

(1) Inspect threads for damage.

(2) Inspect terminal board for cracks, warping, and burnt areas.

e. Reassembly and Installation. Refer to figure 4-39 to reassemble and install load board assembly as follows:

(1) Position load terminals (20) and bus bar (25) on terminal board (26) and secure with nuts (18).

(2) Connect lead (24) to bus bar (25) and secure with screw (21), nuts (18), and washers (19). Connect circuit breaker cables to load terminals (20) and secure with nuts (22) and washers (23).

(3) Position load board assembly (17) on bracket and secure with screws (14), lockwashers (15), and washers (16).

(4) Install protective cover (3) and secure by tightening studs (1).

4-74. PROTECTIVE RELAYS K2, K13, K14, AND K15.

a. General. Overvoltage relay K2, short circuit breaker relay K13, overload relay K14, and reverse power relay K15 are all located in tactical relay assembly A29.

b. Inspection. After disconnecting negative battery lead, inspect each of the protective relays as follows:

(1) Remove the four screws and washers securing the cover of the tactical relay assembly A29 and remove cover.

(2) Inspect relays for cracked or burnt terminal boards, signs of blistered paint, and loose or bent terminals. Inspect, also, for any signs of obvious damage.

(3) Reinstall and secure cover with four screws and washers of step (1).

4-75. CONTROL RELAYS K1 AND K6.

a. General. Stop-run relay K1 and remote voltage sensing relay K6 are mounted on control box relay assembly A4, a subassembly of control cubicle A3.

b. Inspect. To inspect relays K1 and K6, proceed as follows:

(1) Turn three quick-release studs located at top of control cubicle to release position.

(2) Allow control cubicle panel to drop to open position.

(3) Inspect relays K1 and K6 on relay assembly A4 (mounted on rear of control cubicle) for bent or broken pins, signs of overheating, and signs of obvious damage.

(4) Close control cubicle panel and secure by turning three quick-release studs to lock position.

4-76. RESISTORS. Resistors are to be inspected for cracks, signs of overheating, or discoloration, and leads that may have cold solder joints.

4-77. PRINTED CIRCUIT BOARDS. Printed circuit boards are to be inspected for loosened foil, carbonized areas, cold solder joints, and signs of obvious damage.

4-78. CONVENIENCE RECEPTACLES ASSEMBLY A22.

a. General. The convenience receptacle assembly A22 contains a 125-volt, 15-ampere duplex receptacle which has a spring-loaded weatherproof cover. The receptacle is connected in parallel electrically, and is protected by a 15-ampere circuit breaker.

b. Removal. To remove the assembly (located below the control cubicle), disconnect plug P48 from the receptacle connector J48 in the rear of the assembly, then remove the six screws and lockwashers securing the assembly to the rear housing.

c. Disassembly. Refer to figure 4-42 to disassemble the convenience receptacle assembly. Pay particular attention to the following:

- (1) Remove six screw assemblies (1) and separate the cover (9) from the housing (24).
- (2) Tag and disconnect wires from circuit breaker (20) and the duplex receptacle (17).

WARNING

Dry cleaning solvent, P-D-680, Type II, is flammable and moderately toxic to the skin, eyes, and respiratory tract. Skin, eye, and respiratory protection is required.

d. Cleaning. Clean all components with a lint-free cloth moistened with cleaning solvent (P-D-680, Type II) and dry thoroughly.

e. Inspection. To inspect convenience receptacle, proceed as follows:

- (1) Inspect connectors for bent, broken, and missing pins. Check wires for continuity, and for shorts to case and surrounding pins.
- (2) Check terminal lugs and soldered connections for condition and security.
- (3) Check circuit breakers and receptacles for continuity.
- (4) Inspect sheet metal parts for dents, cracks, and distortion.

Legend for Figure 4-42

- |                      |                    |                          |
|----------------------|--------------------|--------------------------|
| 1. SCREW ASSEMBLY    | 9. COVER           | 17. DUPLEX RECEPTACLE    |
| 2. SCREW ASSEMBLY    | 10. SCREW ASSEMBLY | 18. NUT                  |
| 3. NUT ASSEMBLY      | 11. NUT ASSEMBLY   | 19. LOCKWASHER           |
| 4. CONNECTOR         | 12. COVER          | 20. CIRCUIT BREAKER      |
| 5. CABLE STRAP       | 13. SCREW          | 21. SCREW                |
| 6. TERMINAL LUG      | 14. GASKET         | 22. NUT                  |
| 7. WIRE              | 15. SCREW ASSEMBLY | 23. IDENTIFICATION PLATE |
| 8. INSULATING TUBING | 16. SCREW ASSEMBLY | 24. HOUSING              |

f. Repair. To repair convenience receptacle, proceed as follows:

- (1) Repair defective wiring (refer to FO-1).
- (2) Straighten dented or distorted sheet metal parts using proper tools.

g. Reassembly. Refer to figure 4-42 and reassemble convenience receptacle assembly. Pay particular attention to the following:

- (1) Connect wires in accordance with FO-1.
- (2) Install connector plug (4) with keyway up.

h. Installation. Install the convenience receptacle assembly in the rear housing and secure in position with six screws and lockwashers. Connect plug P48 to connector J48 in the rear of the assembly.

4-79. FUSEHOLDERS. If required, inspect fuseholder for cracks or signs of overheating.

4-80. FUSES. If required, inspect fuses for continuity using an ohmmeter set to RX1 scale. Replace as required.

4-81. CURRENT TRANSFORMERS. If required, inspect current transformers for signs of overheating, cracks, broken leads, or other signs of obvious damage.

4-82. WIRING HARNESS. If required, inspect wiring harness for continuity, shorts to ground or adjacent wires, frayed insulation, loose or broken terminals, and loose wires (refer to paragraph 4-32).



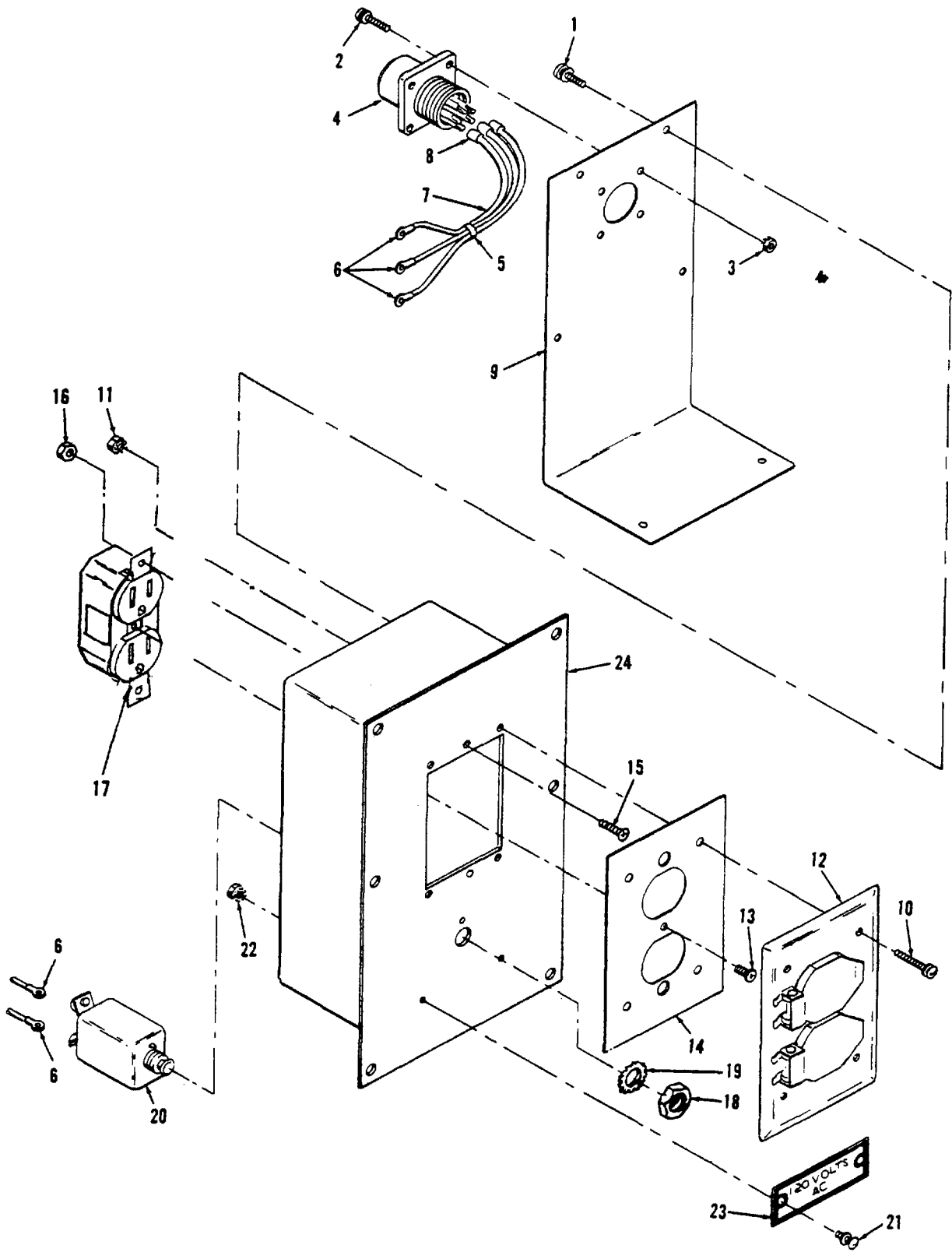

Figure 4-42. Convenience Receptacle Assembly, Exploded View

## Section XII. MAINTENANCE OF FUEL SYSTEM

4-83. GENERAL. The fuel system (see figure 1-4) consists of the following major components: a fuel tank assembly; a fuel transfer valve; two electric fuel transfer pumps; a primary fuel filter and strainer; a fuel solenoid valve; a day tank, a secondary fuel filter; a fuel injection pump; injection valves; and various lines, fittings, and valves. These components of the fuel system are described in the following paragraphs. The ether system, which functions in conjunction with the fuel system, is described in paragraph 4-91.

a. Fuel Tank Assembly. The fuel tank stores fuel for generator set operation and is located within the skid base assembly. The fuel level send unit (transmitter) senses the fuel level in the tank and transmits a signal to the fuel gage on the control cubicle, which indicates a reading corresponding to that of the fuel level transmitter. The drain valve located on the fuel tank permits draining of the tank and removal of water and sediment from the tank.

b. Fuel Transfer Valve. The fuel transfer valve, auxiliary fuel inlet fitting and cap, and fuel supply outlet fitting and cap are located adjacent to the fuel filler cap. The auxiliary fuel inlet fitting permits connection of an auxiliary fuel supply to the fuel transfer valve. The fuel supply outlet fitting permits connection to the fuel tank so it may be utilized as an auxiliary fuel supply. The fuel transfer valve is a mechanically operated three-way valve. It permits selection of fuel from the generator set fuel tank or an auxiliary fuel supply.

c. Electric Fuel Transfer Pumps. The fuel transfer pumps B2 and B3 are 24 V dc pumps that provide a flow of 25 gph (95 liters per hour). The pumps draw fuel from the fuel tank or auxiliary fuel supply and pump the fuel to the day tank at approximately 7 psig (48 kPa) when the fuel solenoid valve is open. If the fuel solenoid valve is closed, the pumps bypass fuel internally. The pumps are connected electrically in parallel; the fuel connections are in series.

d. Primary Fuel Filter and Strainer. The primary fuel filter and strainer assembly is the initial filtration device in the fuel system. The strainer element is reuseable after cleaning, but the filter element must be replaced.

e. Fuel Solenoid Valve L2. Fuel solenoid valve L2 is an electrically operated shutoff valve that opens and closes to maintain a predetermined fuel level in the day tank. When the day tank fuel level is decreased, the day tank float switch completes a circuit which directs electrical power to the fuel solenoid valve L2 causing it to open. When the valve opens, fuel flows to the day tank until a predetermined level is reached. Electrical power is then removed from the solenoid valve L2 by the float switch, closing the valve.

f. Day Tank. The day tank has a fuel capacity to permit engine operation for a minimum of 5 minutes. It provides a settling point for contaminants, to prevent their entry into the engine, and supplies fuel to the engine fuel pump. The tank contains a dual type float switch. The upper float operates in conjunction with the fuel solenoid valve L2 to maintain a predetermined

fuel level in the tank. The lower float initiates an engine shutdown sequence in the event that the fuel level in the tank will permit operation of the generator set, at rated load, for only 1 minute.

g. Secondary Fuel Filter. The secondary fuel filter is mounted on the right side of the engine. The secondary fuel filter is the final filtration device in the fuel system. It removes contaminate particles of 5 microns and larger from the fuel. The fuel relief valve limits maximum fuel pressure supplied to the fuel injection pump. When fuel pressure reaches 25 to 32 psig (172 to 220 kPa), the relief valve plunger opens routing fuel back to the day tank. The bleed valve which is located downstream from the secondary fuel filter permits air to be bled from the fuel system (refer to paragraph 4-87).

h. Fuel Injection Pump and Injector Valves (Injectors). The fuel injection pump is mounted on the engine assembly. The pump actually consists of six pumps (one for each cylinder) in a common housing with associated valves and tubing. Fuel, after passing through the secondary filter, flows into the injection pump housing manifold which distributes the fuel to each of the six injection pumps. The injection pump for each cylinder measures and delivers the fuel to its associated fuel injection valve for insertion into the precombustion chamber. The amount of fuel pumped per stroke is varied by turning the pump plunger in the barrel. This turning is accomplished by governor action through the fuel regulator rack and gear arrangement. Injection pump plungers and lifters are lifted by lobes on the fuel injection camshaft.

4-84. FUEL TRANSFER PUMPS B2 AND B3 (ELECTRIC). The following paragraphs provide test, service, and replacement procedures for the electric fuel transfer pumps B2 and B3 (figure 4-43).

a. Test.

(1) Connect fuel supply to IN port of electric fuel pump. Connect tube and suitable 10 psig gage (69 kPa) to OUT port.

(2) Apply 24 V dc to fuel pump and monitor gage. Allow air to bleed from pump, tube, and gage by "cracking" connecting nut until fuel is free of air bubbles. Pressure should be 7 psig +1/4 to -1/2 psig (48 kPa +1.7 to -3.4 kPa) and there shall be no external leakage at pump.

b. Service.

(1) Twist and remove cover and gasket from pump body (refer to figure 4-43).

(2) Carefully remove screen and magnet from body.

WARNING

Dry cleaning solvent, P-D-680, Type II, is flammable and moderately toxic to the skin, eyes, and respiratory tract. Skin, eye, and respiratory protection is required.

(3) Wash screen and magnet with cleaning solvent, P-D-680, Type II, and dry thoroughly.

(4) Inspect screen and gasket for tears. Replace defective screen or gasket.

(5) Position magnet, screen, and gasket in pump body and secure with cover.

c. Replace.

(1) Refer to figure 4-43 and disconnect two electrical connectors from engine harness.

(2) Disconnect elbows, hose assemblies, and connectors from fuel transfer pumps.

(3) Remove fuel transfer pumps by removing two screws, two washers, lockwasher, and two nuts which secure each pump to the mounting bracket.

(4) Install new pumps using two screws, two washers, lockwashers, and two nuts to secure each pump to the mounting bracket.

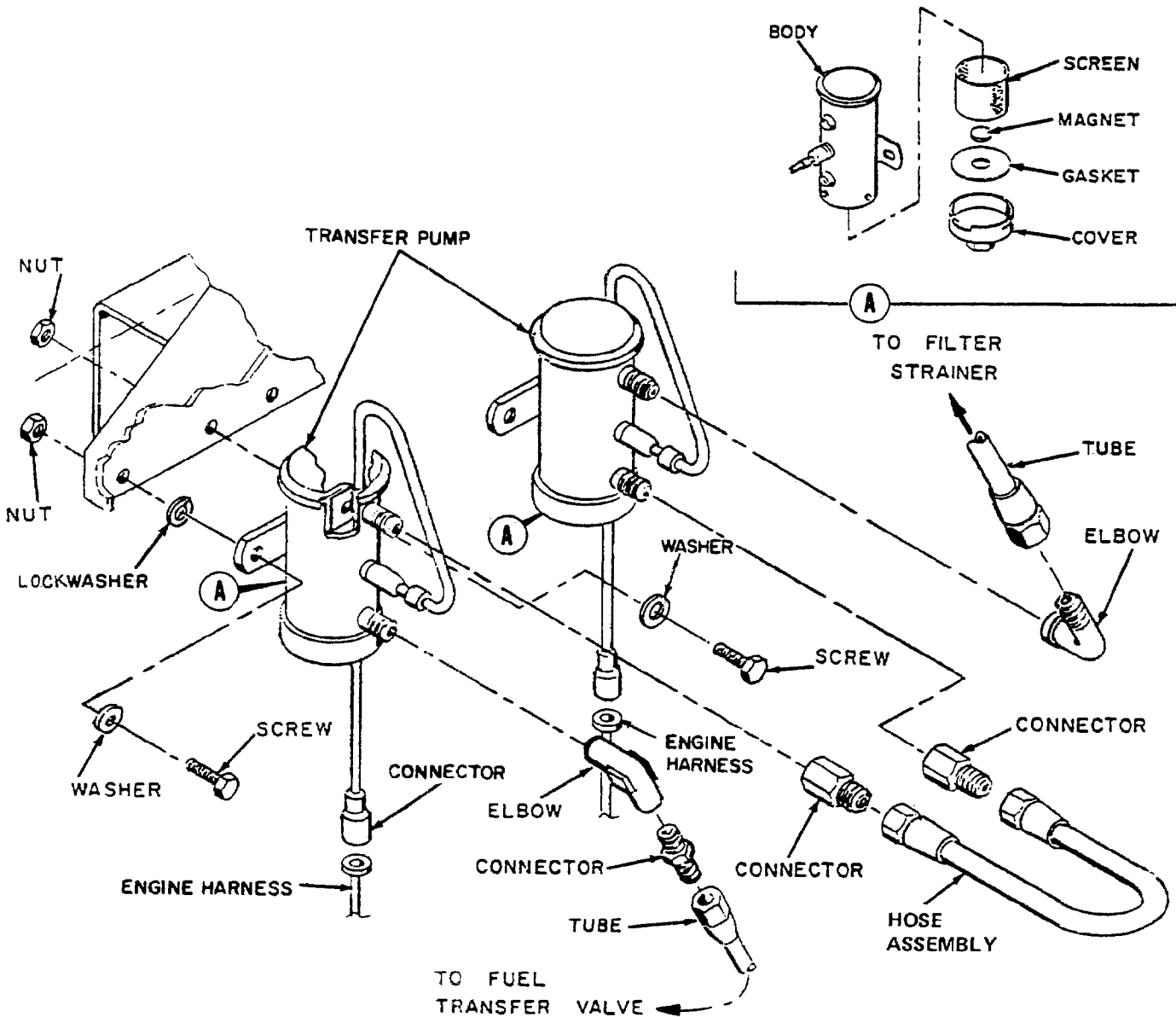

Figure 4-43. Electric Fuel Transfer Pumps, Exploded View

NOTE

Apply thread sealing compound conforming to MIL-S-45180, Type III, to pipe threads prior to installation.

(5) Connect elbows, hose assemblies, and connectors to fuel transfer pumps.

4-85. PRIMARY FUEL FILTER AND STRAINER. The following paragraphs provide service and replacement procedures for the primary fuel filter and strainer (figure 4-44).

a. Service.

(1) Open drain cocks (22 and 28, figure 4-44), and catch fuel in a nonflammable container.

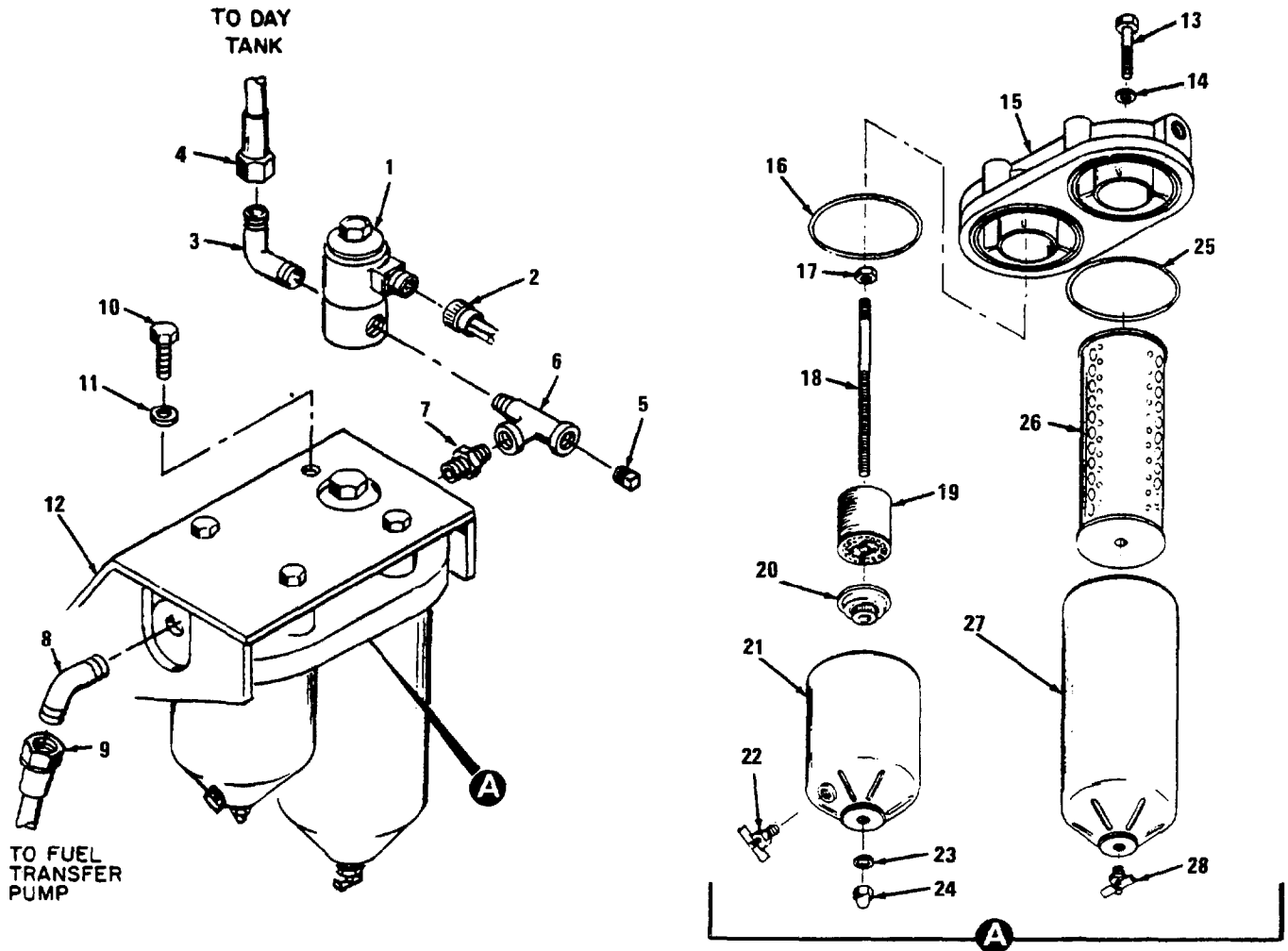

- |                  |             |                      |
|------------------|-------------|----------------------|
| 1. FUEL SOLENOID | 10. SCREW   | 19. STRAINER ELEMENT |
| 2. CONNECTOR     | 11. WASHER  | 20. RETAINER         |
| 3. ELBOW         | 12. BRACKET | 21. STRAINER BOWL    |
| 4. HOSE          | 13. BOLT    | 22. DRAIN COCK       |
| 5. PLUG          | 14. WASHER  | 23. GASKET           |
| 6. TEE           | 15. HEAD    | 24. NUT              |
| 7. NIPPLE        | 16. GASKET  | 25. GASKET           |
| 8. ELBOW         | 17. NUT     | 26. FILTER ELEMENT   |
| 9. HOSE          | 18. STUD    | 27. FILTER BOWL ASSY |
|                  |             | 28. DRAIN COCK       |

Figure 4-44. Primary Fuel Filter and Strainer Assembly and Fuel Solenoid Valve, Exploded View

(2) Hold strainer bowl and remove nut (24) and gasket (23). Remove bowl (21) and gasket (16) from head. Remove retainer (20) and strainer element (19) from stud (18).

(3) Hold filter bowl (27) and remove bolt (13) and washer (14). Remove filter bowl assembly (27) and gasket (25) from head, and filter element (26) from bowl.

WARNING

Dry cleaning solvent, P-D-680, Type II, is flammable and moderately toxic to the skin, eyes, and respiratory tract. Skin, eye, and respiratory protection is required.

(4) Wash bowls (21 and 27) and head (15) with cleaning solvent, P-D-680, Type II, and dry thoroughly.

(5) Wash strainer element (19) with clean fuel. Inspect element for damage.

(6) Replace gaskets (16, 23, and 25), filter element (26), and defective parts.

(7) Apply a thin coat of fuel to gaskets (16 and 25). Close drain cocks (22 and 28) and position gaskets on head.

(8) Install strainer element (19) and retainer (20) on stud (18). Position strainer bowl (21) on head (15) and secure with gasket (23) and nut (24).

(9) Position new filter element (26) filter bowl (27) and assembled bowl to head (15). Secure bowl to head with bolt (13) and washer (14).

b. Replace. Refer to figure 4-44.

(1) Open drain cocks (22 and 28) and catch fuel in a nonflammable container.

(2) Remove electrical connector (2) from fuel solenoid (1).

(3) Remove hose assemblies from filter and strainer assembly.

(4) Remove strainer bowl (21).

(5) Remove fuel filter, strainer, and bracket assembly from the engine by removing four nuts and washers mounting bracket to engine.

(6) Remove elbow and nipple from filter and strainer head.

(7) Remove four screws (10) and washers (11) securing filter and strainer assembly to mounting bracket (12).

(8) Install filter and strainer assembly on mounting bracket (12) and secure with four screws (10) and washers (11).

(9) Install elbow and nipple on filter and strainer head.

(10) Install fuel filter, strainer, and bracket assembly on engine and secure with four nuts and washers.

(11) Install strainer bowl (21).

(12) Install hose assemblies on filter and strainer assembly.

(13) Install electrical connector (2) on fuel solenoid (1)

(14) Ensure that the drain cocks (22 and 28) are tightened and prime the fuel system prior to starting the engine.

NOTE

Apply thread sealing compound conforming to MIL-S-45180, Type III to pipe threads prior to installation.

4-86. SECONDARY FUEL FILTER. The following paragraphs provide service and replacement procedures for the secondary fuel filter (figure 4-45).

a. Service.

(1) Open drain cock (2, figure 4-45) and catch fuel in a nonflammable container.

(2) Hold body (3) and remove bolt (4) and washer (5).

(3) Remove body (3), gasket (6), and element (7) from head (8). Discard gasket and element.

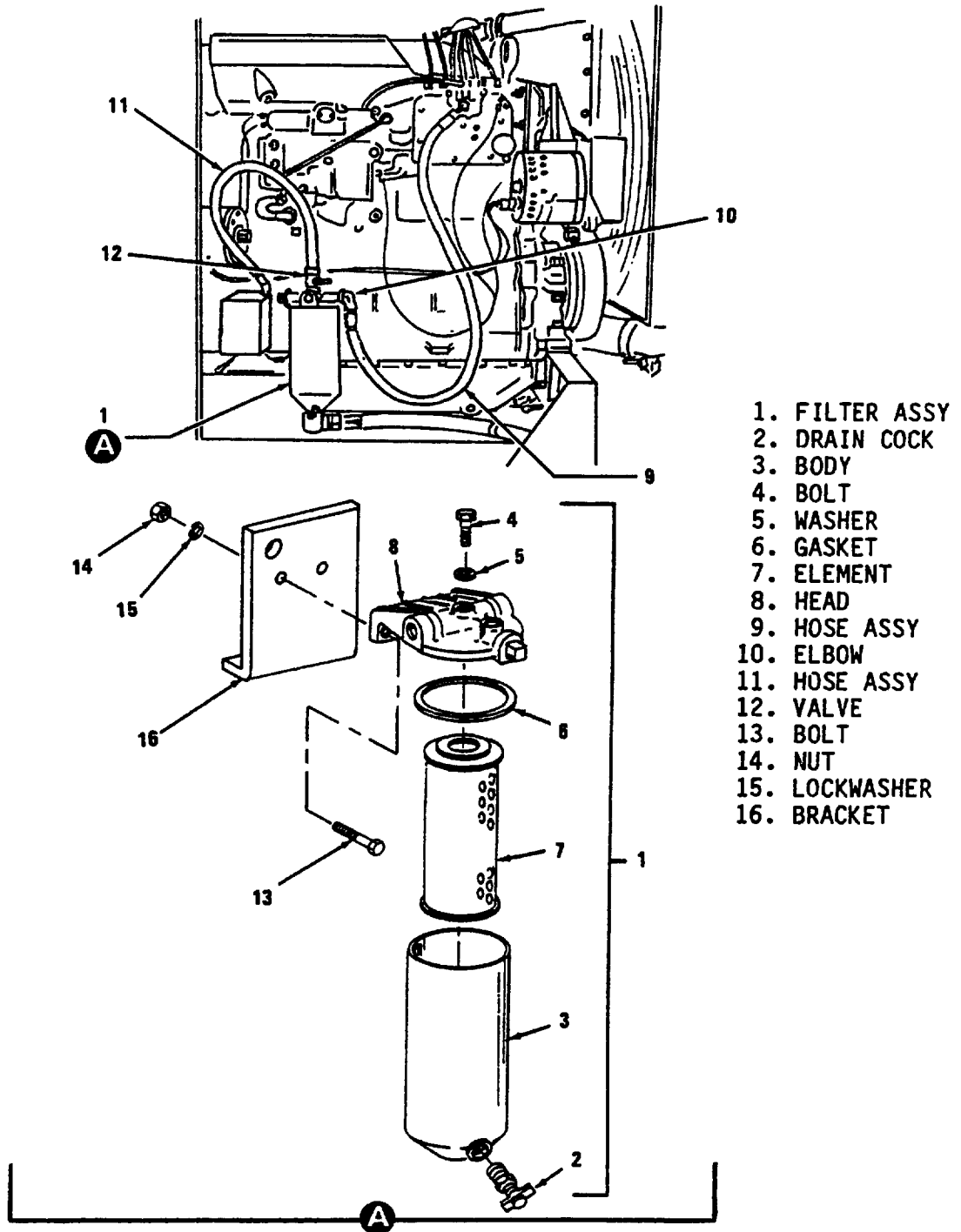

- 1. FILTER ASSY
- 2. DRAIN COCK
- 3. BODY
- 4. BOLT
- 5. WASHER
- 6. GASKET
- 7. ELEMENT
- 8. HEAD
- 9. HOSE ASSY
- 10. ELBOW
- 11. HOSE ASSY
- 12. VALVE
- 13. BOLT
- 14. NUT
- 15. LOCKWASHER
- 16. BRACKET

F9100674

Figure 4-45. Secondary Fuel Filter, Service and Replacement

**WARNING**

Dry cleaning solvent, P-D-680, Type II, is flammable and moderately toxic to the skin, eyes, and respiratory tract. Skin, eye, and respiratory protection is required.

(4) Wash body (3) in cleaning solvent, P-D-680, Type II, and dry thoroughly.

(5) Soak new element (7) in clean fuel to remove entrapped air. Apply a thin coat of fuel to gasket (6).

(6) Close drain cock (2). Position element (7) in body (3). Fill body with clean fuel. Position gasket (6) on head (8), then secure body and element with bolt (4) and washer (5).

a. Replacement.

(1) Open drain cock (2, figure 4-45) and catch fuel in a nonflammable container.

(2) Disconnect hose assembly (9), then remove elbow (10).

(3) Disconnect hose assembly (11), then remove valve (12).

(4) Remove two bolts (13), two nuts (14), and two lockwashers (15) to remove filter assembly (1) from bracket (16).

(5) Soak element (7) in clean fuel and fill body (3) with fuel.

(6) Coat gasket (6) with fuel, then assemble filter assembly (1).

(7) Install filter assembly (1) to bracket (16) using two bolts (13), two lockwashers (15), and two nuts (14).

**NOTE**

Clean threaded fittings prior to reinstallation and apply thread sealing compound conforming to MIL-S-45180, Type III.

(8) Install elbow (10), valve (12), and hose assemblies (9 and 11).

(9) Bleed fuel system in accordance with paragraph 4-87.

4-87. FUEL SYSTEM BLEEDING.

a. General. The fuel system should be bled after maintenance has been performed on components of the fuel system located after the day tank or whenever air is trapped in the fuel system.

b. Bleeding Procedure. Refer to figure 4-2 and bleed fuel system as follows:

(1) Place nonflammable container under fuel drain tube, then open fuel bleed valve.

c. General. After maintenance or inspection of the Fuel Injection Pump has been performed, the (hand) priming pump should be used to prime the injection pump to bleed air from the system.

d. Priming Procedure. Refer to figure 4-2 and prime the injection pump as follows:

(1) Place non-flammable container under fuel drain tube, then OPEN fuel bleed valve. Be sure to open the bleed valve, so pressure is release from the system and to prevent damage to the fuel system.

(2) Operate priming pump by hand, with rapid strokes.

(3) Observe fuel coming out of drain tube. When air-free fuel is flowing from drain tube, close bleed valve.

(4) Remove container from under drain tube.

**CAUTION**

Do not crank engine in excess of 15 seconds at a time. Allow starter to cool a minimum of 3 minutes between crankings.

(5) Start engine (refer to figure 2-5).

(6) Observe fuel coming out of drain tube. When air-free fuel is flowing from drain tube, close bleed valve.

(7) Remove container from under drain tube.

4-88. FUEL SOLENOID VALVE L2. The following paragraphs provide inspection, test, service, and replacement instructions for fuel solenoid valve L2 (figure 4-44).

a. Inspect. Check fuel solenoid for leaks and security of electrical connector.

b. Test. Test solenoid valve using an ohmmeter set on the RX1 scale. Check for continuity. If continuity is not indicated, the valve is defective and should be replaced.



WARNING

Dry cleaning solvent, P-D-680, Type II, is flammable and moderately toxic to the skin, eyes, and respiratory tract. Skin, eye, and respiratory protection is required.

c. Service. Clean valve with cleaning solvent, P-D-680, Type II, and dry thoroughly.

NOTE

Fuel filter, strainer, and bracket assembly must be removed to replace fuel solenoid valve (1, figure 4-44). Refer to paragraph 4-85b.

d. Replace.

(1) Disconnect hose (4, figure 4-44) from fuel solenoid valve (1) and install a plug.



(2) Remove elbow (3) and connector (2) from fuel solenoid valve.

(3) Unscrew fuel solenoid valve (1) from tee (6).

**NOTE**

Apply thread sealing compound conforming to MIL-S-45180, Type III, to pipe threads prior to installation.

(4) Replace fuel solenoid valve (1).

(5) Install elbow (3) and connector (2). Install tee (6).

(6) Remove plug from hose (4), then connect hose to elbow (3).

4-89. FUEL LEVEL SWITCHES FL1 AND FL2. The following paragraphs provide inspection, test, service, and replacement instructions for either of fuel level switches FL1 or FL2 (figure 4-46).

a. Inspect.

(1) Remove electrical connector (1, figure 4-46) from fuel level switch (10).

(2) Unscrew fuel level switch (10) from day tank (9).

(3) Check float switch to make sure there is no fuel in the floats. Check for worn or damaged threads.

(4) Install fuel level switch (10), then connect electrical connector (1).

**NOTE**

Apply thread sealing compound conforming to MIL-S-45180, Type III to pipe threads prior to installation.

b. Test.

**NOTE**

A test cable may be locally manufactured using connector plug NSN: 7510-00-282-8201, four alligator clips, NSN 5935-00-813-4714, and four, 36 inch long, #16 gage wires. Label the alligator clips A, B, C and D. The test cable may be used to bring the test points out, making the testing easier to accomplish.

(1) Remove electrical connector (1, figure 4-46) from fuel level switch (10), then unscrew switch from day tank (9).

(2) Support switch in vertical position (electrical connector on top). Connect an ohmmeter between connector pins C and D. Meter should indicate continuity. Raise lower float to upper limit. Meter should not indicate continuity.

(3) Connect ohmmeter between pins A and B. Meter should indicate continuity. Raise upper float to upper limit. Meter should not indicate continuity.

(4) Replace fuel level switch (10) (if defective) then connect electrical connector (1).

**NOTE**

Apply thread sealing compound conforming to MIL-S-45180, Type III, to pipe threads prior to installation.

c. Service.

(1) Remove fuel level switch (figure 4-46) as explained in step a, above.

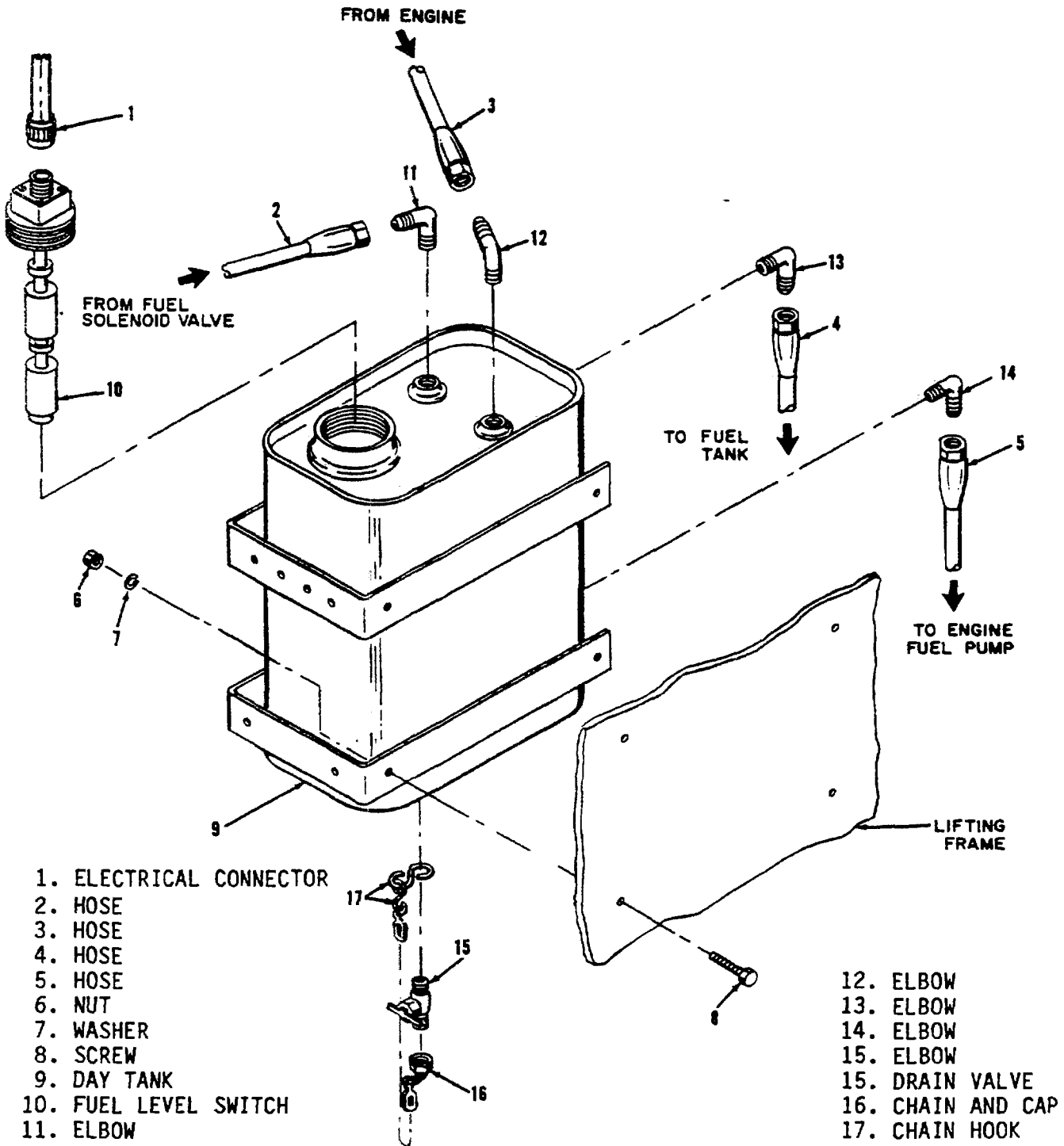

Figure 4-46. Fuel Level Switch and Day Tank, Exploded View

WARNING

Dry cleaning solvent, P-D-680, Type II, is flammable and moderately toxic to the skin, eyes, and respiratory tract. Skin, eye, and respiratory protection is required.

(2) Clean switch in cleaning solvent, P-D-680, Type II.

(3) Install switch as explained in step a, above.

d. Replace.

(1) Remove electrical connector (1, figure 4-46) from fuel level switch (10).

(2) Unscrew fuel level switch (10) from day tank (9).

(3) Install new fuel level switch (10) in day tank (9), then connect electrical connector (1).

NOTE

Apply thread sealing compound conforming to MIL-S-45180, Type III to pipe threads prior to installation.

4-90. FUEL LINES, VALVES, AND FITTINGS. Replace fuel lines, valves, and fittings as follows (refer to figures 4-43, 4-44, 4-45, and 4-46).

a. Remove lines, fittings, and valves by disconnecting them from their connection points.

b. Install suitable caps on connection points.

NOTE

Apply thread sealing compound conforming to MIL-S-45180, Type III, to pipe threads prior to installation.

c. Install new lines, valves, and fittings as required.

d. If lines, valves, or fittings located after (downstream) the day tank are replaced, bleed the fuel system in accordance with paragraph 4-87.

4-91. ETHER SYSTEM. The ether system aids engine starting during cold weather operation. The ether system consists of an ether cylinder, primer (solenoid valve), atomizer, tube, wiring, and engine primer switch. When the engine primer switch is positioned to ON, with the START-STOP-RUN switch in the start position, electrical power energizes the ether primer which momentarily off-seats the ether cylinder check valve. Off-seating of the check valve permits a metered amount of ether to flow through the atomizer. Ether passing through the atomizer is atomized and mixed with engine inlet air which increases the combustibility of the air/fuel mixture in the engine cylinders. The following paragraphs provide service and replacement procedures for the ether system (refer to figure 4-47).

a. Service. Service consists of replacement of the ether tank; proceed as follows:

(1) Open cylinder clamp (5, figure 4-47).

(2) Unscrew ether cylinder (6).

(3) Check cylinder condition by weighing cylinder on a scale. Full cylinder weighs 37 ounces (1 kg); an empty cylinder weighs 17 ounces (0.48 kg).

(4) Prior to installation of new cylinder, lubricate cylinder threads with one drop of OE 30 oil. Screw cylinder (6) into ether solenoid assembly until hand tight.

NOTE

If ether cylinder is being installed for the first time, remove protective cap from solenoid valve (15).

(5) Lock cylinder clamp (5) to secure cylinder (6).

b. Replace.

(1) Disconnect electrical connector (1, figure 4-47) and tube (2).

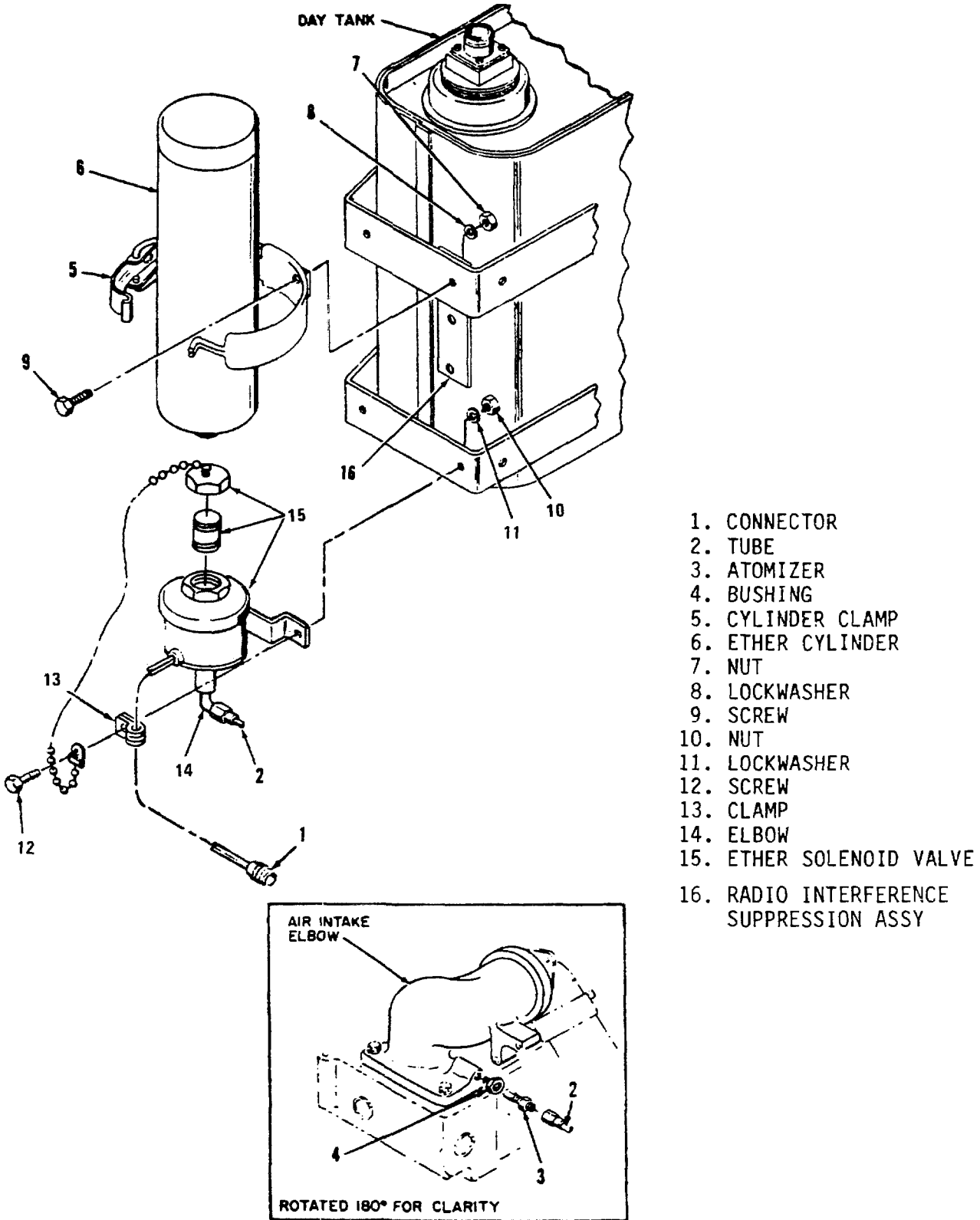

Figure 4-47. Ether System, Exploded View

(2) Remove atomizer (3) and bushing (4) from air intake elbow.

(3) Open cylinder (5) and unscrew ether cylinder (6).

#### CAUTION

Hold radio suppression diode assembly (see figure 4-9) in position when removing cylinder clamp (5).

(4) Remove cylinder clamp (5) by removing two screws (9), two lockwashers (8), and two nuts (7). Use screws (9), lockwashers, (8), and two nuts (7) to hold radio suppression diode in place.

(5) Remove ether solenoid valve (15) by removing two screws (12), two nuts (10), and two lockwashers (11).

(6) Remove elbow (14) from ether solenoid valve (15).

(7) Install new elbow (14) on solenoid valve (15).

(8) Slide clamp (13) over ether solenoid valve wiring, then secure ether solenoid valve (15) to day tank using two screws (12), two nuts (10), and two lockwashers (11).

(9) Hold radio interference suppression diode assembly and remove two screws (9), two nuts (7), and two lockwashers (8). Install clamp (5) using two screws (9), two lockwashers (8), and two nuts (7). Make sure screws pass through radio interference suppression diode assembly.

(10) Unscrew cap from ether solenoid valve (15).

(11) Prior to installation of new cylinder (6), lubricate cylinder threads with one drop of OE 30 oil. Tighten cylinder (6) hand tight.

(12) Lock clamp (5) to secure cylinder (6).

(13) Replace bushing (4), atomizer (3), and tube (2).

(14) Connect electrical connector (1).

4-92. FUEL INJECTION PUMP. Inspect the fuel injection pump refer as follows:

a. Inspect for security of attachment.

b. Start engine (refer to figure 2-5) and inspect leakage.

4-93. INJECTOR LINES AND VALVES. Fuel from the fuel injection pumps is sent through the fuel injection lines to the fuel injection valves (injectors).

a. Inspection of Fuel Injection Lines. Refer to figure 4-48 and inspect lines, for leaks, deformation and security of attachment. Cracked or missing paint may indicate a leak.

b. Replacement of Fuel Injection Lines. When fuel injection lines are removed from the engine put identification tags on the fuel lines as they are removed, so they can be put in the correct location when they are installed (see figure 4-48).

(1) Remove defective lines, as required, by loosening the nuts which secure the line to the fuel injection pump and fuel injection valve.

(2) Remove clamps and screws as required.

(3) Install new lines by first securing line to fuel injection pump and fuel injection valve. Tighten the fuel line nuts to 30 ±5 foot-pounds (40 ±7 Newton-meters).

c. Inspection and Replacement of Fuel Injection Valves.

(1) Remove fuel injection line(s) (1, figure 4-49) by loosening nut (2). Put a cap on the open fuel injection line(s).

(2) Remove nut (3).

(3) Remove the fuel injection valve and body (4) from precombustion chamber.

(4) Remove fuel injection valve (5) from body (6).

#### NOTE

Generator sets are not to be transported by air or forwarded to a repair facility with compressed ether cylinder attached.

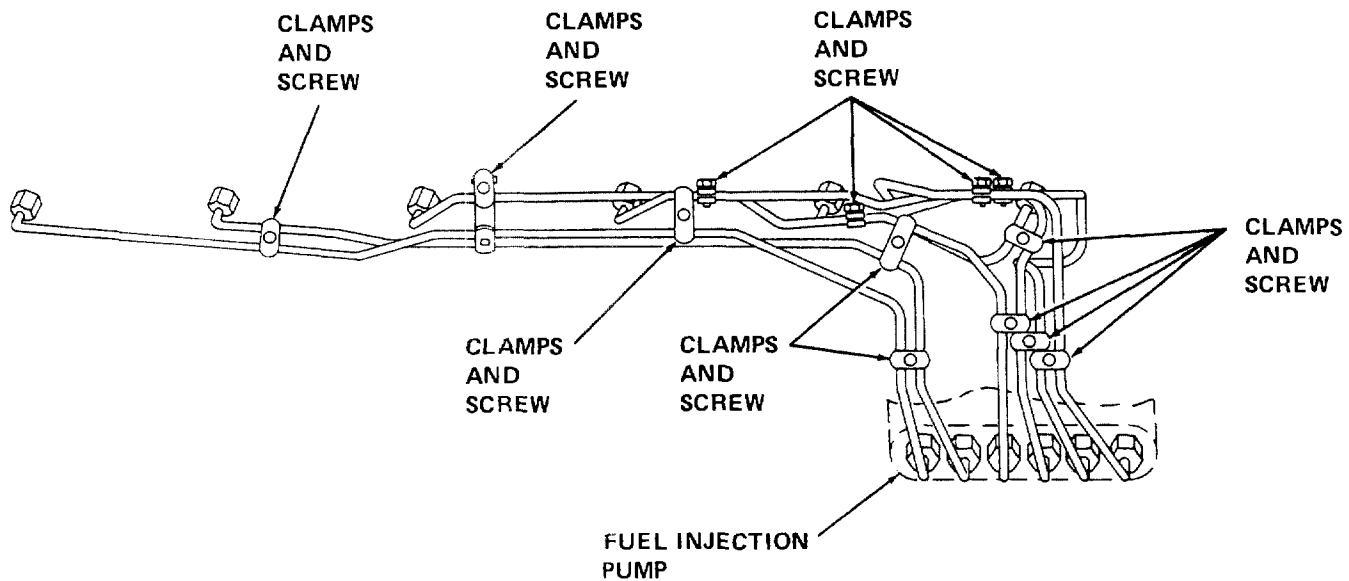

Figure 4-48. Fuel Injection Lines, Removal and Replacement

(5) Inspect the fuel injection valve for dirty or broken screen, excess carbon deposits on nozzle tip, and obvious signs of wear or damage. Inspect the body for worn or damaged threads and obvious signs of wear or damage. Replace defective valves and bodies.

(6) Assemble fuel injection valve (5) and body (6). Install fuel injection valve and body into precombustion chamber.

(7) Install and tighten nut (3) to a torque of 105 +/- 5 foot-pounds (142 +/- 7 Newton-meters).

(8) Remove cap from fuel injection line. Connect line and tighten nut (2) to a torque of 30 +/- 5 foot-pounds (40 +/- 7 Newton-meters).

4-94. FUEL FILLER AND CAP. To replace the fuel filler and cap, refer to figure 3-3, and proceed as follows:

a. Remove filler cap. Pull chain and remove tube from filler neck.

b. Unfasten chain hook and remove chain from tube.

c. Cover fuel tank opening.

WARNING

Dry cleaning solvent, P-D-680, Type II, is flammable and moderately toxic to the skin, eyes, and respiratory tract. Skin, eye, and respiratory protection is required.

d. Clean parts with cleaning solvent, P-D-680, Type II, and dry thoroughly.

e. Check filler cap vent valve for proper opening and closing.

f. Inspect strainer for holes, breaks, and tears.

g. Replace defective parts.

h. Connect chain to tube and fasten hook.

i. Insert tube in filler neck and install filler cap.

NOTE

Filler cap vent valve must be in open position during generator set operation.



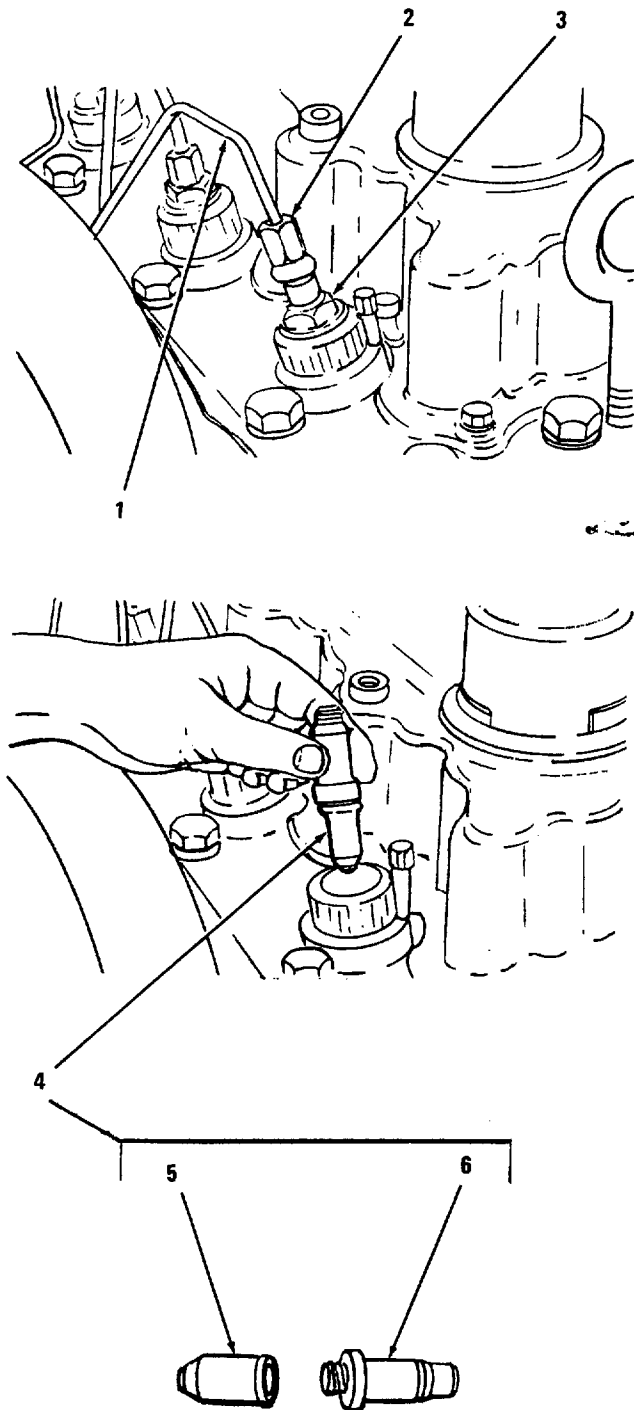

1. FUEL LINE
2. NUT
3. NUT
4. VALVE ASSY
5. VALVE ASSY, BOTTOM
6. VALVE ASSY, TOP

Figure 4-49. Fuel Injection Valves, Removal and Replacement

## Section XIII. MAINTENANCE OF EXHAUST AND BREATHER SYSTEM

4-95. GENERAL. The muffler and exhaust pipe are connected to the turbocharger exhaust elbow and provide a path for engine exhaust gases to exit the generator set. The muffler reduces the noise level of the engine exhaust. The discharge opening of the muffler is covered by a hinged cap to prevent water from entering the exhaust system when the generator is not operating. The crankcase breather tube is clamped to the engine breather assembly. The breather tube provides a path for engine crankcase fumes to exit the generator set. A rain shield is provided at the tube outlet to prevent rain from entering the tube.

4-96. INSPECTION. Inspect the exhaust and breather system as follows (see figure 4-50).

### WARNING

The muffler and exhaust pipe become extremely hot during generator set operation. Do not handle muffler or exhaust pipe when they are hot.

a. While generator set is not operating, check the following:

(1) Visually inspect the exhaust pipe (7), muffler (14), and breather tube (35) for damage, deformity, or rust.

(2) Inspect the exhaust cap (21) for damage, deformity, or rust. Check security of cotter pin (20), and free movement of exhaust cap.

(3) Check security of exhaust pipe and muffler clamps and other mounting hardware.

(4) Visually inspect breather hose (32) for signs of damage, deformity, or rot.

(5) Check security of rain shield (28), engine breather assembly (29), and hose clamps (30 and 33).

b. While generator set is operating, check for leakage of exhaust fumes.

4-97. REPLACEMENT OF MUFFLER, CLAMPS, EXHAUST PIPE, AND EXHAUST CAP.

### WARNING

The muffler and exhaust pipe become extremely hot during generator set operation. Do not handle muffler or exhaust pipe when they are hot.

a. Removal. See figure 4-50 and proceed as follows:

(1) Remove nuts (1), lockwashers (2), and screws (3) to separate exhaust pipe (7) from the turbocharger exhaust elbow.

(2) Remove nuts (4), lockwashers (5), and screws (6) to separate exhaust pipe (7) from muffler (14).

(3) Remove exhaust pipe (7), then remove and discard gaskets (8).

(4) Remove screws (9) and lockwashers (10), then remove plate (11) and gasket (12) from muffler (14).

(5) Hold the muffler (14) in position and remove clamps (13), then remove the muffler from the generator set.

(6) If the bracket (18) is damaged, remove nut (15), screw (16), and washers (17) to remove bracket (18).

(7) If the exhaust cap or support are damaged, remove retaining washer (19) and cotter pin (20) to

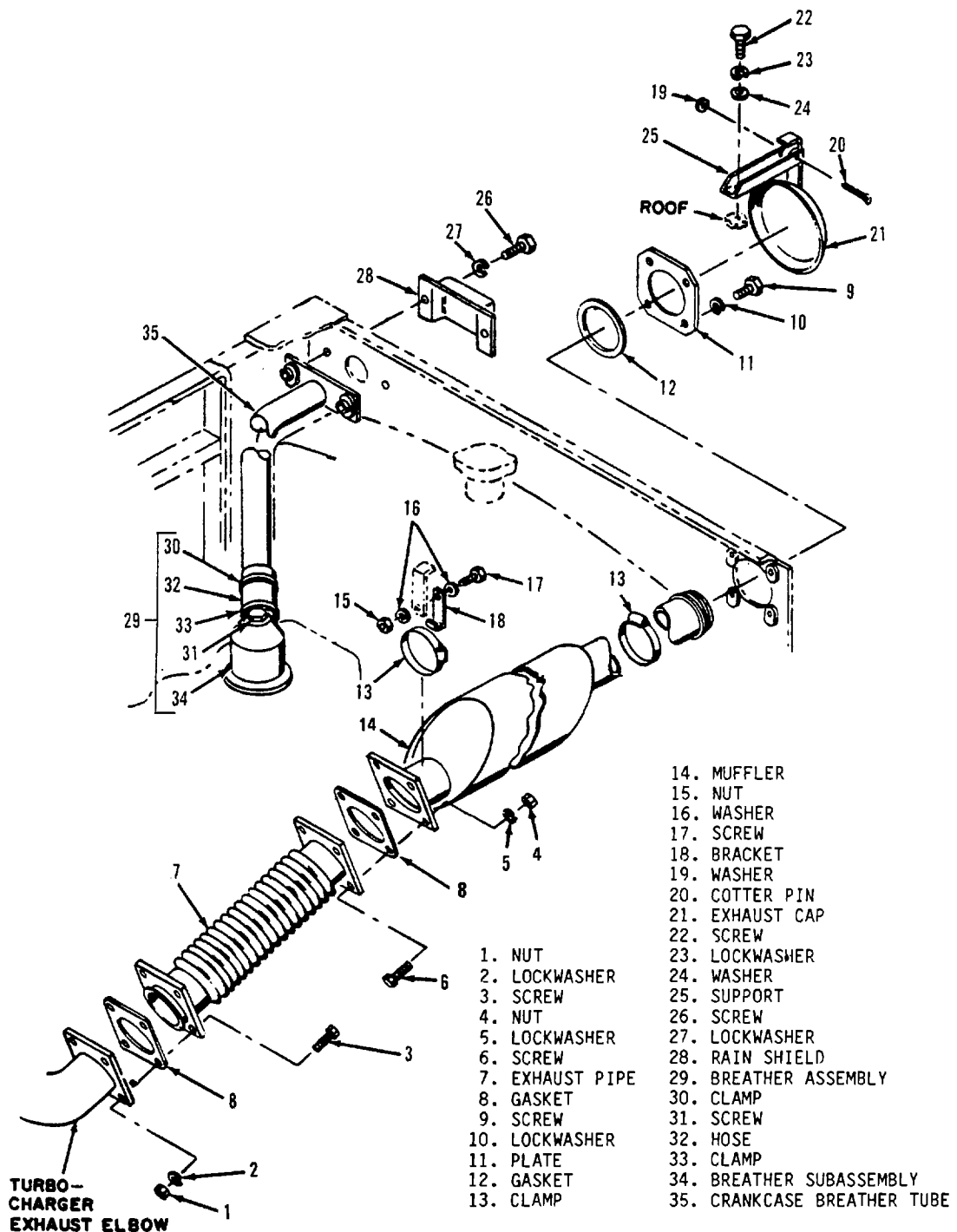

Figure 4-50. Exhaust and Breather System, Exploded View

remove exhaust cap (21). Remove screws (22), lockwashers (23), and washers (24) to remove support (25).

b. Installation.

NOTE

Apply antiseize compound to screw threads prior to installation.

(1) If bracket (18) was removed, install bracket using nut (15), washers (16), and screw (17).

(2) Position muffler and install clamps (13). Tighten clamps just enough to support muffler and still permit some movement of muffler.

(3) Position gaskets (8) on exhaust pipe (7) and install exhaust pipe. Secure with screws (3 and 6), washers (2 and 5), and nuts (1 and 4).

(4) Install gasket (12) and plate (11) using washers (10) and screws (9).

(5) Tighten clamps (13).

(6) If exhaust cap (21) was removed, mount cap (21) on support (25) with cotter pin (20) and washer (19). Attach support (25) to roof of housing using washers (24), lockwashers (23) and screws (22).

4-98. REPLACEMENT OF BREATHER TUBE AND HOSE.

WARNING

The breather tube and hose become extremely hot during generator set operation. Do not handle tube or hose while they are hot.

a. Removal. See figure 4-50 and proceed as follows:

(1) Remove screws (26) and washers (27) to remove rain shield (28).

(2) Loosen forward engine breather clamp (30). Loosen engine breather screw (31) to permit movement of breather assembly (29).

(3) Hold engine breather hose (32) stationary and twist breather tube (35) to separate tube from hose (32).

(4) Loosen rear engine breather clamp (33) to remove engine breather hose (32) from engine breather subassembly (34). Cover engine breather opening immediately.

b. Installation.

(1) Install engine breather hose (32) on engine breather subassembly (34) using clamp (33).

(2) Attach breather tube (35) to engine breather assembly using clamp (30).

(3) Secure breather tube (35) and rain shield (28) to housing using screws (26) and washers (27).

(4) Tighten engine breather screw (31) to secure engine breather assembly to engine. Tighten all clamps.

## Section XIV. MAINTENANCE OF COOLING SYSTEM

4-99. GENERAL. The cooling system provides a means of regulating engine temperature by controlling both the flow of coolant through the engine and radiator, and the flow of air around the radiator. The coolant absorbs heat from the engine, and transfers some of this heat to the air flowing around the radiator core. The system consists of a radiator and shutter assembly with thermostat, radiator hoses, a water pump, a coolant regulator, fan guard, and fan belts.

The radiator, shutter assembly, and fan guard are mounted to the front housing panel. The water pump and coolant regulator are mounted to the engine block. The fan belts are located on the engine block, stretched between the crankshaft pulley and the fan pulley.

a. The shutter assembly consists of movable vanes mounted in nylon bearings, a control assembly, and a control rod which actuates the vanes. The control assembly and control rod automatically open and close the shutter vanes to regulate the air flow as necessary to maintain the engine at normal operating temperature. When the engine coolant temperature reaches 158°F (69°C), the shutter thermostat power element begins to extend, causing the control rod to open the shutter vanes. The vanes must be fully open when the coolant temperature reaches 173°F (78°C). A return spring forces the shutter thermostat power element to contract when the coolant temperature decreases, causing the control rod to close the vanes. The shutter assembly

is equipped with a manual control handle to permit manual operation of the shutter vanes. The handle should be in full "up" position during normal operation.

b. The radiator consists of a core assembly, top and bottom tanks, upper and lower shrouds, the shroud plate, and the vent tube. As coolant passes through the radiator core, heat is transferred from the core to air forced through the radiator by the fan. The radiator expels 35 BTU's of heat per minute when the engine is operating at 1500 rpm, 34 BTU's at 1800 rpm, and 37 BTU's at 2000 rpm. The radiator operates at 4 to 7 psig (27.7 to 48.2 kPa), which is controlled by the radiator cap. The shrouds and shroud plate ensure that air drawn by the fan is forced through the radiator when exiting the generator set. The vent tube permits overflowing coolant to escape from the radiator.

c. The water pump is mounted on the left front side of the engine. It is driven by the camshaft gear and pumps engine coolant through the engine and radiator.

d. The coolant temperature regulator helps keep engine coolant temperature within operating range by governing the flow of engine coolant pumped through the engine by the water pump. At coolant temperatures below 174°F (78°C), the coolant is cycled through the pump and engine, but closed off from the radiator to retain engine heat. When the engine coolant temperature reaches 175°F (79°C), the regulator opens slightly to allow a small flow of heated coolant into the radiator. As the coolant temperature increases, the regulator increases the

AIR FORCE  
ARMY  
NAVY  
MARINE CORPS

T.O. 35C2-3-442-11  
TM5-6115-600-12  
NAVFAC P-8-628 12  
TM-07464B-12

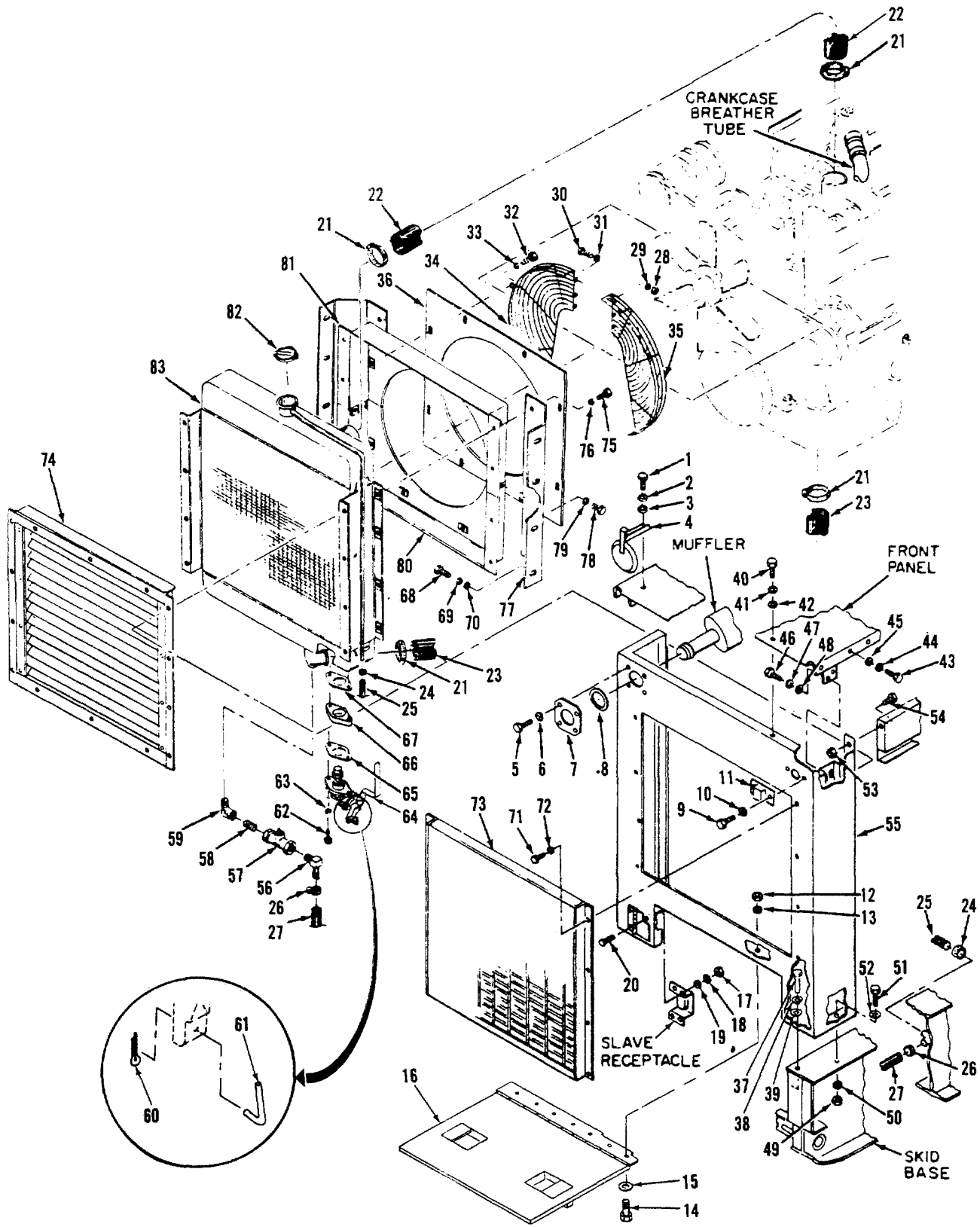

Figure 4-51. Radiator and Shutter Assembly

Legend for Figure 4-51

- |                         |                              |
|-------------------------|------------------------------|
| 1. SCREW                | 42. WASHER                   |
| 2. LOCKWASHER           | 43. SCREW                    |
| 3. WASHER               | 44. LOCKWASHER               |
| 4. RAIN CAP AND SUPPORT | 45. WASHER                   |
| 5. SCREW                | 46. SCREW                    |
| 6. LOCKWASHER           | 47. LOCKWASHER               |
| 7. PLATE                | 48. WASHER                   |
| 8. GASKET               | 49. NUTS                     |
| 9. SCREW                | 50. WASHER                   |
| 10. LOCKWASHER          | 51. SCREW                    |
| 11. RAINSHIELD          | 52. WASHER                   |
| 12. NUT                 | 53. NUT                      |
| 13. WASHER              | 54. SCREW                    |
| 14. SCREW               | 55. FRONT HOUSING PANEL      |
| 15. WASHER              | 56. ELBOW                    |
| 16. BATTERY ACCESS DOOR | 57. DRAIN COCK               |
| 17. NUT                 | 58. NIPPLE                   |
| 18. LOCKWASHER          | 59. ELBOW                    |
| 19. WASHER              | 60. COTTER PIN               |
| 20. SCREW               | 61. SHUTTER CONTROL ROD      |
| 21. CLAMP               | 62. SCREW                    |
| 22. UPPER RADIATOR HOSE | 63. WASHER                   |
| 23. LOWER RADIATOR HOSE | 64. SHUTTER CONTROL ASSEMBLY |
| 24. CLAMPS              | 65. GASKET                   |
| 25. OVERFLOW HOSE       | 66. SPACER PLATE             |
| 26. CLAMP               | 67. GASKET                   |
| 27. COOLANT DRAIN HOSE  | 68. SCREW                    |
| 28. NUT                 | 69. LOCKWASHER               |
| 29. WASHER              | 70. WASHER                   |
| 30. SCREW               | 71. SCREW                    |
| 31. WASHER              | 72. WASHER                   |
| 32. SHROUD PLATE SCREW  | 73. GRILLE                   |
| 33. WASHER              | 74. SHUTTER                  |
| 34. RIGHT FAN GUARD     | 75. SCREW                    |
| 35. LEFT FAN GUARD      | 76. WASHER                   |
| 36. SHROUD PLATE        | 77. ANGLE BRACKET            |
| 37. SCREW               | 78. SCREW                    |
| 38. LOCKWASHER          | 79. WASHER                   |
| 39. WASHER              | 80. LOWER RADIATOR SHROUD    |
| 40. SCREW               | 81. UPPER RADIATOR SHROUD    |
| 41. LOCKWASHER          | 82. RADIATOR CAP             |
|                         | 83. RADIATOR                 |

flow of coolant into the radiator. The regulator closes automatically as the engine cools down.

e. The fan guards are mounted directly to the radiator shroud, and prevent personnel from coming into contact with the fan.

f. The fan belts transmit rotary energy from the crankshaft pulley to the fan drive hub to drive the fan.

#### 4-100. RADIATOR SHUTTER ASSEMBLY.

a. Inspect. Inspect radiator shutter assembly (see figure 4-51) for damaged or defective parts, cracking, peeling paint, rust, or scale. Inspect shutter vanes (see figure 4-51) for evidence of binding, loose mounting, and damaged or defective bearings.

b. Test.

(1) While engine is cold, test shutter vane position by trying to insert card stock or match book cover between the vanes. If shutter is properly adjusted, card stock or match book cover will not fit between vanes. If match book cover can be inserted between vanes, the shutter must be adjusted.

(2) Test manual operation of shutter by operating the hand lever.

(3) Test operation of shutter assembly under power as follows:

(a) Start and operate engine (see figure 2-5) until normal operating temperature (approximately 180°F, 84°C) is reached.

#### CAUTION

Monitor coolant temperature gage during test. Remove restriction from air intake or check louvers if coolant temperature becomes excessive.

(b) Restrict cooling air flow by partially closing air

intake doors. Vary restriction and observe shutter. Shutter vanes should open and close to maintain engine at normal operating temperature. Shutter vanes full open position is approximately 70 degrees from vertical. Maximum cooling air flow is attained between 60 degrees and 70 degrees.

(c) Remove restriction from air intake. Operate engine for 5 minutes or until engine coolant temperature returns to normal operating range (approximately 185°F, 84°C).

c. Adjust. Refer to figure 4-52 and adjust shutter control assembly as follows:

#### NOTE

Coolant temperature must be below 150°F (65°C) during adjustment procedure.

(1) Loosen lever setscrews. Pull plunger to full out position. Cutout in shaft should be next to plunger.

(2) Bottom plunger in control assembly by pushing in on plunger (toward power element).

(3) Make sure shutter vanes are fully closed and tighten lever setscrews.

d. Replacement of Radiator, Grille, and Shutter Assembly.

(1) Removal. Refer to figure 4-51 and proceed as follows:

#### WARNING

Do not perform this procedure while engine is running or during engine cool down after operation. Ensure that engine is cold before starting this procedure.

#### WARNING

Disconnect a negative battery cable before performing any maintenance on the cooling system.



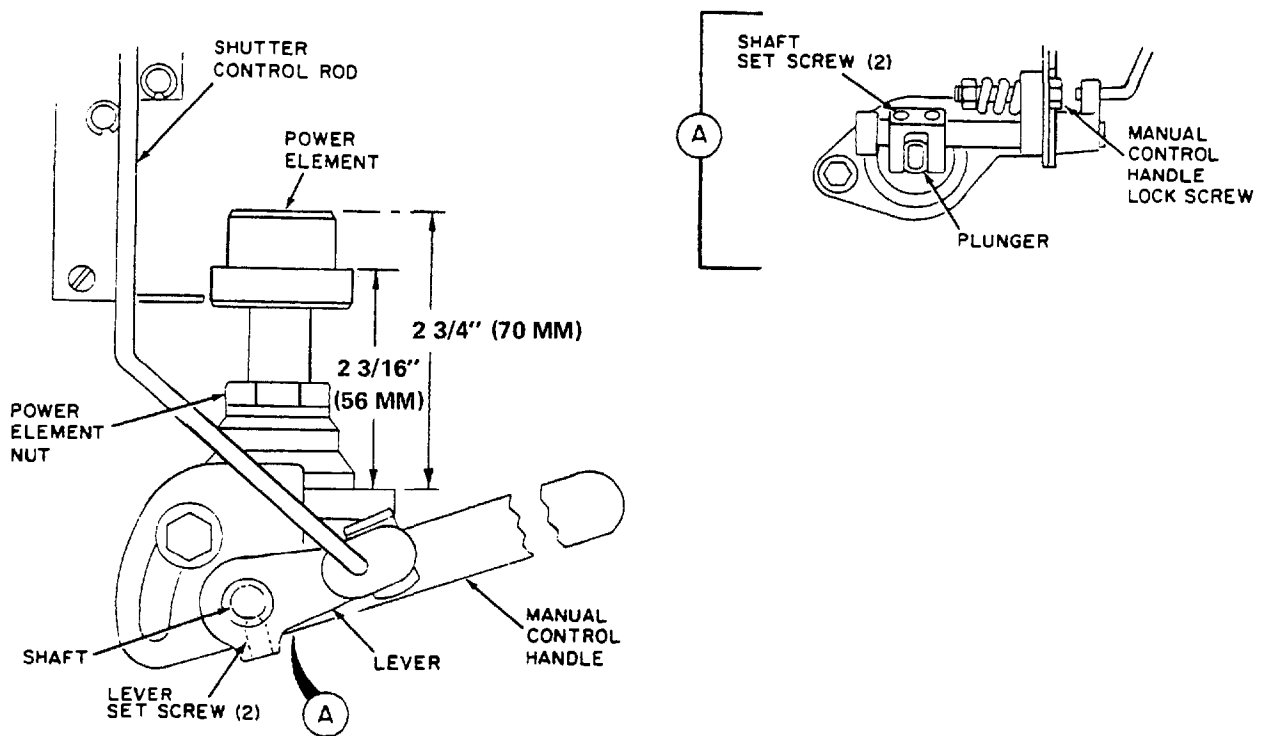

Figure 4-52. Shutter Control, Adjustment

(a) Drain engine coolant into a suitable container and preserve for reuse. Cover the coolant to prevent contamination.

(b) Remove one set of screws (1), lockwashers (2), and washer (3) to swing rain cap and support (4) out of the way.

(c) Remove screws (5), lockwashers (6), plate (7), and gasket (8) from front of housing.

(d) Remove screws (9), lockwashers (10), and rain shield (11) to separate the breather tube from the front housing.

(e) Remove nuts (12), washers (13), screws (14), and washers (15) to remove the battery access door (16).

(f) Remove nuts (17), lockwashers (18), and washers (19). Remove screw (20) to separate slave receptacle and bracket from the housing.

(g) Loosen clamps (21) securing the upper radiator hose (22).

(h) Remove the upper radiator hose (22) from the engine, then from the radiator.

(i) Loosen clamps (21) securing the lower radiator hose (23).

(j) Remove the lower radiator hose (23) from the water pump, then from the radiator.

(k) Remove clamps (24) and remove rubber overflow hose (25) extension.

(l) Remove clamps (26) and coolant drain hose (27).

(m) Remove nuts (28), washers (29), screws (30), and washers (31).

(n) Remove shroud plate screws (32) and washers (33) to remove right and left fan guards (34 and 35) and reposition shroud plate (36).

(o) Remove screws (37), lockwashers (38), and washers (39).

(p) Remove screws (40), lockwashers (41), and washers (42).

(q) Remove screws (43), lockwashers (44), and washers (45).

(r) Remove screws (46), lockwashers (47), and washers (48).

(s) Remove nuts (49), washers (50), screws (51), and washers (52).

(t) Remove nuts (53) and screws (54).

WARNING

At least two people and/or a lifting device will be needed to remove the front housing panel and radiator and shutter assembly.

(u) Remove the front housing panel (55) from the generator set with the radiator and shutter assembly and grille intact.

(v) Remove the coolant drain elbow (56), drain cock (57), nipple (58), and elbow (59).

(w) Remove the shutter control assembly cotter pin (60) to remove the shutter control rod (61) from the shutter assembly lever. Remove shutter control rod (61).

NOTE

It is not necessary to remove the lever or disassemble the shutter control assembly at this time.

(x) Remove screws (62), washers (63), shutter control assembly (64), gaskets (65 and 67), and spacer plate (66).

(y) Remove screws (68), lockwashers (69), and washers (70).

(z) Remove screws (71) and washers (72) to separate the grille (73) from the front housing panel (55). Remove the grille (73).

(aa) Separate front housing panel (55) from shutter (74). Remove the shutter (74).

(ab) Remove screws (75) and washers (76). Remove angle bracket (77).

(ac) Remove screws (78) and washers (79). Remove lower and upper radiator shrouds (80 and 81).

(ad) Remove radiator cap (82) from radiator (83).

(2) Installation.

(a) Secure cap (82) to radiator (83). Install upper and lower radiator shrouds (81 and 80) using screws (78) and washers (79).

(b) Use screws (75) and washers (76) to install angle bracket (77).

(c) Position shutter (74) and radiator (83) inside front housing panel (55). Mount the grille (73) using screws (71) and washers (72) to secure grille and to secure shutter (74) and radiator (83) to housing panel (55). Using shutter manual control handle, open and close shutter and check for binding. If binding is present, loosen screws and retighten evenly. Repeat until there is no binding.

(d) Install screws (68), lockwashers (69), and washers (70).

(e) Position gaskets (65 and 67) and spacer plate (66) on shutter control assembly (64). Install shutter control assembly (64) using screws (62) and washers (63).

(f) Insert shutter control rod (61) into shutter assembly lever. Secure control rod with cotter pin (60).

(g) Install elbow (59), nipple (58), drain cock (57), and the coolant drain elbow (56).

WARNING

At least two people and/or a lifting device will be needed to lift the front housing panel and radiator assembly into place.

(h) Position the front housing panel (55) on the generator

set. Secure the front housing panel (55) using screws (54) and nuts (53). Using shutter manual control handle, open and close shutter and check for binding. If binding is present, loosen screws and retighten evenly. Repeat until there is no binding.

(i) Install screws (51), washers (52 and 50) and nuts (49).

(j) Install screws (46), lockwashers (47), and washers (48).

(k) Install screws (43), lockwashers (44) and washers (45).

(l) Install screws (40), lockwashers (41), and washers (42).

(m) Install screws (37), lockwashers (38), and washers (39).

(n) Mount shroud plate (36) and right and left fan guards (34 and 35) using shroud plate screws (32) and washers (33).

(o) Join right and left fan guard halves using screws (30), washers (31 and 29), and nuts (28).

(p) Install coolant drain hose (27) using clamps (26).

(q) Install overflow hose (25) using clamps (24).

(r) Install lower radiator hose (23) and secure with clamps (21).

(s) Install upper radiator hose (22) and secure with clamps (21).

(t) Mount slave receptacle and bracket using screws (20), washers (19), lockwashers (18) and nuts (17).

(u) Install battery access door (16) using screws (14), washers (15 and 13), and nuts (12).

(v) Install breather tube and rain shield (11) using screws (9) and lockwashers (10).

(w) Position gasket (8) and plate (7) around muffler discharge tube and secure with screws (5) and lockwashers (6).

(x) Mount rain cap and support (4) on top of housing using screws (1), lockwashers (2), and washers (3).

(y) Lubricate control rod and linkage with lubricating oil, Military Specification MIL-L-2104.

(z) Check to ensure that coolant draincock (57) is closed, and refill radiator with coolant in accordance with paragraph 3-14c.

(aa) Adjust shutter and control assembly as directed in step e, below.

(ab) Reconnect battery cables.

#### e. Disassembly and Reassembly of Shutter Control Assembly.

(1) Disassemble shutter control assembly as follows:

(a) Remove shutter control assembly (64, figure 4-51) in accordance with step d, above.

(b) Remove nut (1, figure 4-53), lockwashers (2), and screw (3). Remove lever (4).

(c) Loosen yoke assembly setscrew (P/O 7), remove retainer (5), shaft assembly (6), and yoke assembly (7).

(d) Remove nut (8), friction spring (9), screw (10), and washer (11).

(e) Remove handle (12).

(f) Remove shutter thermostat power element (13), nut (14), and packing ring (15) from shutter thermostat power element housing (16).

(2) Assemble shutter control assembly as follows (see figure 4-53):

(a) Install packing ring (15), nut (14), and shutter thermostat power element (13) onto shutter thermostat power element housing (16). Adjust power element to a dimensional setting of 2-3/4 inches (70 mm) (see figure 4-52) by screwing element in or out. Tighten nut (14) after adjustment.

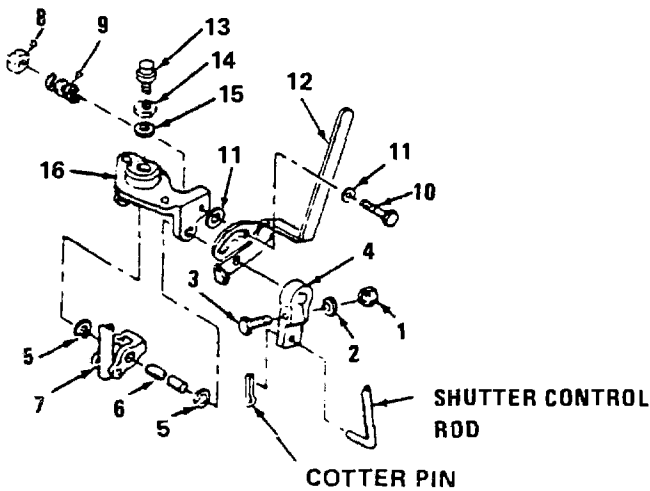

1. NUT
2. LOCKWASHER
3. SCREW
4. LEVER
5. RETAINER
6. SHAFT ASSEMBLY
7. YOKE ASSEMBLY
8. NUT
9. FRICTION SPRING
10. SCREW
11. WASHER
12. MANUAL CONTROL HANDLE
13. SHUTTER THERMOSTAT POWER ELEMENT
14. NUT
15. PACKING RING
16. SHUTTER THERMOSTAT POWER ELEMENT HOUSING

Figure 4-53. Shutter Control Assembly, Exploded View

**NOTE**

Shutter control assembly manual control handle lock screw should be loose enough to prevent position of manual control handle from interfering with automatic operation of shutter assembly.

(b) Slide shaft assembly (6) through shutter thermostat power element housing (16) and yoke assembly (7). Fasten retainers (5) to shaft assembly (6), and tighten yoke assembly setscrew (P/O 7).

(c) Install handle (12), washer (11), screw (10), friction spring (9), and nut (8).

(d) Install lever (4) with screw (3), lockwasher (2), and nut (1).

(e) Install shutter control assembly in accordance with step d, above.

f. Repair.

**WARNING**

Welding operations produce heat, highly toxic fumes, injurious radiation, metal slag and airborne particles. Welding goggles, the proper tinted lenses, apron or jacket, and welders boots are required.

- (1) Repair cracks in mounting brackets by welding.
- (2) Straighten distorted or bent parts.
- (3) Remove nicks and burrs using a file or stone.

**WARNING**

Paint is flammable and moderately toxic. Avoid skin and eye contact or breathing of vapors. Skin, eye, and respiratory protection is required.

- (4) Remove damaged paint using a scaper. Blend in edges,

prime, and repaint (olive drab, per MIL-T-704, Type A, semi-gloss, No. X24087) damaged areas.

(5) Repair damaged or defective hoses by replacement.

#### 4-101. SHUTTER THERMOSTAT.

##### a. Test.

(1) Remove shutter thermostat power element (13, figure 4-53) in accordance with paragraph 4-100e.

(2) Place power element and an accurate (test) thermometer in a container filled with water.

(3) Heat water and observe thermometer and shutter thermostat power element.

(4) Power element must start to extend at 158°F (69°C) and must be fully extended at 173°F (78°C) or the element is defective and must be replaced.

b. Replacement. Replace shutter thermostat power element (13, figure 4-53) in accordance with paragraph 4-100e.

#### 4-102. HOSES AND CLAMPS.

##### a. Replacement of Hoses.

(1) Drain engine coolant into a container and preserve for reuse. Cover coolant to prevent contamination.

(2) Loosen clamps (21, figure 4-51) and remove damaged or defective radiator hoses (22 and 23) in accordance to paragraph 4-100d(1)(g) through (j).

(3) Plug openings from which hoses were removed using tape or suitable plugs.

(4) Remove plugs just before positioning hoses (22 and 23). Secure radiator hoses with clamps (21).

##### b. Replacement of Clamps.

(1) Remove radiator hoses (22 and 23) in accordance with step a, above.

(2) Remove damaged or defective clamps (21).

(3) Install replacement clamps (21).

(4) Remove plugs and install hoses. Secure hoses with clamps (21).

#### 4-103. REPLACEMENT OF THE RADIATOR.

a. Removal. Remove damaged or defective radiator in accordance with paragraph 4-100d(1).

b. Installation. Install radiator in accordance with paragraph 4-100d(2).

#### 4-104. REPLACEMENT OF WATER PUMP.

a. Inspect. Inspect the water pump for leaks or signs of obvious damage. Check plug (10, figure 4-54) for security.

b. Removal.

##### WARNING

Ensure that engine is cold and that a negative battery cable is disconnected before starting this procedure.

(1) Drain engine coolant into a suitable container and preserve for reuse. Disconnect a negative battery cable.

(2) Disconnect coolant temperature sender wire (P/O 11).

(3) Loosen clamp (9, figure 4-54).

(4) Remove bolts (3 and 8) and remove elbow (4).

(5) Loosen clamp (1) and remove lower radiator hose (2) from water pump (6).

(6) Remove water pump (6) by removing bolts (5).

##### c. Installation.

(1) Install water pump (6) and secure with bolts (5).

(2) Install lower radiator hose (2) and secure with clamp (1).

(3) Install elbow (4) and bolts (3 and 8).

(4) Secure clamp (9).

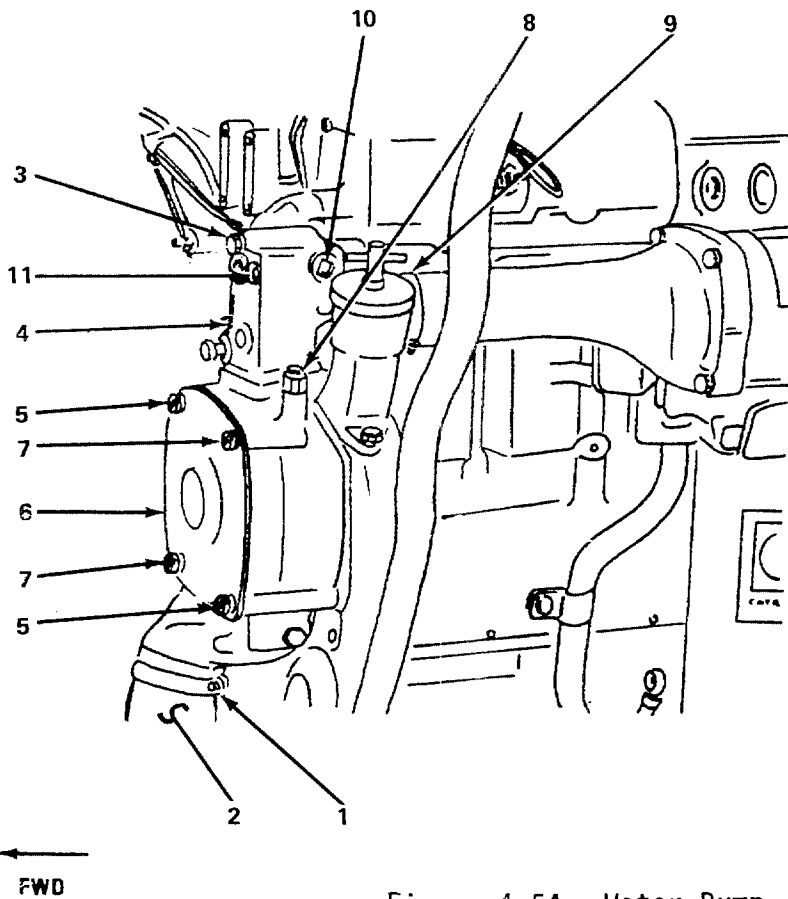

1. CLAMP
2. LOWER RADIATOR HOSE
3. BOLT
4. WATER ELBOW
5. BOLT
6. WATER PUMP
7. BOLT
8. BOLT
9. CLAMP
10. PLUG
11. COOLANT TEMPERATURE SENDER

Figure 4-54. Water Pump, Removal

(5) Connect coolant temperature sender wire (P/O 11).

(6) Close draincock and fill radiator with coolant.

#### 4-105. COOLANT THERMOSTAT.

a. Inspect. Visually inspect coolant thermostat housing for damage or deformity (see figure 4-55). Check for leakage around gasket or plug.

b. Test. (See figure 4-55.)

#### WARNING

Engine must be cold when removing thermostat for testing. Failure to observe this precaution may result in second- or third-degree burns.

(1) When engine is completely cold, remove radiator cap. Check to ensure that coolant is cold.

(2) Remove plug and allow any coolant trapped in upper radiator hose to escape.

(3) Remove bolts which secure housing to cylinder head.

(4) Separate housing from cylinder head. Remove and discard gasket.

(5) Remove coolant thermostat from cylinder head.

(6) Place coolant thermostat and a calibrated (test) thermometer in a container of cool water.

(7) Heat water and observe thermostat and thermometer. Thermostat must start to open at 175°F (79°C), and must be fully open at 195°F (90°C). If thermostat fails to open, it is defective and must be replaced.

(8) When thermostat is fully open, use a pair of pliers or

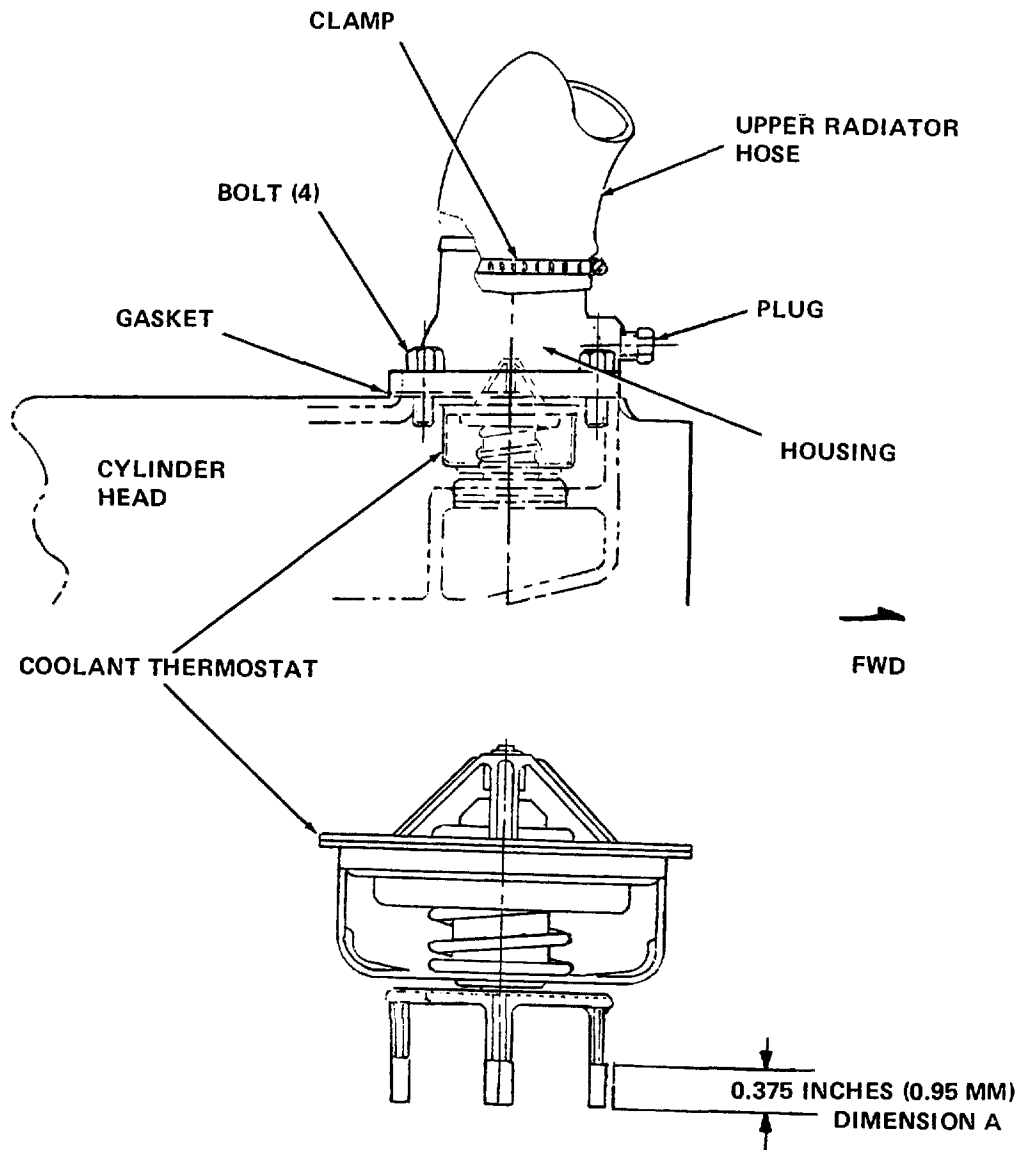

Figure 4-55. Coolant Thermostat, Replacement and Testing

similar tool to remove thermostat from water. Measure the movement of the thermostat as it cools. If the movement (dimension A) is less than 0.375 in (9.52 mm), the thermostat is defective and must be replaced.

(9) Install thermostat into cylinder head.

(10) Install new gasket.  
 (11) Position housing on cylinder head and secure with bolts (4).

(12) Install plug.  
 (13) Replace any lost coolant and install radiator cap.

c. Replace.

WARNING

Engine must be cold when replacing thermostat. Failure to observe this precaution may result in second- or third-degree burns.

- (1) Remove thermostat housing in accordance with step b, above.
- (2) If housing is being replaced, loosen clamp to separate housing from upper radiator hose.
- (3) Remove thermostat from cylinder head.
- (4) Install new thermostat into cylinder head.
- (5) Install new gasket.
- (6) Position housing on cylinder head and secure with bolts (4).
- (7) If housing was replaced, attach upper radiator hose and secure with clamp. Check security of plug. If housing was not replaced, install plug.
- (8) Replace any lost coolant and install radiator cap.

4-106. REPLACEMENT OF FAN GUARDS.

- a. Remove damaged or defective fan guards as follows (see figure 4-51):

WARNING

Ensure that engine is off and that a negative battery cable is disconnected before starting this procedure.

- (1) Remove nuts (28), washers (29 and 31), and screws (30) which hold right fan guard (34) and left fan guard (35) together.

CAUTION

Ensure that shroud plate does not shift and damage fan blades during fan guard replacement.

- (2) Remove shroud plate screws (32) and washers (33) from fan guard to be replaced. If both fan guards are to be replaced, ensure that shroud plate (36) does not shift and damage fan blades. Remove fan guard.

b. Install fan guards as follows:

- (1) Secure fan guard to shroud plate with screws (32) and washers (33).
- (2) Attach right (34) and left (35) fan guards with screws (30), washers (29 and 31), and nuts (28).

4-107. FAN BELTS.

a. Adjustment. Use fan bracket adjusting bolt (see figure 4-56) to adjust fan belt tension so that belt deflection (dimension A) is within the specified range when pressure is applied halfway between pulleys.

b. Replacement. Remove and replace fan belts as follows:

NOTE

Fan belts must be replaced as a set.

- (1) Remove fan guard in accordance with paragraph 4.106. (Optional)
- (2) Remove fan bolts and remove fan. (Optional)
- (3) Loosen fan bracket and remove fan belts.
- (4) Position new fan belts.
- (5) Use fan bracket and adjusting bolt to adjust fan belt tension (see step a, above).
- (6) Install fan and secure with fan bolts.
- (7) Install fan guard in accordance with paragraph 4-106, above.



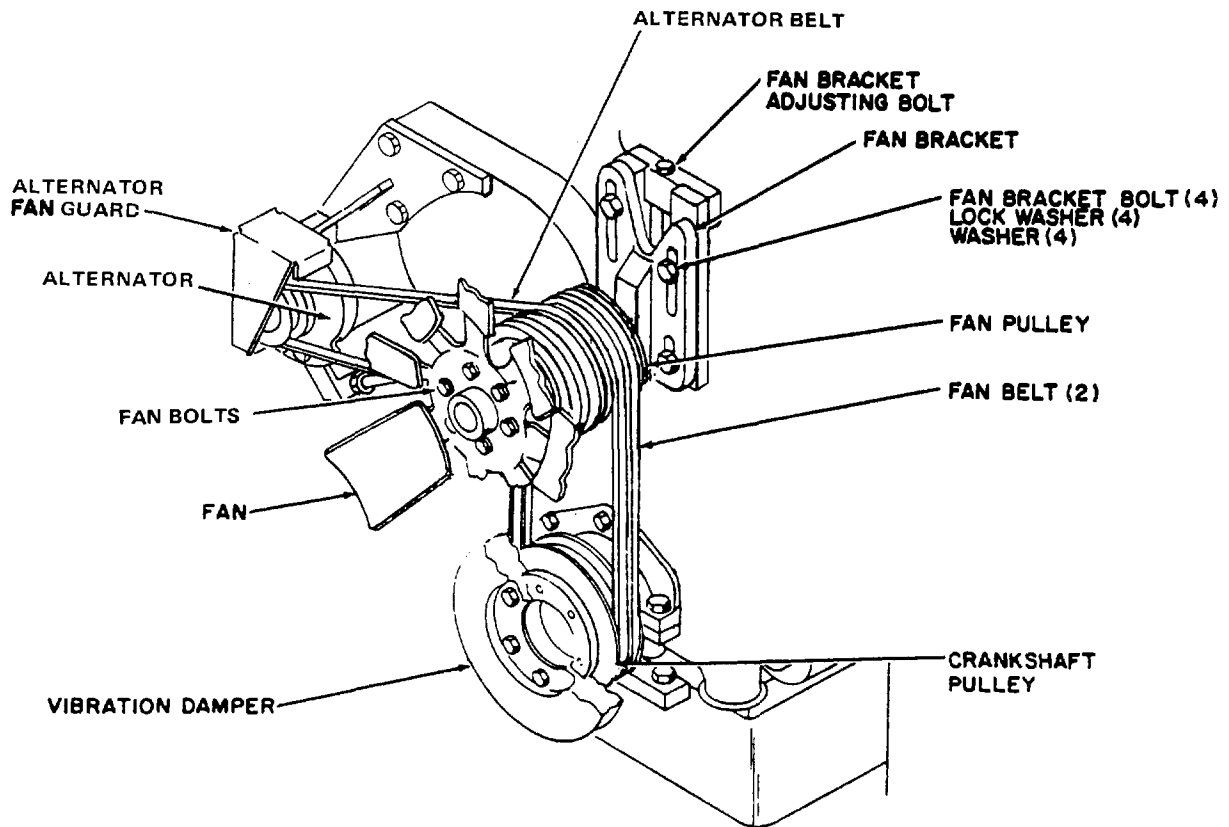

DIMENSION A	
NEW BELTS	USED BELTS
1/2 TO 3/4 IN. (12.7 TO 19.1 MM)	7/8 IN. (22.2 MM)

\*USED BELTS - OPERATED MORE THAN 30 MINUTES AT RATED SPEED

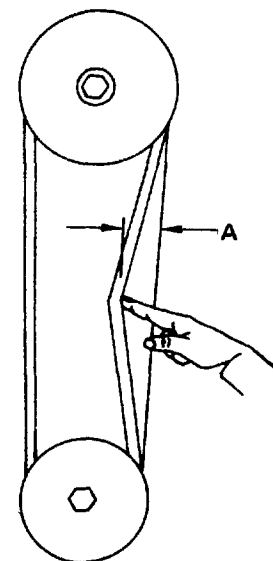

Figure 4-56. Fan Belts, Adjustment and Replacement

## Section XV. MAINTENANCE OF LIFTING AND SUPPORT SYSTEM

4-108. GENERAL. The lifting frame is bolted to the skid base and provides the means of lifting the generator set. Two clevis are located at the top of the lifting frame to permit attachment of a suitable lifting device. The lifting frame comprises the center support for the housing. The support system reinforces the sides of the rear housing panel, which includes the control panel and air intake louvers.

4-109. REPLACEMENT OF LIFTING FRAME. See figure 4-57 and replace the lifting frame as follows:

- a. Remove housing, as necessary, in accordance with instructions in Section VIII of this chapter.
- b. Remove fuel transfer valve, fuel inlet fitting, and fuel supply outlet fitting in accordance with paragraph 4-90.
- c. Remove ether tank (1) and solenoid valve in accordance with paragraph 4-91.
- d. Drain day tank. Remove four fuel hoses, four leads from radio suppression diodes (see figure 4-9), and remove connector to fuel level switch.
- e. Remove clamps (3) which secure fuel lines to the lifting frame (37).
- f. Loosen clamps (4) which secure hose (5) from filler neck to fuel tank. Remove hose (5) and plug tank opening.
- g. Remove fuel tank vent gang connections from filter neck (10). Remove screws (6), nuts (7), cap (8), filler tube (9), and filler neck (10).
- h. Remove and discard gasket (11).

- i. Remove nuts (12), washers (13), and screws (14) to remove manual speed control bracket (15).

- j. Connect an overhead lifting device with a 1/2-ton (907 t) capacity to clevis to prevent damage to equipment or injury to personnel. Remove nuts (16 and 20), washers (17 and 21), screws (18 and 22), and washers (19 and 23).

- k. Using an overhead lifting device with a 1/2-ton capacity (907 t), remove lifting frame (37) from skid base. Guide frame to prevent damage to components.

- l. Lower frame to ground and detach lifting device.

- m. Remove cotter pin (24), nuts (25), bolt (26), and clevis (27) from lifting frame (37).

- n. If necessary, remove fuel inlet plate (30) by removing nut (28) and screw (29). Remove fuel outlet plate (33) by removing nut (31) and screw (32). Remove fuel selector plate (36) by removing nut (34) and screw (35).

- o. If fuel inlet plate (30), fuel outlet plate (33), or fuel selector plate (36) were removed, install plate using associated screws and nuts.

- p. Install clevis (27) on lifting frame (37) using bolt (26), nuts (25), and cotter pin (24).

- q. Attach an overhead lifting device with a 1/2-ton (907 t) capacity to clevis and lift lifting frame (37) into position.

- r. Secure lifting frame (37) to skid base using screws (18 and 22), washers (17, 19, 21, and 23), and nuts (16 and 20). Remove lifting device from clevis (27).

- s. Install manual speed control bracket (15) using screws (14), washers (13), and nuts (12).

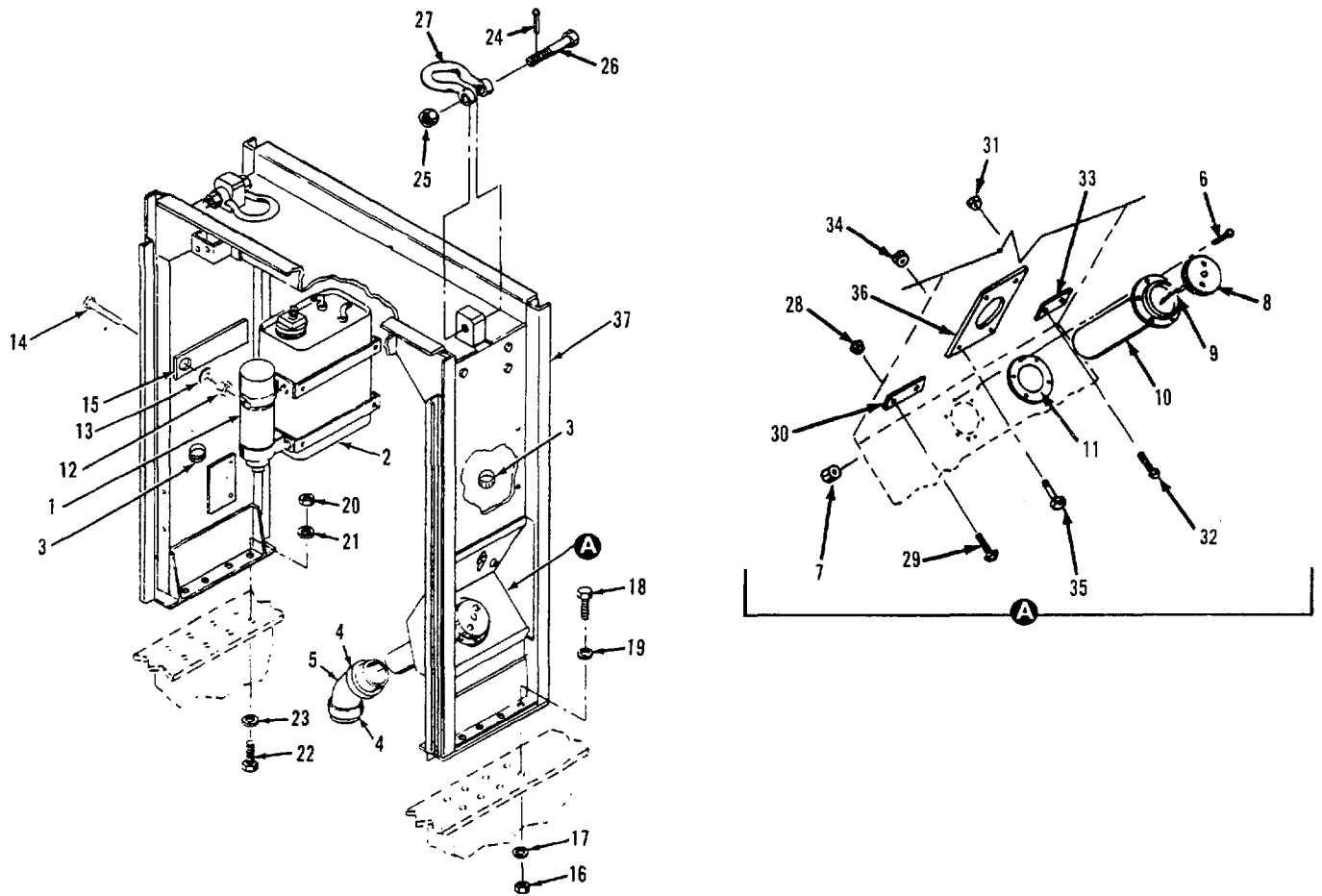

- 1. ETHER TANK
- 2. DAY TANK
- 3. CLAMP
- 4. CLAMP
- 5. HOSE
- 6. SCREW
- 7. NUT
- 8. CAP
- 9. FILLER TUBE
- 10. FILLER NECK
- 11. GASKET
- 12. NUT
- 13. WASHER
- 14. SCREW
- 15. MANUAL SPEED CONTROL BRACKET
- 16. NUT
- 17. WASHER
- 18. SCREW
- 19. WASHER

- 20. NUT
- 21. WASHER
- 22. SCREW
- 23. WASHER
- 24. COTTER PIN
- 25. NUT
- 26. BOLT
- 27. CLEVIS
- 28. NUT
- 29. SCREW
- 30. FUEL INLET PLATE
- 31. NUT
- 32. SCREW
- 33. FUEL OUTLET PLATE
- 34. NUT
- 35. SCREW
- 36. FUEL SELECTOR PLATE
- 37. LIFTING FRAME

Figure 4-57. Replacement of Lifting Frame

- t. Install new gasket (11).
- u. Install filler neck (10), filler tube (9), and cap (8), and secure with screws (6) and nuts (7). Install fuel tank vent gang connections on filler neck (10).
- v. Install hose (5) between filler neck and fuel tank. Secure hose (5) with clamps (4).
- w. Reconnect connector to fuel level switch, reconnect four leads to radio suppression diodes (see figure 4-9), and reconnect four fuel lines.
- x. Install ether tank (1) and solenoid valve in accordance with paragraph 4-91.
- y. Install fuel transfer valve, fuel inlet fitting, and fuel supply outlet fitting in accordance with paragraph 4-90.
- z. Secure fuel lines to lifting frame using clamps (3).
- aa. Install housing in accordance with instructions in Section VIII of this Chapter.

#### 4-110. REPLACEMENT OF CONTROL PANEL SUPPORTS.

- a. Remove rear housing cover (1, figure 4-58) in accordance with paragraph 4-22.
- b. Remove access doors (2, 3, and 4) in accordance with paragraph 4-21.
- c. Remove control box assembly (5) in accordance with paragraph 4-43.
- d. Remove DC circuit breaker (6) in accordance with paragraph 4-37.
- e. Remove the fault indicator assembly (7) in accordance with paragraph 4-42.
- f. Remove the manual speed control (8) in accordance with paragraph 4-59.
- g. Remove the convenience receptacle assembly (9) in accordance with paragraph 4-78.
- h. Remove the air intake louvers (10) in accordance with paragraph 4-26.
- i. Tag and disconnect wires to plate and sleeve assembly (13). Remove screw (11) and lockwasher (12) to remove plate assembly (13).

- j. Remove bolts (14) and lockwashers (15) and remove filler panels (39).
- k. Remove screws (16 and 19), lockwashers (17 and 20), and washers (18 and 21) which secure control panel housing (22) to the control panel supports (30 and 38).
- l. Remove right rear upper housing side (26) by removing screws (23), washers (24), and nuts (25).
- m. Steady right rear control panel support (30), and remove screw (27), lockwasher (28), and washer (29). Remove right rear support (30).
- n. Remove left rear upper housing side (34) by removing screws (31), washers (32), and nuts (33).
- o. Steady left rear control panel support (38), and remove screw (35), lockwasher (36), and washer (37). Remove left rear control panel support (38).
- p. Install left rear control panel support (38) using screws (35), lockwashers (36), and washers (37).
- q. Install left rear upper housing side (34) using screws (31), washers (32), and nuts (33).
- r. Install right rear control panel support (30) using screws (27), lockwashers (28), and washers (29).
- s. Install right rear upper housing side (26) using screw (23), washers (24), and nuts (25).
- t. Install control panel housing (22) and secure to control panel supports (30 and 38) using screws (16 and 19), lockwashers (17 and 20), and washers (18 and 21).
- u. Install filler panels (39) and secure with bolts (14) and lockwashers (15).
- v. Mount the plate and sleeve assembly (13) onto the control panel housing (22) using screw (11) and lockwasher (12). Connect wires and remove tags.
- x. Install air intake louvers (10) in accordance with paragraph 4-26.
- y. Install the convenience receptacle assembly (9) in accordance with paragraph 4-78.

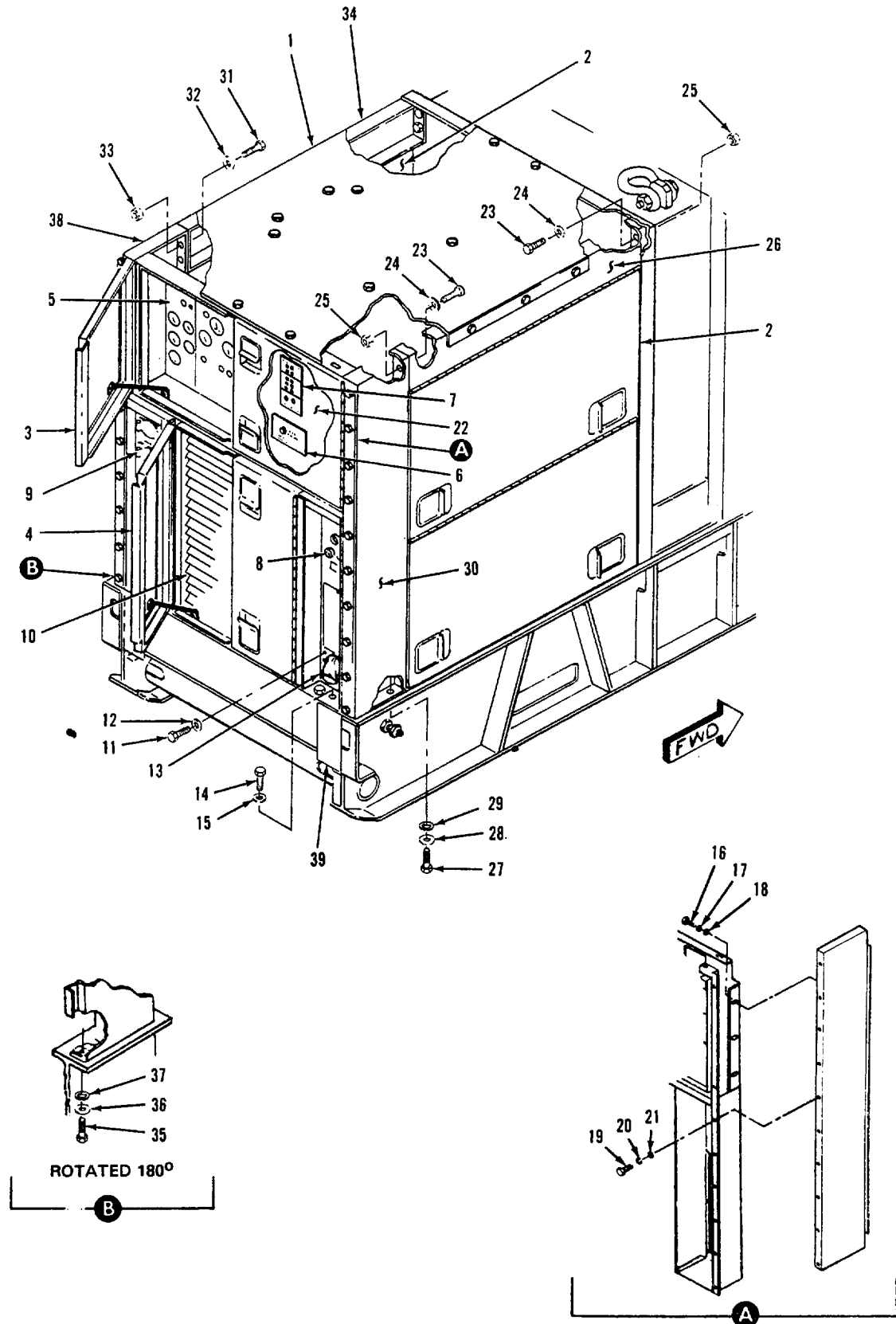

Figure 4-58. Replacement of Control Panel Supports

Legend for Figure 4-58.

- |                                |                                       |
|--------------------------------|---------------------------------------|
| 1. REAR HOUSING COVER          | 22. CONTROL PANEL HOUSING             |
| 2. ACCESS DOOR                 | 23. SCREW                             |
| 3. ACCESS DOOR                 | 24. WASHER                            |
| 4. ACCESS DOOR                 | 25. NUT                               |
| 5. CONTROL BOX ASSY            | 26. UPPER HOUSING SIDE, RIGHT REAR    |
| 6. DC CIRCUIT BREAKER          | 27. SCREW                             |
| 7. FAULT INDICATOR ASSY        | 28. LOCKWASHER                        |
| 8. MANUAL SPEED CONTROL        | 29. WASHER                            |
| 9. CONVENIENCE RECEPTACLE ASSY | 30. CONTROL PANEL SUPPORT, RIGHT REAR |
| 10. AIR INTAKE LOUVER          | 31. SCREW                             |
| 11. SCREW                      | 32. WASHER                            |
| 12. LOCKWASHER                 | 33. NUT                               |
| 13. PLATE AND SLEEVE ASSY      | 34. UPPER HOUSING SIDE, LEFT REAR     |
| 14. BOLT                       | 35. SCREW                             |
| 15. LOCKWASHER                 | 36. LOCKWASHER                        |
| 16. SCREW                      | 37. WASHER                            |
| 17. LOCKWASHER                 | 38. CONTROL PANEL SUPPORT, LEFT REAR  |
| 18. WASHER                     | 39. FILLER PANEL                      |
| 19. SCREW                      |                                       |
| 20. LOCKWASHER                 |                                       |
| 21. WASHER                     |                                       |

z. Install the manual speed control (8) in accordance with paragraph 4-59.

aa. Install the fault indicator assembly (7) in accordance with paragraph 4-42.

ab. Install the DC circuit breaker (6) in accordance with paragraph 4-37.

ac. Install the control box assembly (5) in accordance with paragraph 4-43.

ad. Install access doors (2, 3, and 4) in accordance with paragraph 4-21.

ae. Install rear housing cover (1) in accordance with paragraph 4-22.

## Section XVI. MAINTENANCE OF POWER GENERATION SYSTEM

4-111. GENERAL. The generator is a synchronous, brushless type with a rotating exciter. It is driven by the engine through a coupling. The generator can be connected to produce either 120/208 V ac or 240/416 V ac, three-phase, four wire, electrical current. The armature of the exciter, the field of the generator, and the rectifier assembly are mounted on a single rotating shaft. The field of the exciter and the armature of the generator are stationary. The output

of the generator armature is kept at a predetermined constant value by the generator set output. Residual magnetism of the generator pole pieces is relied upon to produce a small initial voltage which is increased as the generator comes up to speed. The exciter regulator flashes the field and this voltage is fed into the bridge rectifier assembly. The dc output of the rectifier assembly is coupled to the generator field (rotating on the shaft with the

exciter armature and rectifier assembly). The generator field induces an ac voltage in the stationary armature windings.

4-112. GENERATOR ASSEMBLY. Inspect for excessive heat during normal operation by checking for peeling paint, excessive noise, smoke, burnt areas, damaged air screens, and

abnormal odors (see figure 4-59). Refer to next higher level of maintenance if overheating exists.

4-113. BEARING. Inspect the generator bearing for signs of wear by checking for excessive or unusual noise, smoke, and abnormal odors. If any of these conditions exist, refer to next higher level of maintenance.

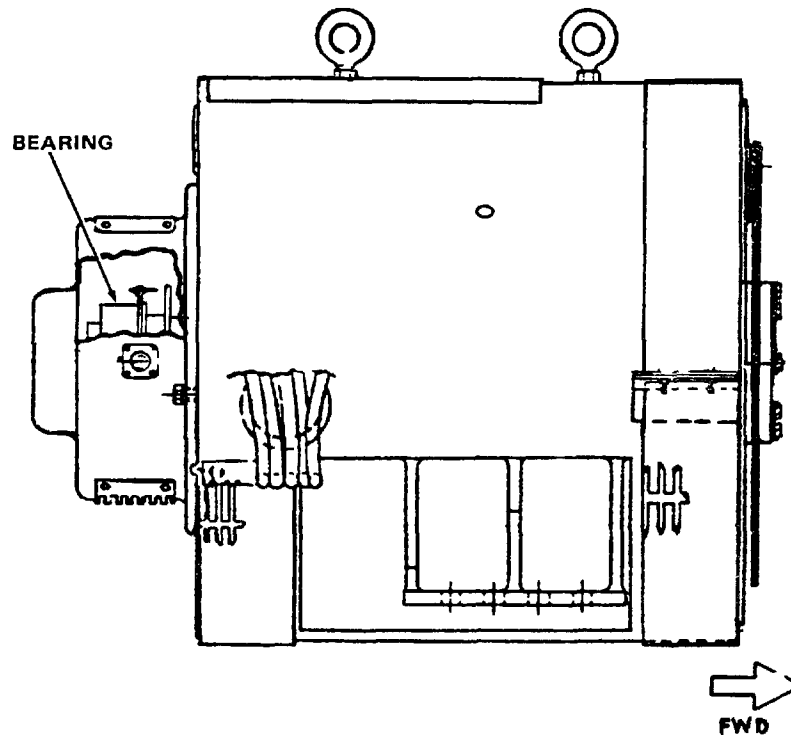

Figure 4-59. Generator Assembly, Inspection

## Section XVII. MAINTENANCE OF ENGINE

4-114. GENERAL. The engine provides mechanical (rotary) power to drive the generator. The engine is a six-cylinder, four-stroke cycle, liquid-cooled turbocharged diesel.

4-115. AIR FILTERS. Replace air filters as follows (see figure 4-60):

- a. Hold filter elements in position and loosen wing nuts.
- b. Pull down slightly on retainer bar and pivot bar toward control panel (clockwise).
- c. Remove filter elements carefully. Ensure gasket and filter material are not damaged.

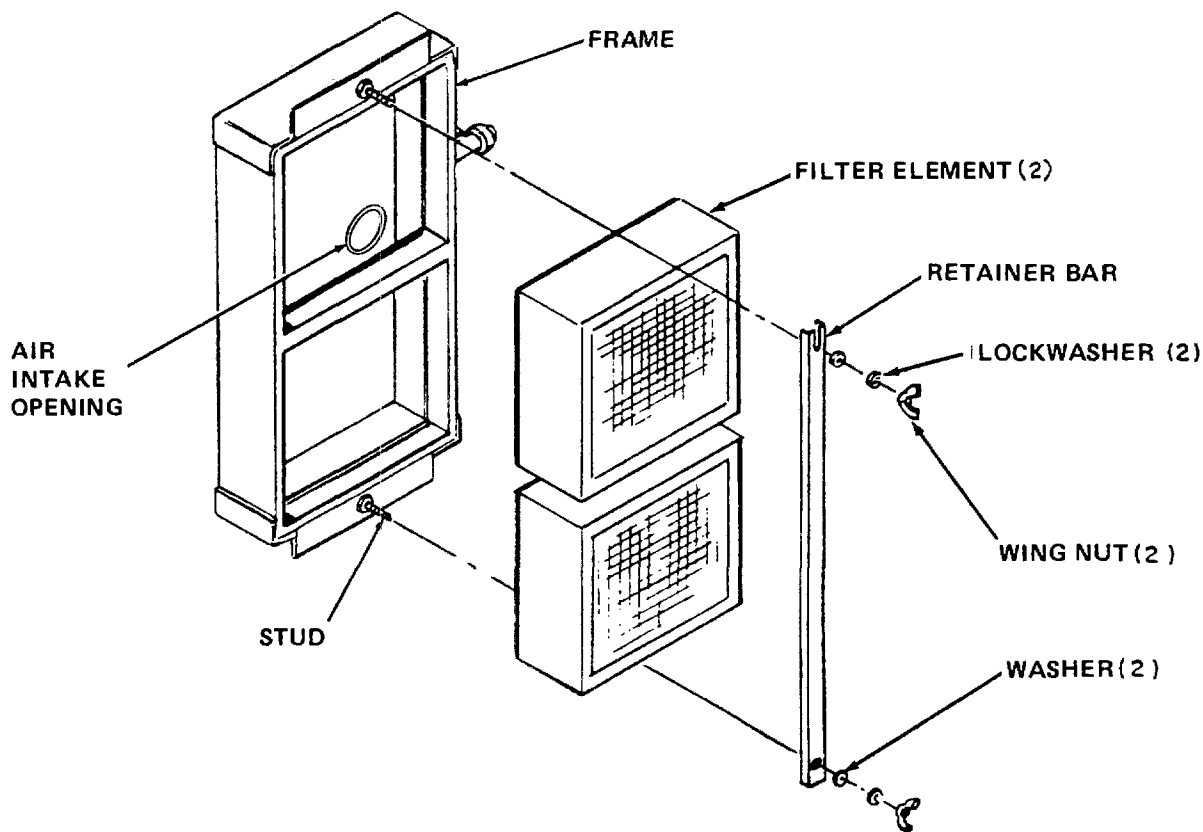

Figure 4-60. Air Filters

**CAUTION**

If replacement air filters are not installed immediately following filter removal, the air intake opening must be covered or plugged to prevent foreign matter from entering the engine.

d. Ensure that air cleaner frame is clean before installing filter elements.

e. Position filter elements in frame.

f. Pivot retainer bar into place and push bar up slightly onto stud.

g. Tighten both wing nuts.

4-116. TURBOCHARGER.

a. Inspection.

(1) Operate engine at approximate rated output and listen for unusual turbocharger noise. Do not mistake whine heard during rundown for one that indicates impeller shaft bearing failure during operation. Other unusual noises can result from improper clearance between turbine impeller and turbine housing. If such noises are heard, replace turbocharger. For repair of turbocharger, refer to higher level maintenance.



(2) Remove air cleaner assembly (refer to paragraph 4-115) to inspect turbocharger impeller vanes.

(a) Remove two screws (1, figure 4-61), washers (2 and 3), and nuts (4) to free air cleaner assembly (5) from bracket (6).

(b) Disconnect plug from pressure filter switch (17).

(c) Remove air cleaner assembly (5) from turbocharger (16).

(3) Inspect the turbocharger compressor wheel and housing for dirt (see figure 4-61). If the coating of dirt is light and even, cleaning the compressor wheel is not necessary. An uneven buildup of dirt will disturb the balance of rotating parts and lead to failure of the turbocharger. If the coating of dirt is uneven, excessive, or approaching the appearance of a layer which might flake off, cleaning is necessary. Refer to next higher level of maintenance.

(4) If turbocharger does not require replacement, install air cleaner assembly as follows:

(a) Insert air cleaner assembly (5) into air intake opening of turbocharger (16).

(b) Secure air cleaner assembly (5) to bracket (6) using screws (1), washers (2 and 3), and nuts (4).

b. Replacement.

(1) Remove air cleaner assembly in accordance with step a, above.

(2) Remove nuts (18), washers (19), and screws (20) to remove exhaust elbow (21).

(3) Remove two bolts (7), which secure turbocharger oil supply line. Plug oil line immediately.

(4) Remove two bolts (8) which secure turbocharger oil drain line. Plug oil line immediately.

(5) Loosen clamp (9) which secures turbocharger to exhaust elbow.

(6) Remove compressed air elbow (10).

(7) Remove nuts (11 and 14), washers (12 and 15), and bolts

(13) which secure turbocharger to exhaust manifold. Remove the turbocharger (16).

(8) Position new turbocharger (16) on exhaust manifold and secure with bolts (13), washers (12 and 15), and nuts (11 and 14). Torque nuts (11 and 14) to 40 +/-4 foot-pounds (54.2 +/-5 Newton-meters).

(9) Install air inlet elbow (10).

(10) Attach turbocharger (16) to exhaust elbow and secure by tightening clamp (9) to 10 foot-pounds (1.36 Newton-meters).

(11) Attach oil drain line and secure with bolts (8).

(12) Attach oil supply line and secure with bolts (7).

(13) Install exhaust elbow (21) and secure with nuts (18), washers (19), and screws (20).

(14) Install air cleaner assembly in accordance with step a, above.

4-117. GOVERNOR THROTTLE LINKAGE.

a. Adjustment. Adjust throttle linkage as follows (see figure 4-62):

(1) Remove bolt (1) and locknut (2) to disconnect rod (3) from fuel injection pump lever (4).

(2) Turn fuel injection pump lever (4) and governor control lever (8) fully counterclockwise.

(3) Adjust length of rod (3) to put bolt holes in rod (3) and lever (4) in alignment.

(4) Attach rod (3) to fuel injection pump lever (4) using bolt (1) and locknut (2).

b. Replacement. Replace throttle linkage as follows (see figure 4-62).

(1) Remove bolt (1) and locknut (2) to disconnect rod (3) from fuel injection pump lever (4).

(2) Remove bolt (5), washer (6), and locknut (7) to disconnect rod (3) from governor control lever (8). Remove rod (3).

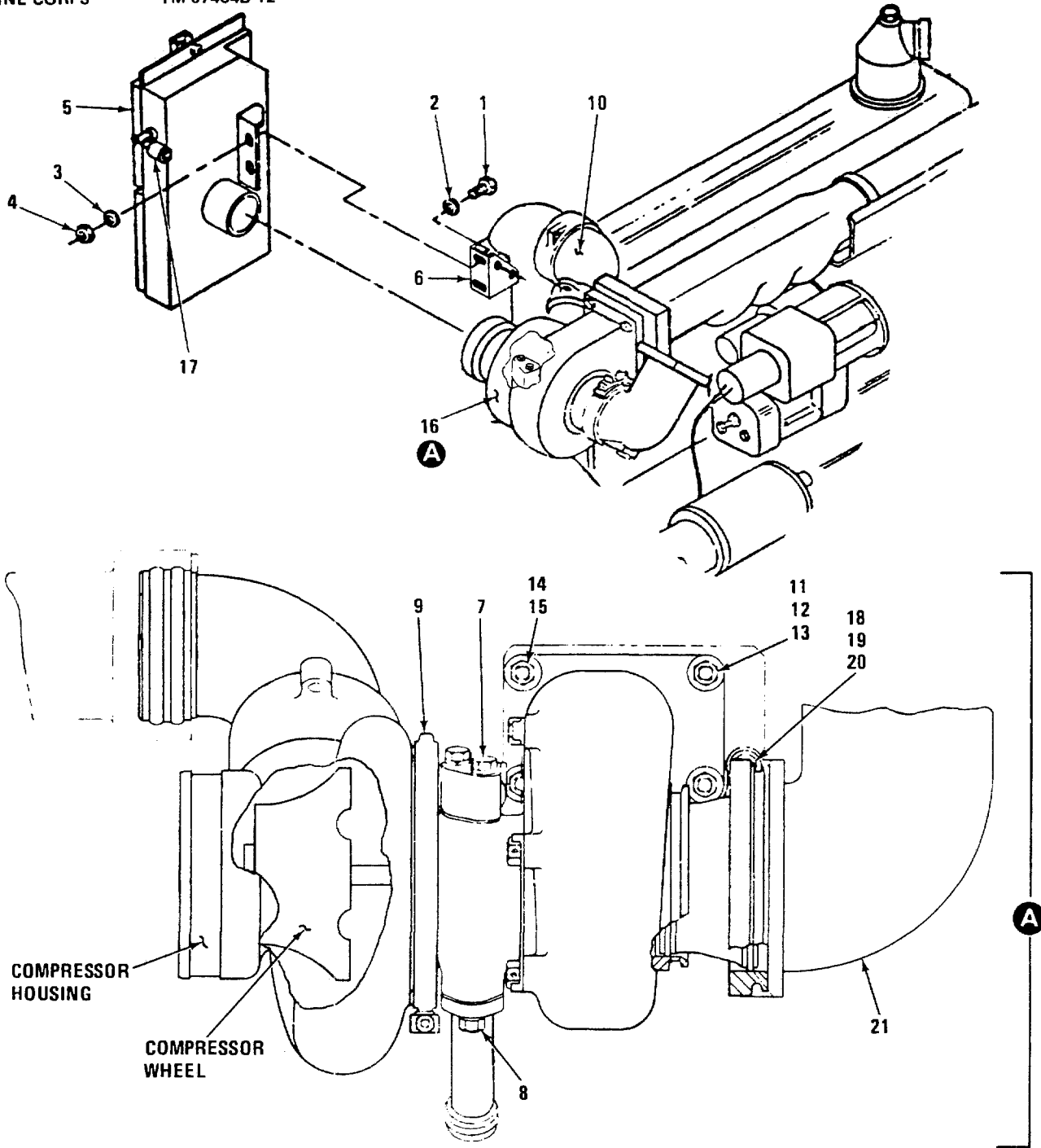

- |                         |           |                  |                     |
|-------------------------|-----------|------------------|---------------------|
| 1. SCREW                | 7. BOLT   | 12. WASHER       | 17. FILTER PRESSURE |
| 2. WASHER               | 8. BOLT   | 13. BOLT         | 18. NUT             |
| 3. WASHER               | 9. CLAMP  | 14. NUT          | 19. WASHER          |
| 4. NUT                  | 10. ELBOW | 15. WASHER       | 20. SCREW           |
| 5. AIR CLEANER ASSEMBLY | 11. NUT   | 16. TURBOCHARGER | 21. EXHAUST ELBOW   |
| 6. BRACKET              |           |                  |                     |

Figure 4-61. Turbocharger Replacement

1. BOLT
2. LOCKNUT
3. ROD
4. FUEL INJECTION PUMP LEVER
5. BOLT
6. WASHER
7. LOCKNUT
8. GOVERNOR CONTROL LEVER
9. MANUAL SHUTDOWN LEVER
10. FUEL SHUTDOWN SOLENOID L1

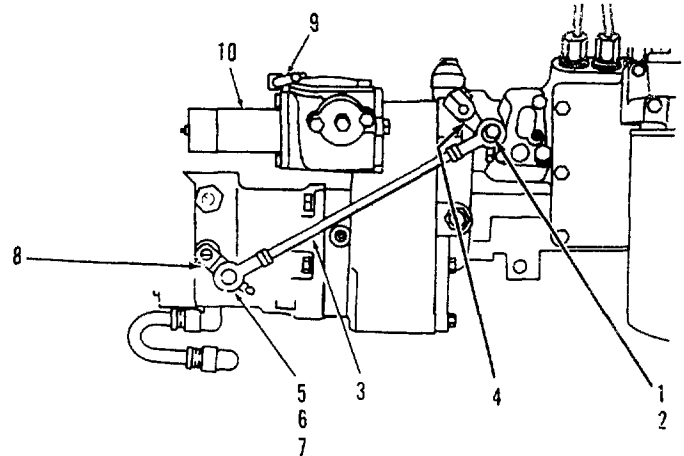

Figure 4-62. Governor Throttle Linkage, Adjustment and Replacement

(3) Attach rod (3) to governor control lever (8) using bolt (5), washer (6), and locknut (7).

(4) Perform throttle linkage adjustment (see step a, above).

(5) Attach rod (3) to fuel injection pump lever (4) using bolt (1) and locknut (2).

#### 4-118. GOVERNOR.

a. Inspect. Inspect governor for loose mounting or connections, cracking, bending, or other signs of damage or deformity.

b. Adjustment. The speed adjusting screw on the mechanical governor is located above the governor control lever. Minor adjustments to the speed of the engine can be made by

turning this screw. Refer to paragraph 4-117a, above, to adjust the governor throttle linkage.

c. Remove. Remove and replace the governor as follows (see figure 4-63):

(1) Remove bolt (1) which holds linkage rod (2) to fuel injection pump lever (3).

(2) Tag and disconnect wires to shutoff solenoid (4).

(3) Remove oil line (5) and plug opening.

(4) Remove nuts (6), bolt (7), nut (8), and washers (9). Remove the governor (10).

(5) Remove bolts (11 and 12) to remove adapter assembly (13).

(6) Remove the bolts (15) holding base (14) to cover (16). Remove the base (14).

(7) Remove bolts (17 and 18) securing support (19) to engine block and housing (20). Remove support (19) and cover (16).

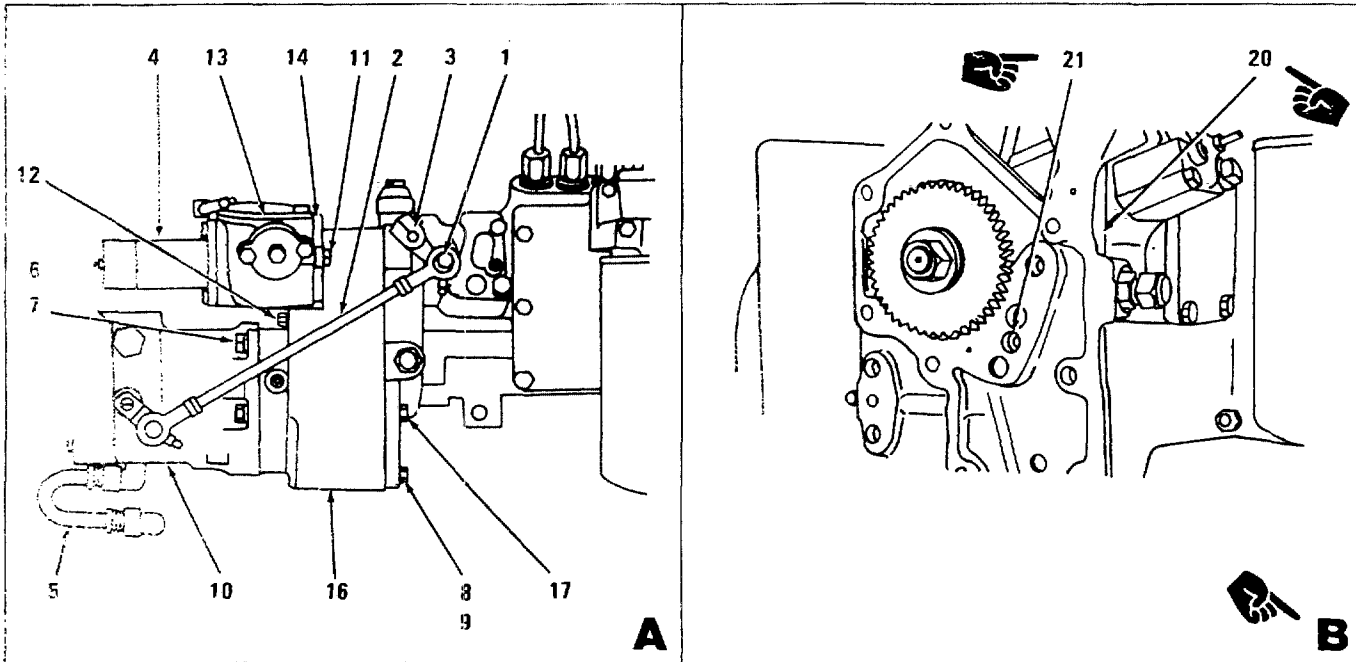

- |                              |                      |                         |
|------------------------------|----------------------|-------------------------|
| 1. BOLT                      | 10. GOVERNOR         | 19. SUPPORT (NOT SHOWN) |
| 2. LINKAGE ROD               | 11. BOLT             | 20. HOUSING             |
| 3. FUEL INJECTION PUMP LEVER | 12. BOLT             | 21. BOLT (NOT SHOWN)    |
| 4. FUEL SHUTOFF SOLENOID L1  | 13. ADAPTER ASSEMBLY |                         |
| 5. OIL LINE                  | 14. BASE             |                         |
| 6. NUT                       | 15. BOLT (NOT SHOWN) |                         |
| 7. BOLT                      | 16. COVER            |                         |
| 8. NUT                       | 17. BOLT             |                         |
| 9. WASHER                    | 18. BOLT (NOT SHOWN) |                         |

Figure 4-63. Governor, Replacement

d. Install.

(1) Install the lever assembly (28) and shaft (27) into the fuel injection pump housing.

(2) Install adapter (26) and secure with bolts (25). Install the shaft (24).

(3) Install tubing on the housing (23); install the housing (23) and secure with bolt (22).

(4) Install support assembly (21) on housing (23).

(5) Install drive sleeve (20) on housing (23).

(6) Install the support (19) and cover (16). Secure to the engine block with bolts (17 and 18).

(7) Install the base (14) on the cover (16) and secure with bolts (15).

(8) Install the adapter assembly (13) and secure with bolts (11 and 12).

(9) Install the governor (10) and secure with nuts (6), bolt (7), nut (8), and washer (9).

(10) Remove plug and install the oil line (5).

(11) Connect wiring to fuel shutoff solenoid (4).

(12) Install linkage rod (2) of fuel injection pump lever (3) and secure with bolt (1).

(13) Perform adjustment procedures on the governor according to step b, above; and adjust the governor linkage in accordance with paragraph 4-117a.

4-119. FAN ASSEMBLY. Replace fan assembly as follows:

a. Remove fan guard in accordance with paragraph 4-106.

b. Remove screws and lockwashers (see figure 4-64).

c. Remove fan assembly.

d. Install fan assembly and secure with screws and lockwashers.

e. Install fan guard in accordance with paragraph 4-106.

4-120. OIL FILTERS. Refer to figure 4-8 for oil filter service and replacement instructions.

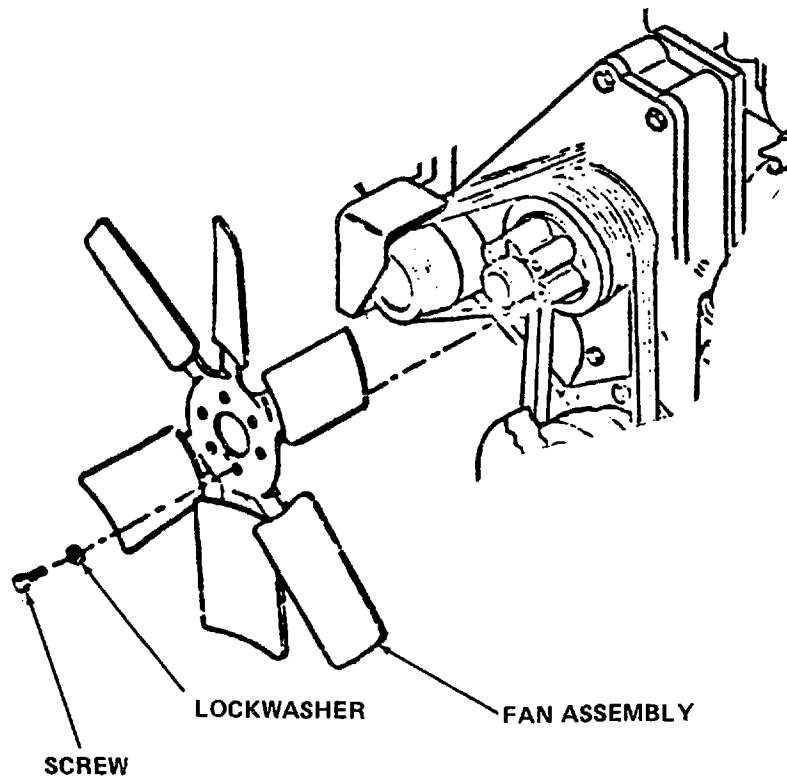
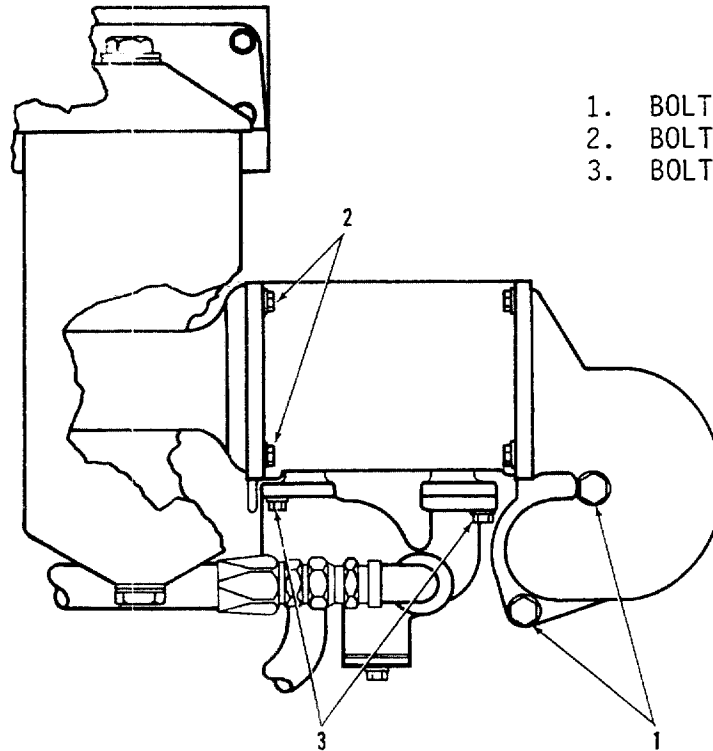

Figure 4-54. Fan Assembly, Replacement



1. BOLT
2. BOLT
3. BOLT

Figure 4-65. Oil Cooler, Replacement

#### 4-121. OIL COOLER.

a. Inspection. Inspect the oil cooler housing and all connections for cracks, leaks, dents, or other damage or deformity.

b. Replacement. Replace the oil cooler as follows:

(1) Drain coolant into a suitable container and preserve coolant for reuse. Remove coolant drain hose from oil cooler.

(2) Remove two bolts (1, figure 4-65) which hold oil cooler to cylinder block.

(3) Remove four bolts (2) which hold oil cooler to coolant inlet line.

(4) Remove four bolts (3) which hold oil cooler to bypass.

(5) Install oil cooler and secure to bypass with four bolts (3).

(6) Install four bolts (2) which secure oil cooler to coolant inlet line.

(7) Install two bolts (1) which secure oil cooler to cylinder block.

(8) Install coolant drain hose. Close coolant drain and refill cooling system in accordance with paragraph 3-14c.

#### 4-122. IDLER PULLEY ASSEMBLY.

a. Inspect. Inspect the idler pulley assembly (see figure 4-66) for cracking, bending, or other damage or deformity.

b. Replacement. Remove and replace the idler pulley assembly as follows:

(1) Remove the fan guard (see paragraph 4-106), fan (see paragraph 4-119), fan belts see (paragraph 4-107), and alternator belt (see paragraph 4-30).

(2) Remove the fan bracket bolts, lockwashers, and washers.

(3) Remove idler pulley assembly from the engine.

(4) Install idler pulley assembly onto engine and secure with fan bracket bolts, lockwashers, and washers.

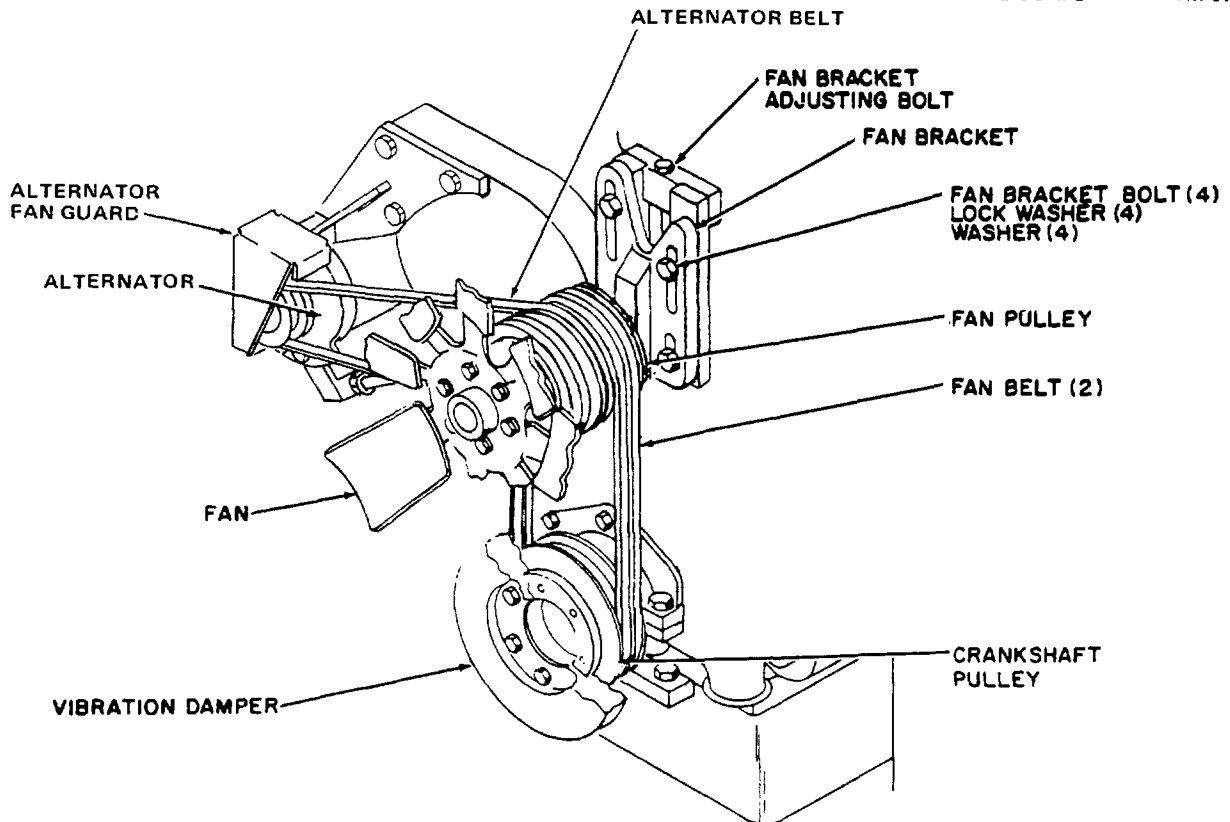

Figure 4-66. Idler Pulley Assembly, Inspection and Replacement

(5) Install alternator belt (see paragraph 4-30), fan belts (see paragraph 4-107), fan (see paragraph 4-119), and fan guard (see paragraph 4-106).

#### 4-123. EXHAUST MANIFOLD.

a. Inspect. Inspect exhaust manifold (see figure 4-67) for cracks around mounting flange bolt holes. Inspect mating surfaces for nicks and burrs.

b. Remove. Remove and replace exhaust manifold as follows:

- (1) Remove turbocharger in accordance with paragraph 4-116.
- (2) Remove bolts (1) and washers (2) to remove heat shield (3).

(3) Remove nuts (4 and 5) and washers (6 and 7).

(4) Remove front manifold (8).

(5) Remove plugs (9) from rear manifold assembly (10).

(6) Remove rear manifold assembly (10). Remove studs (11) from rear manifold (12).

(7) Remove gaskets (13).

#### c. Installation.

(1) Install new gaskets (13).

(2) Install studs (11) onto rear manifold (12). Insert plugs (9) into rear manifold assembly (10).

(3) Mount rear manifold assembly (10) and front manifold (8) onto the engine block and secure with nuts (4 and 5) and washers (6 and 7). Coat threads with antiseize compound (MIL-T-83483A). Hand torque to 32 +/- 3 foot-pounds (43.4 +/- 4 Newton-meters).

(4) Mount heat shield (3) and secure with bolts (1) and washers (2). Torque to 20 +/- 3 foot-pounds (27.12 +/- 4 Newton-meters).

(5) Install turbocharger in accordance with paragraph 4-116.

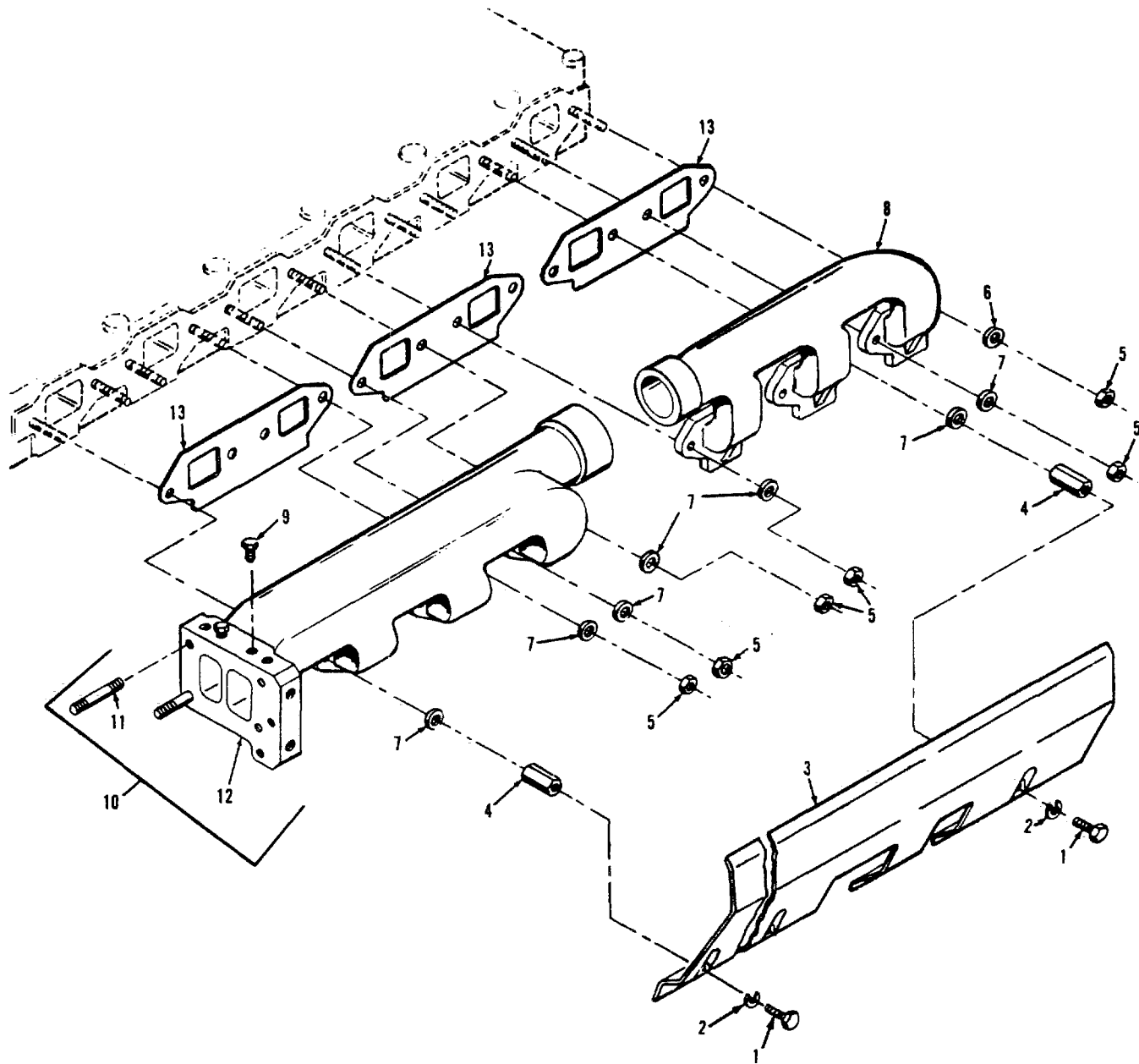

- |                |                            |
|----------------|----------------------------|
| 1. BOLT        | 7. WASHER                  |
| 2. WASHER      | 8. FRONT MANIFOLD          |
| 3. HEAT SHIELD | 9. PLUG                    |
| 4. NUT         | 10. REAR MANIFOLD ASSEMBLY |
| 5. NUT         | 11. STUD                   |
| 5. NUT         | 12. REAR MANIFOLD          |
| 6. WASHER      | 13. GASKET                 |

Figure 4-67. Exhaust Manifold, Removal and Installation



4-124. CYLINDER HEAD ASSEMBLY. Visually inspect the cylinder head assembly (see figure 4-68) while engine is operating for signs of leakage of fuel, fumes, or lubricating oil around valve cover or between the cylinder head and the spacer plate.

4-125. ROCKER ARMS AND VALVES. Remove valve cover as follows to inspect and adjust rocker arms and valves.

a. Remove Valve Cover. (See figure 4-68.)

(1) Loosen clamp to separate exhaust breather tube from the exhaust breather housing. Leave breather housing attached to valve cover.

(2) Remove bolts which secure valve cover to cylinder head assembly.

(3) Remove valve cover and gasket. Discard gasket.

b. Inspect Rocker Arms. Inspect rocker arms (see figure 4-69) for loose mounting, indications of cracking, deformity, or other damage or defects.

c. Valve Lash Adjustment. Engine valve lash should be adjusted when valves become noisy. Valve lash should be checked at 500 hours and then every 2500 hours of engine operation thereafter. Adjust valve lash as follows (see figure 4-69).

#### CAUTION

Valve lash adjustment shall be accomplished on a cold engine.

#### NOTE

Cylinders are numbered consecutively from front to rear. Exhaust valves are first valves at each cylinder as viewed from front of engine.

(1) Remove flywheel housing cover as illustrated in A, figure 4-69.

#### NOTE

When number one piston is at top dead center on compression stroke, inlet and exhaust valves for the cylinder are closed. Rocker arms for each valve are free to move the amount of the valve lash setting.

(2) Rotate engine until TC1, 6CYL marks on flywheel are aligned with timing pointer and number one piston is at top dead center on compression stroke.

(3) Adjust inlet valves of cylinders number one, two, and four to 0.015 of an inch (0.38 mm) and exhaust valves of cylinders number one, three, and five to 0.025 of an inch (0.64 mm) as follows:

(a) Insert feeler gage as shown in B, figure 4-69. Loosen locknut and rotate adjusting screw until proper clearance is obtained.

(b) Hold adjusting screw and tighten locknut to 21 +/-5 foot-pounds (28 +/-7 Newton-meters). Recheck clearance.

(4) Rotate engine 360 degrees and align TC1, 6CYL marks with timing pointer. Number six piston should be at top dead center on compression stroke.

(5) Adjust inlet valves of cylinders number three, five, and six to 0.015 of an inch (0.38 mm) and exhaust valves of cylinders number two, four, and six to 0.025 of an inch (0.64 mm). Repeat step (3)(a) and (b), above.

(6) Start engine and observe valves. Valves should rotate slightly with each opening.

d. Installation.

(1) Install valve cover assembly and gasket. Tighten cover assembly bolts to 96 +/-24 inch-pounds (10.9 +/-2.8 Newton-meters) in the sequence illustrated, figure 4-68.

(2) Install flywheel housing cover.

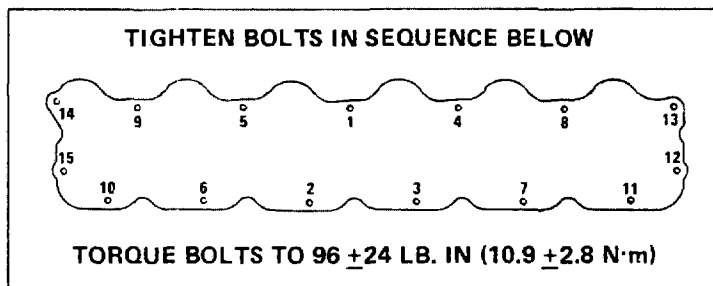
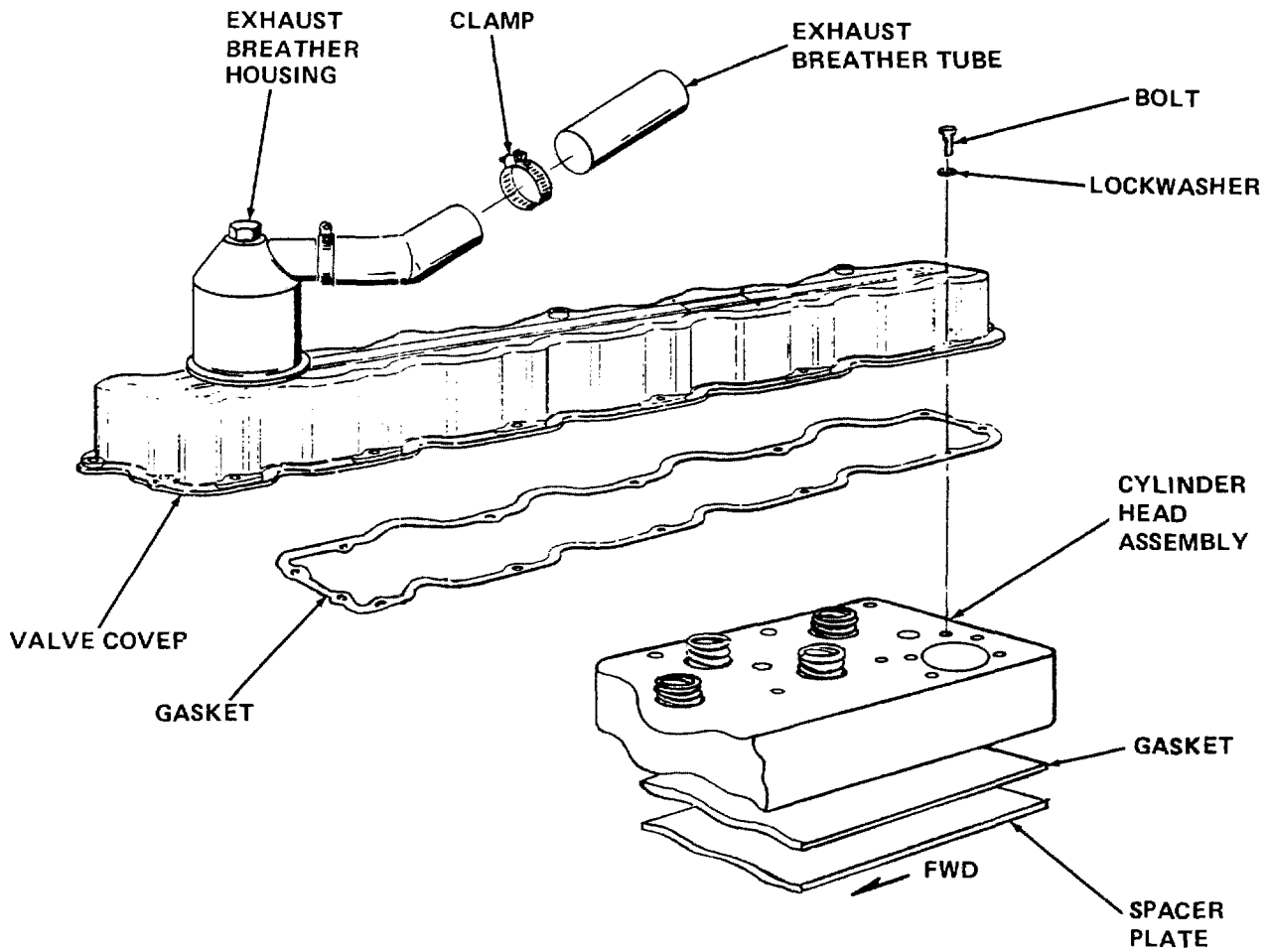

Figure 4-68. Valve Cover, Removal and Installation

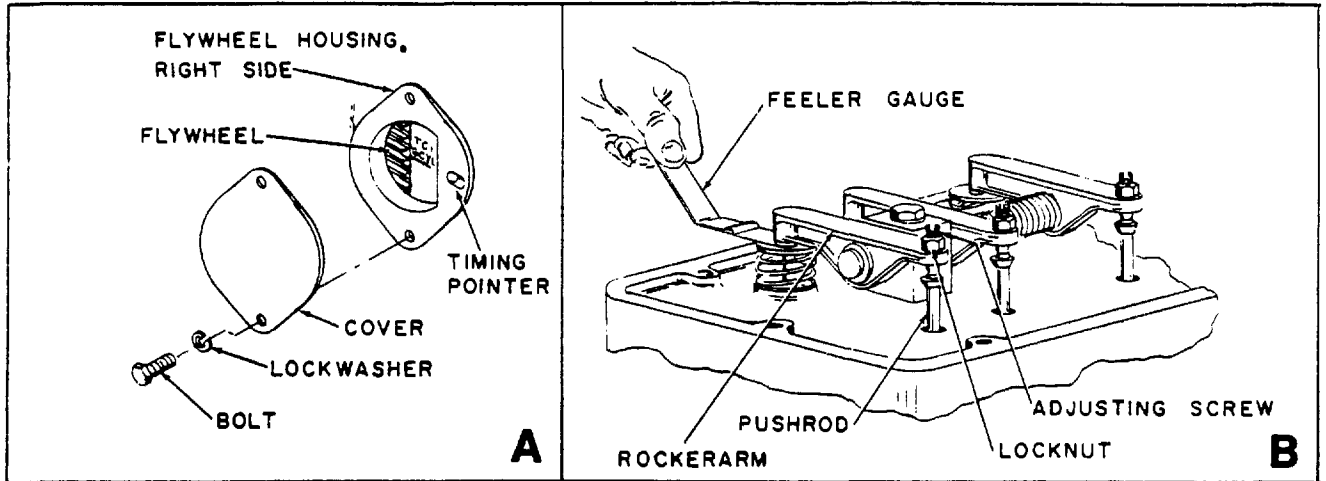

Figure 4-69. Valve Lash Adjustment



## CHAPTER 5

### AUXILIARY EQUIPMENT USED IN CONJUNCTION WITH THE END ITEM

#### Section I. FUEL BURNING WINTERIZATION KIT

5-1. GENERAL. The fuel burning winterization kit preheats the engine coolant and lubricating oil for ease of generator starting in ambient temperatures down to  $-65^{\circ}\text{F}$  ( $-53.9^{\circ}\text{C}$ ). The kit is integrally mounted in the generator set and consists of a 24-volt, fuel-fired coolant heater with integral coolant pump, control box, thermostat switch, manual shutoff valves, wiring, lines, and fittings. Heated coolant is circulated through the engine cooling system and oil pan heat exchanger by the heater coolant pump. Automatic heater cycling is controlled by the thermostat switch to prevent excessive coolant temperature. The heater is designed to operate on the same fuels as the generator set engine. The heater is mounted in the right engine compartment.

5-2. INSTALLATION. To perform the initial installation of the fuel burning winterization kit, proceed as follows:

#### WARNING

Disconnect negative cable of either battery.

a. Remove and discard plate (4, figure 2-1) by removing two screws and washers. Retain screws and washers for installing kit control box.

b. Remove protective cover from receptacle J7 on special relay box. The special relay box is mounted on top of the generator with receptacle J7 on the right side.

c. Drain the radiator (refer to paragraph 3-14c).

d. Remove plugs from engine block, then install elbow (60, figure 5-1), bushing (58).

#### NOTE

Apply thread sealing compound conforming to MIL-S-45180, Type III to all pipe threads prior to installation of elbows, bushings, and pipe connectors.

e. Remove plugs from engine oil pan heat exchanger tubes and install two female connectors (57).

f. Disconnect exhaust plate (56) by removing two existing screws (54), two existing washers (55), and two existing nuts. Discard the two nuts. Retain exhaust plate, two screws, and two washers for installing exhaust tube (43).

g. Remove existing screw, existing nut (53), and existing lockwasher (52) from front of water pump cover. Retain nut and lockwasher. Discard screw. A new (longer) screw (16) is included with the kit for later installation.

h. Remove right rear corner oil pan screw and retain for securing clamp (27).

i. Remove and discard existing plug from fuel filter and strainer tee and replace with elbow (51).

j. Install bracket (50) to skid base using two screws (49), two washers (48), and two nuts (47).

k. Install heater (46) to skid base and bracket using two screws (45), two screws (49), and four nuts (44).

l. Install heater exhaust tube (43), clamp (42), screws (54), washers (55), and exhaust plate (56) previously removed from skid base.

m. Install heater shutoff valve instruction plate (41) using two rivets (40).

REMOVE EXISTING SCREW ON FRONT OF WATER PUMP COVER AND DISCARD. REPLACE WITH SCREW (16).

CONNECT THIS END TO RECEPTACLE J7 ON SPECIAL RELAY BOX PART NO. 70-4225.

REMOVE AND DISCARD COVER PLATE PART NO. 69-769. USE EXISTING HARDWARE TO INSTALL CONTROL BOX (8).

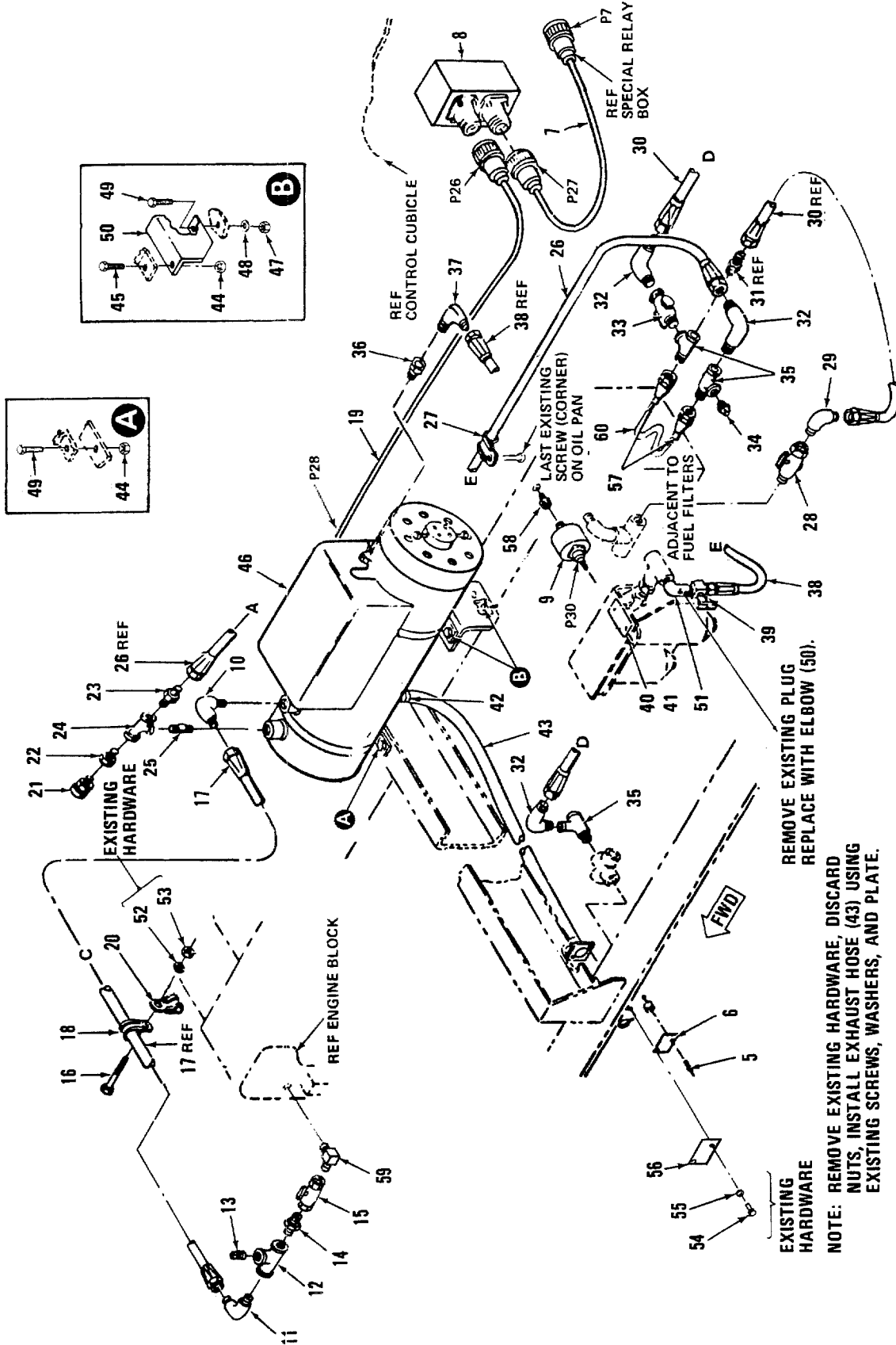

REMOVE EXISTING PLUG  
 REPLACE WITH ELBOW (50).

EXISTING HARDWARE  
 NOTE: REMOVE EXISTING HARDWARE, DISCARD NUTS, INSTALL EXHAUST HOSE (43) USING EXISTING SCREWS, WASHERS, AND PLATE.

Figure 5-1. Fuel Burning Winterization Kit, Removal and Installation (Sheet 1 of 2)

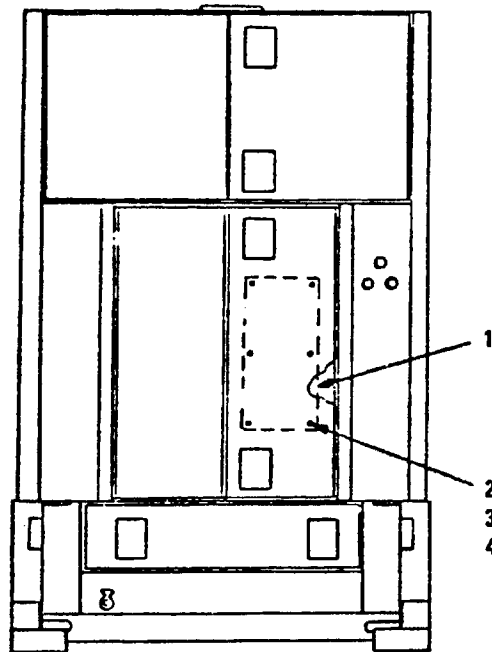

REAR VIEW OF GENERATOR SET

- |                         |                       |                    |
|-------------------------|-----------------------|--------------------|
| 1. SYSTEM DIAGRAM PLATE | 22. BUSHING           | 43. EXHAUST HOSE   |
| 2. NUT                  | 23. CONNECTOR         | 44. NUT            |
| 3. WASHER               | 24. TEE               | 45. SCREW          |
| 4. SCREW                | 25. NIPPLE            | 46. HEATER ASSY    |
| 5. RIVET                | 26. HOSE ASSY         | 47. NUT            |
| 6. ID PLATE             | 27. CLAMP             | 48. WASHER         |
| 7. HARNESS ASSY         | 28. VALVE             | 49. SCREW          |
| 8. CONTROL BOX          | 29. ELBOW             | 50. BRACKET        |
| 9. THERMOSTAT SWITCH    | 30. HOSE ASSY         | 51. ELBOW          |
| 10. ELBOW               | 31. CONNECTOR         | 52. LOCKWASHER     |
| 11. ELBOW               | 32. ELBOW             | 53. NUT            |
| 12. TEE                 | 33. DRAIN VALVE       | 54. SCREW          |
| 13. PLUG                | 34. PLUG              | 55. WASHER         |
| 14. NIPPLE              | 35. TEE               | 56. EXHAUST PLATE  |
| 15. VALVE               | 36. ADAPTER           | 57. CONNECTOR      |
| 16. SCREW               | 37. ELBOW             | 58. BUSHING        |
| 17. HOSE ASSY           | 38. HOSE ASSY         | 59. ELBOW          |
| 18. CLAMP               | 39. VALVE             | 60. HEAT EXCHANGER |
| 19. HARNESS ASSY        | 40. RIVET             |                    |
| 20. CLAMP               | 41. INSTRUCTION PLATE |                    |
| 21. RELIEF VALVE        | 42. CLAMP             |                    |

Figure 5-1. Fuel Burning Winterization Kit,  
Removal and Installation (Sheet 2 of 2)

- n. Install needle valve (39), hose assembly (38), elbow (37), and adapter (36).
- o. Install three pipe tees (35), plug (34), drain valve (33), three elbows (32), connector (31), two hose assemblies (30), elbow (29), and drain valve (28).
- p. Slide clamp (27) onto hose assembly (26), then secure clamp to oil pan using screw previously removed from oil pan. Secure hose assembly (26) to elbow (32). Install nipple (25), tee (24), and connector (23). Secure remaining end of hose assembly (26) to connector (23).
- q. Install bushing (22) and relief valve (21).
- r. Slide clamp (20) over wiring harness (19), and slide clamp (18) over hose assembly (17). Secure clamps (20 and 18) with screw (16), washer (52), and nut (53) previously removed from water pump.
- s. Install valve (15), nipple (14), plug (13), tee (12), elbow (11), and elbow (10), then secure one end of hose assembly (17) to elbow (11) and the other end to elbow (10).
- t. Install coolant thermostat switch (9).
- u. Install control box (8) using hardware previously removed with cover plate.
- v. Connect plug P26 of harness assembly (7) to upper receptacle J26 on control box (8). Connect plug P7 to receptacle J7 on the special relay box.
- w. Connect plug P27 of harness assembly (19) to the lower receptacle J27 on control box (8). Connect plug P28 to heater (46) and plug P30 to thermostat switch (9).

WARNING

Drilling operations create metal chips that may enter the eye. Wearing of goggles is required.

- x. Position identification plate (6) next to exhaust hole and use identification plate as a template to

- drill two 0.156-inch (3.96 mm) diameter holes. Secure identification plate (6) with two rivets (5).
- y. Position system diagram plate (1) inside right air intake door. Use system diagram plate as a template and drill six 0.156-inch (3.96 mm) diameter holes. Secure plate (1) with six screws (4), six flat washers (3), and six nuts (2).
- z. Close coolant drain valve (33) and open coolant valves (15) and (28).
- aa. Service radiator with arctic antifreeze compound conforming to MIL-A-11755 (refer to paragraph 3-14b).
- ab. Reconnect battery cable.

5-3. LUBRICATION. No lubrication of the fuel burning winterization kit is required.

5-4. PREVENTIVE MAINTENANCE CHECKS AND SERVICES (PMCS).

- a. General. To ensure that the fuel burning winterization kit is ready for operation at all times, it must be inspected systematically so defects may be discovered and corrected before they result in serious damage or failure. The necessary preventive maintenance checks and services that are to be performed by operator personnel are: inspection of fuel and coolant lines; inspection of valves; checking radiator coolant level; and inspection of generator set doors, heater exhaust, and fuel transfer pump for leakage. Preventive maintenance checks and services to be performed by organizational maintenance are: tightening of clamps and attaching hardware, inspection of wiring harnesses, and testing of the thermostat switch. Defects discovered during operation will be noted for future correction. Stop operation immediately if a deficiency is noted which would damage the equipment. All deficiencies and short-comings will be recorded together with the corrective



actions taken on the applicable form. Air Force users shall refer to the applicable inspection manuals and work card sets in the TO 35C2-3 for periodic requirements and tables 5-1 and 5-2 for detailed procedures.

b. (A, N, MC) Preventive Maintenance Checks and Services. Table 5-1 contains a tabulated listing

of the PMCS which shall be performed by operator personnel. Table 5-2 contains a tabulated listing of the PMCS which shall be performed by organizational personnel. The item numbers in each table are listed consecutively and indicate the sequence of minimum requirements.

Table 5-1. Fuel Burning Winterization Kit, Operator/Crew Preventive Maintenance Checks and Services

INTERVAL			B - BEFORE OPERATION D - DURING OPERATION A - AFTER OPERATION DAILY - 8HRS	TOTAL T/H: 1.0
OPERATOR			ITEMS TO BE INSPECTED. INSPECTION PROCEDURES.	WORK TIME T/H
DAILY				
B	D	A		
1			HEATER ASSEMBLY Check for leaks, loose electrical connector, damage, and deformation (refer to figure 5-1).	0.2
2			FUEL AND COOLANT LINES Check for leaks, damage, and deformation (refer to figure 5-1).	0.2
3			HEATER FUEL SHUTOFF AND COOLANT VALVES Inspect valves (28, 33, 39, and 60) for leakage.	0.1
4			GENERATOR SET RADIATOR Check for proper coolant level (paragraph 3-14b).	0.1
5			GENERATOR SET DOORS Inspect door seals for proper sealing.	0.1
	6		HEATER EXHAUST Inspect for leaks or damage (43, figure 5-1).	0.1
	7		GENERATOR SET FUEL TRANSFER PUMPS Check transfer pumps for leaks.	0.1
	8		FUEL AND COOLANT LINES AND VALVES Check for leakage during operation (refer to figure 5-1).	0.1

Table 5-2. Fuel Burning Winterization Kit, Organizational Preventive Maintenance Checks and Services

INTERVAL			W - WEEKLY (40 HRS)	TOTAL T /H: 0.0
			M - MONTHLY (100 HRS)	TOTAL T /H: 0.1
			S - SEMI-ANNUALLY (500 HRS)	TOTAL T /H: 1.0
ORGANIZATION			INSPECTION PROCEDURES	WORK TIME T/H
W	M	S		
	1		THERMOSTAT SWITCH Inspect thermostat switch (refer to paragraph 5-16a).	0.1
		2	CLAMPS AND ATTACHING HARDWARE Tighten all hardware (refer to figure 5-1).	0.1
		3	COOLANT AND FUEL LINES Tighten lines and check condition (refer to figure 5-1).	0.2
		4	WIRING HARNESSSES Inspect for frayed insulation and security of connectors (refer to figure 5-1).	0.1
		5	THERMOSTAT SWITCH Test switch for proper operation (refer to paragraph 5-16b). Replace thermostat if defective.	0.2
		6	REGULATOR VALVE ASSEMBLY Adjust regulator valve assembly (refer to paragraph 5-9).	0.2
		7	IGNITER ASSEMBLY Inspect and replace, if required (refer to paragraph 5-13).	0.2

5-5. TROUBLESHOOTING.

a. This section contains troubleshooting information for locating and correcting operating troubles which may develop in the generator set. Table 5-3 is applicable to the operator. Table 5-4 contains organizational

troubleshooting procedures. Each malfunction for an individual component unit, or system is followed by a list of tests or inspections which will help you to determine probable causes and corrective actions to take. Perform the tests/inspections and corrective actions in the order listed.

b. This manual cannot list all malfunctions that may occur, nor all tests or inspections and corrective actions. If a malfunction is not listed or cannot be corrected by listed corrective actions, notify your supervisor.

**NOTE**

Before you use table 5-3, be sure you have performed all applicable operating checks.

5-6. OPERATOR MAINTENANCE PROCEDURES. The following maintenance procedures are to be performed by operator personnel.

a. Inspect. Visually inspect the heater assembly (46, figure 5-1) for cracks in the case, security of attachment, and other damage. Inspect coolant and fuel lines for blistering or cracks. Ensure that all lines and fittings are secure, and that there are no signs of leakage or restrictions when the system is operating.

b. Service.

(1) Remove protective cover (1, figure 5-2) by loosening two captive screws.

(2) Disconnect burner fuel line (2) and remove metering orifice assembly (3).

(3) Remove filter body (4) with gasket (5) and sintered filter (6) from heater assembly.

(4) Unscrew sintered filter (6) from filter body (4). Discard gasket (5).

**WARNING**

Dry cleaning solvent, P-D-680, Type II, is flammable and moderately toxic to the skin, eyes, and respiratory tract. Skin, eye, and respiratory protection is required.

**WARNING**

Compressed air used for cleaning or drying can create airborne particles to may enter the eyes. Pressure shall not exceed 30 psig (206 kPa). Wearing of goggles is required.

(5) Clean metering orifice assembly (3) and sintered filter (6) with cleaning solvent, (P-D-680, Type II) and dry with filtered compressed air.

(6) Hold orifice up to light and check to make sure its pin hole is unobstructed.

(7) Screw sintered filter (6) into filter body (4) and install with new gasket (5) into heater assembly.

**CAUTION**

Use extreme care when installing the orifice assembly. Its pin hole can easily be clogged by any small particle of foreign matter.

(8) Install metering orifice assembly (3) and connect burner fuel line (2).

(9) Install protective cover (1) by tightening two captive screws.

c. Test. Test the lamp on the fuel burning winterization kit control box by energizing the circuit breaker and pressing the PRESS-TO-TEST INDICATOR (refer to figure 2-12).

5-7. ORGANIZATIONAL MAINTENANCE PROCEDURES. The maintenance procedures of paragraphs 5-8 through 5-21 are to be performed by the organizational level of maintenance.

5-8. HEATER ASSEMBLY. The heater is a fuel burning type designed to preheat the engine for starting at low temperatures down to -65°F (-53.9°C) by circulating heated coolant through the engine. The heater consists of a

Table 5-3. Fuel Burning Winterization Kit,  
Operator/Crew Troubleshooting

---

MALFUNCTION  
TEST OR INSPECTION  
CORRECTIVE ACTION

---

1. PRESS-TO-TEST LIGHT DOES NOT LIGHT WHEN PRESSED.

Step 1. Check that circuit breaker is energized.

Energize circuit breaker (see figure 2-12).

Step 2. Test lamp (refer to paragraph 5-6c).

Replace lamps; refer to next higher maintenance.

2. CONTROL BOX ON-OFF SWITCH POSITIONED TO ON BUT HEATER DOES NOT OPERATE.

Step 1. Check that circuit breaker is energized.

Energize circuit breaker (see figure 2-12).

3. HEATER STARTS BUT WILL NOT IGNITE.

Step 1. Check that fuel shutoff valve (39, figure 5-1) is open.

Open valve.

Step 2. Check generator set fuel supply.

Service fuel tank (refer to paragraph 3-11e).

Step 3. Inspect fuel lines for damage or restrictions.

Refer broken or damaged lines to organizational maintenance.

Step 4. Service heater assembly (refer to paragraph 5-6b).

4. COOLANT PUMP HAS LOW OR NO OUTPUT.

Step 1. Check that coolant valves (15 and 28, figure 5-1) are open.

Open valves.

Step 2. Check coolant lines for damage or restrictions.

Refer broken or damaged lines to next higher maintenance.

---

Table 5-4. Fuel Burning Winterization Kit,  
Organizational Troubleshooting

---

MALFUNCTION  
TEST OR INSPECTION  
CORRECTIVE ACTION

---

1. PRESS-TO-TEST LIGHT DOES NOT LIGHT WHEN PRESSED.

Step 1. Inspect wiring harness (19, figure 5-1).

Repair or replace wiring harness.

Step 2. Inspect and test control box (8, figure 5-1).

Replace control box (refer to paragraph 5-18d).

2. CONTROL BOX ON-OFF SWITCH POSITIONED TO ON BUT HEATER DOES NOT OPERATE.

Step 1. Test batteries (refer to paragraph 3-9a).

Service or replace batteries as required (refer to paragraph 3-9a and Section IX of Chapter 4).

Step 2. Inspect wiring harnesses (7 and 19, figure 5-1).

Repair or replace defective harnesses as required (refer to paragraph 5-15).

Step 3. Inspect and test control box (refer to paragraph 5-18).

Replace defective control box (refer to paragraph 5-18d).

Step 4. Test engine heater (refer to paragraph 5-8a).

Replace defective heater; refer to higher maintenance.

3. HEATER STARTS BUT WILL NOT IGNITE.

Step 1. Test electric fuel transfer pumps (refer to Section XII of Chapter 4).

Replace defective pumps (refer to Section XII of Chapter 4).

Step 2. Inspect igniter assembly (refer to paragraph 5-13a).

Replace defective igniter assembly (refer to paragraph 5-13b).

Table 5-4. Fuel Burning Winterization Kit,  
Organizational Troubleshooting (Continued)

---

MALFUNCTION  
TEST OR INSPECTION  
CORRECTIVE ACTION

---

3. HEATER STARTS BUT WILL NOT IGNITE (Continued).

Step 3. Heater overheat switch tripped.

Permit heater to cool and restart (refer to figure 2-12).

Step 4. Test engine heater (refer to paragraph 5-8a).

Replace defective heater; refer to higher maintenance.

Step 5. Inspect and test thermostat switch (refer to paragraph 5-16).

Replace defective thermostat switch (refer to paragraph 5-16).

4. HEATER COMBUSTION SURGES.

Step 1. Inspect fuel lines restriction (refer to paragraph 5-6a).

Replace defective fuel lines (refer to paragraph 5-17a).

Step 2. Test electric fuel transfer pumps (refer to Section XII of Chapter 4).

Replace defective pumps (refer to Section XII of Chapter 4).

Step 3. Inspect igniter assembly (refer to paragraph 5-13a).

Replace defective igniter assembly (refer to paragraph 5-13b).

5. HEATER WILL NOT SHUT OFF WHEN ON-OFF SWITCH IS POSITIONED TO OFF (AFTER PURGE CYCLE).

Step 1. Inspect and test control box (refer to paragraph 5-18).

Replace defective control box (refer to paragraph 5-18d).

Step 2. Inspect wiring harnesses (7 and 19, figure 5-1).

Repair or replace defective harnesses as required (refer to paragraph 5-15).

Step 3. Test engine heater (refer to paragraph 5-8a).

Replace defective heater; refer to higher maintenance.

---

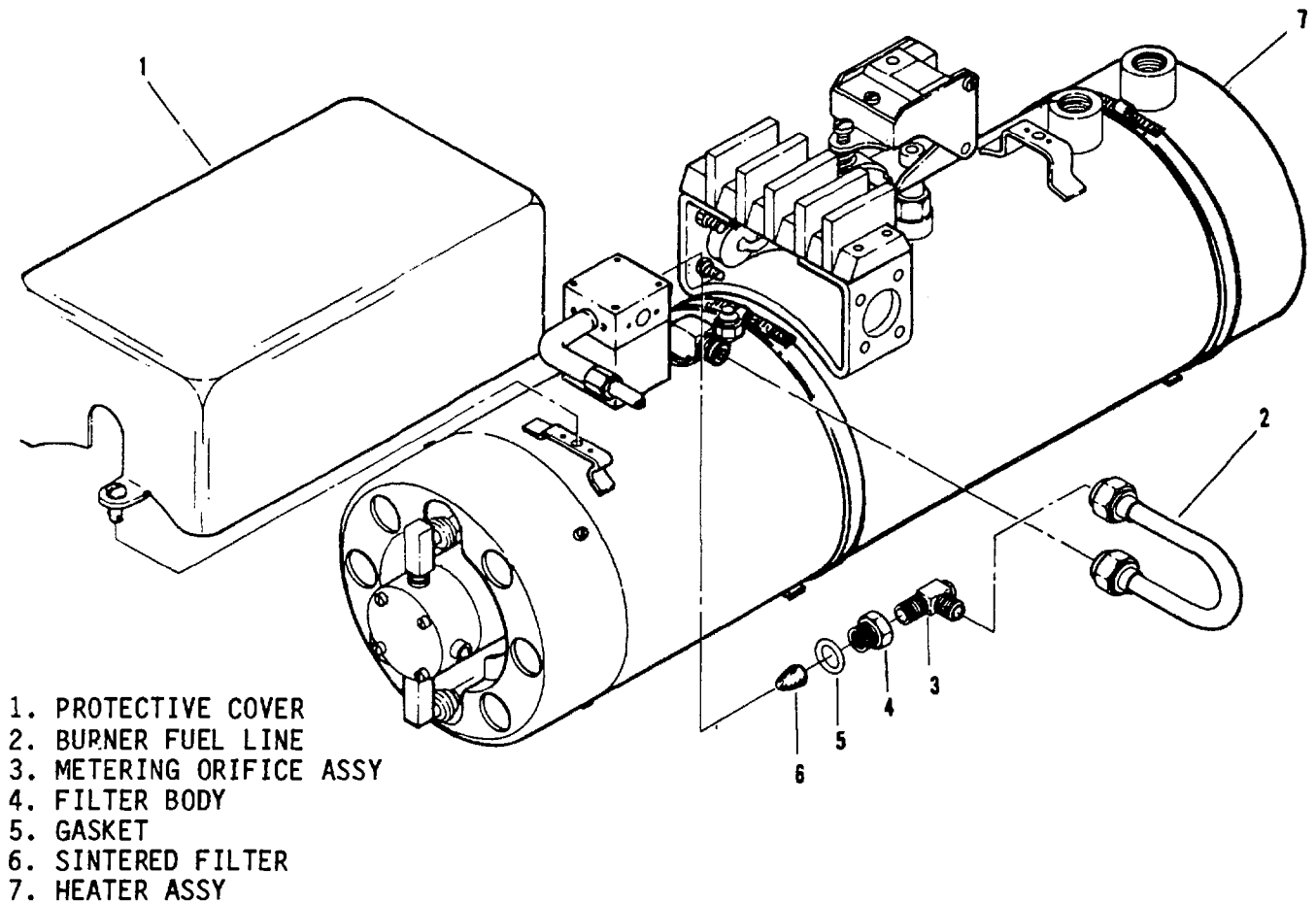

Figure 5-2. Fuel Burning Winterization Kit Heater Assembly, Service

blower motor, fuel regulator valve, limit switch, igniter, flame switch, and a coolant pump. The blower motor and fan assembly provides air for combustion; it is also a means for driving the coolant pump. The fuel regulator valve permits the fuel to be turned on and off; it also regulates the fuel flow to the burner. The igniter, which is a high-resistance glow plug, is used to vaporize and ignite the fuel. The flame switch controls the electrical supply to the igniter, blower motor, and indicator lamp; its operation is determined by temperature. Recirculation of heated coolant is provided by the coolant pump at a rate of 80 to 100 gph (302 to 378 liters per hour). Coolant is circulated around the heater combustion chamber where it is heated

and then circulated through the engine. The following paragraphs provide test and adjustment procedures for the heater assembly.

a. **Test.** Refer to paragraph 2-8 and operate the heater assembly to determine if heater is operational.

b. **Adjust.** Refer to paragraph 5-9 for adjustment procedures for the regulator valve, and paragraph 5-14b for adjustment of the flame switch.

5-9. **REGULATOR VALVE ASSEMBLY.** Adjust the regulator valve assembly (see figure 5-3) as follows:

a. Service the heater assembly as specified in paragraph 5-6b. Do not install burner fuel line or protective cover.

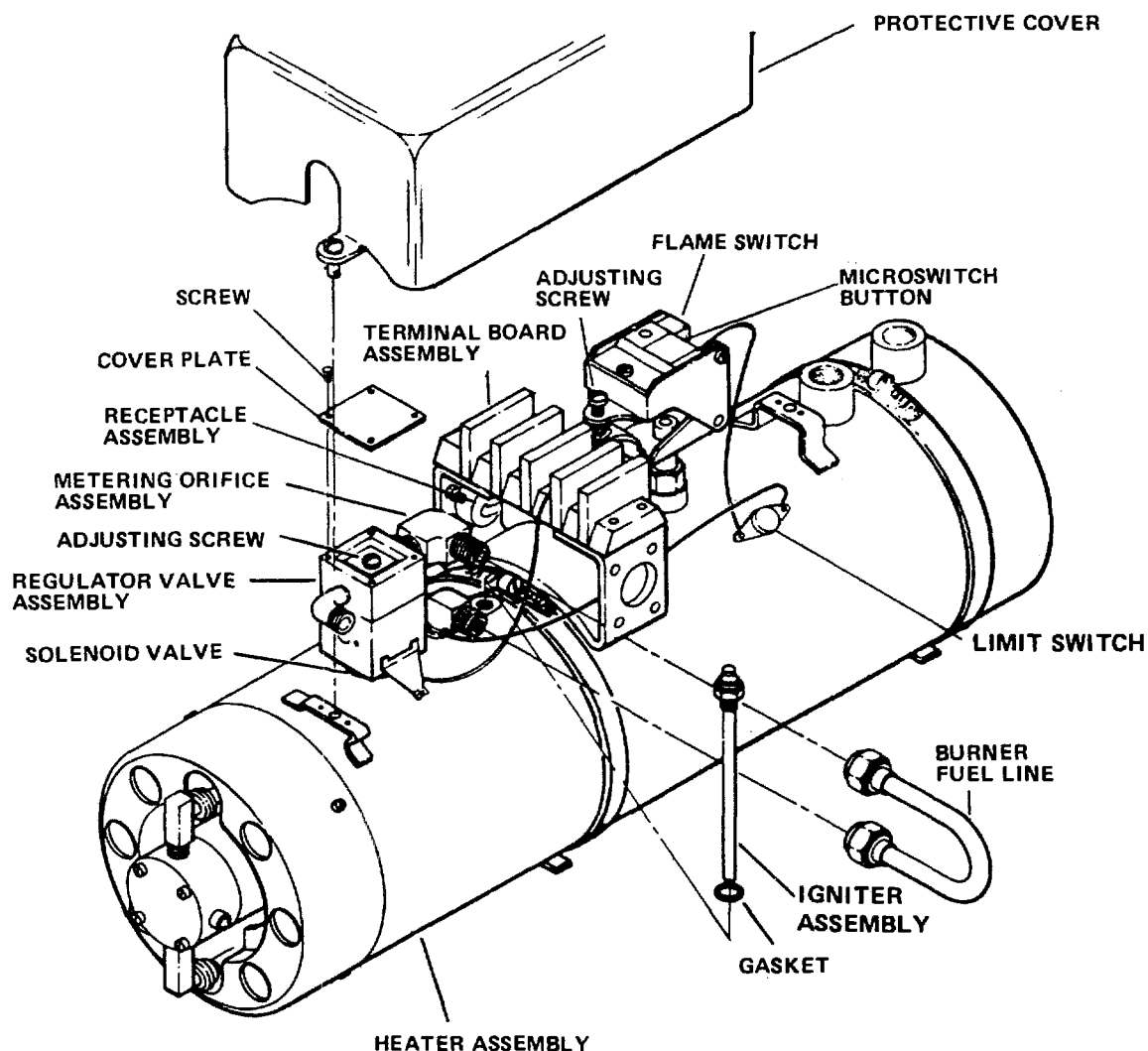

Figure 5-3. Fuel Burning Winterization Kit Heater Assembly, Maintenance

b. Disconnect and tag electrical lead to igniter assembly.

c. Remove cover plate by loosening four screws to expose brass adjusting screw.

d. Connect one end of burner fuel line onto metering orifice assembly and position the other end to drain into a graduated container.

e. Install a jumper wire across terminals of thermostat switch (9, figure 5-1).

f. With fuel inlet line connected and fuel at the valve, place heater assembly into operation (refer to paragraph 2-8).

g. Using a stop watch, time the fuel flow into graduated container. Flow should measure 1/2 pint (0.25 liter) in 10 to 12 minutes.

h. If flow is not within specified limits, rotate adjusting screw (figure 5-3) to obtain proper flow rate.



NOTE

Rotating adjusting screw clockwise increases flow rate; rotating adjusting screw counterclockwise decreases flow rate.

i. Stop heater assembly operation (refer to paragraph 2-8).

j. Install burner fuel line (figure 5-3).

k. Install cover plate and secure with screws.

l. Install igniter assembly electrical lead.

m. Install heater assembly protective cover by tightening two captive screws.

n. Remove jumper wire from thermostat switch.

5-10. TERMINAL BOARD. Inspect the terminal board (see figure 5-3) for cracks, carbon deposits on terminals, loose connections, or other obvious damage.

5-11. LIMIT SWITCH. The following paragraphs provide inspection and test procedures for the limit switch (see figure 5-3).

a. Inspect. Inspect the switch for secure mounting, cracks, corrosion and evidence of shorting or damage.

b. Test.

(1) Remove protective cover (figure 5-3) by loosening two captive screws.

(2) Tag and disconnect electrical leads to switch.

(3) Using a multimeter, check switch for continuity.

(4) Reconnect electrical leads to switch.

(5) Install protective cover by tightening two captive screws.

5-12. RECEPTACLE ASSEMBLY. The following paragraphs provide inspection, test, and replacement procedures for the receptacle assembly (figure 5-3)

a. Inspect. Inspect the receptacle assembly for loose connections and bent or broken terminal pins.

b. Test. Using an ohmmeter, test for short to case and surrounding pins. Test for continuity between wires and terminal pins.

c. Replace.

(1) Remove protective cover by loosening two captive screws.

(2) Remove four screws which secure receptacle assembly.

(3) Tag and disconnect leads from receptacle.

(4) Install new receptacle assembly using four screws.

(5) Remove tags and connect leads.

(6) Reinstall protective cover by tightening two captive screws.

5-13. IGNITER ASSEMBLY. The following paragraphs provide inspection and replacement procedures for the heater igniter assembly (see figure 5-4).

a. Inspect. Remove the igniter in accordance with paragraph 5-13b, below, and inspect for deterioration, cracks, or other obvious damage.

b. Replace. Refer to figure 5-4 and proceed as follows:

(1) Release two captive screws to remove protective cover.

(2) Lift off cover, then remove nut and lead from igniter.

(3) Remove gasket.

(4) Install new gasket and igniter, then reinstall lead and securely tighten nut.

(5) Reinstall protective cover by tightening two captive screws.

5-14. FLAME SWITCH. The following paragraphs provide test and adjustment procedures for the flame switch (see figure 5-3).

a. Test.

(1) Remove protective cover by releasing the two captive screws.

(2) Depress the microswitch button. This will be the ignition or

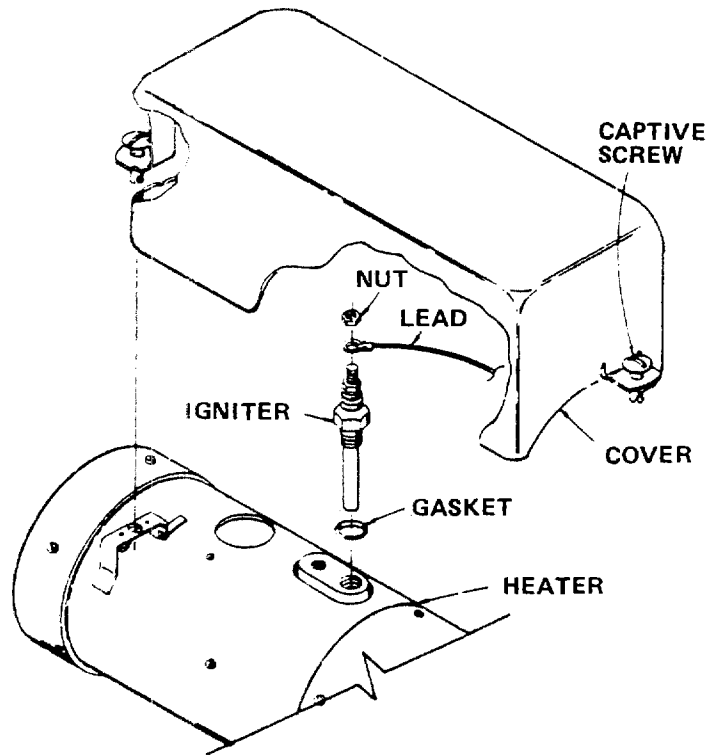

Figure 5-4. Fuel Burning Winterization Kit, Igniter Replacement

start position of the switch. Continuity should be indicated between the two normally open terminals and also between each of the normally open terminals and the common terminal. There should be an open circuit between the two normally closed terminals and also between the common terminal and the two normally closed terminals.

(3) Release the microswitch button. This will be the run position of the microswitch. Continuity should be indicated between the two normally closed terminals and the common terminal. There should be an open circuit between the normally open ignition or start terminals and between the normally open terminals and the common terminal.

(4) If switch is defective, refer to next higher maintenance for replacement.

(5) Replace protective cover by tightening two captive screws.

b. Adjust.

(1) Remove protective cover (see figure 5-3) by loosening two captive screws.

(2) Rotate flame switch adjusting screw counterclockwise until heater motor starts.

(3) Rotate adjusting screw clockwise until motor stops.

(4) Give adjusting screw an additional 1/2 (180 degree) turn.

(5) Reinstall protective cover by tightening two captive screws.

5-15. WIRING HARNESES. Two wiring harnesses are used in conjunction with the fuel burning winterization kit (7 and 19, figure 5-1). Harness (7) interconnects the control box with the special relay box. Harness (19) interconnects the ON-OFF switch on the control box with the engine heater and the coolant thermostat switch.

a. Inspect. Inspect both harnesses for frayed insulation and damaged connectors.

b. Test. Perform continuity check using an ohmmeter between connecting points in the wiring harness (refer to figures 5-5 and 5-6). Check for short circuits between pins of the same connector.

c. Replace. Uncouple connectors at ends of harnesses, remove clamps, then install new harnesses (refer to figure 5-1).

d. Repair. Repair wiring harness by accomplishing the most efficient repair procedure listed below.

WARNING

Disconnect negative battery cable.

CAUTION

Under no conditions leave bare connection exposed.

NOTE

Repair procedure may be accomplished with harness installed in generator.

(1) Disconnect and, if possible, remove defective wire. Connect new wire of same size and type to terminals from which defective wire was removed. Attach new wire to harness using tiedown straps.

(2) Remove defective portion of wire and connect wire ends with a solderless wire connector.

(3) Replace defective terminal lugs or connectors.

(4) If disconnected, connect negative battery cable.

5-16. THERMOSTAT SWITCH. The following paragraphs provide inspection, test, and replacement procedures for the thermostat switch (9, figure 5-1).

a. Inspect. Inspect switch for cracked, loose, or damaged case. Ensure that connector receptacle is securely mounted and that plug P30 is securely attached.

b. Test. Remove switch as described in paragraph 5-16c, below, then proceed as follows:

(1) Fill a suitable container with water and place thermometer in container. Place temperature sensing end of switch in water.

(2) Heat water and check for continuity using an ohmmeter. There should be continuity between pins A and B up to 125 +5°F (51.6 +2°C) and no continuity at temperatures higher than 125 +5°F (51.6 +2°C).

(3) Permit water to cool. Contacts should close (meter indicates continuity) at 50 + 5°F (10 + 1°C).

(4) Remove switch from test equipment. If switch is defective, replace it in accordance with paragraph 5-16c, below.

c. Replace. Remove electrical connector P30 from switch, then unscrew the switch from the engine housing. If switch is not being replaced immediately, temporarily plug engine opening.

5-17. HOSES, LINES, AND FITTINGS. The following paragraphs provide replacement and rebuild instructions for the fuel burning winterization kit hoses, lines, and fittings (refer to figure 5-1).

a. Replace.

(1) Replace exhaust hose (43) by removing two screws (54), two washers (55), and clamp (42). Install new exhaust hose using screws (54), washers (55), and clamp (42).

(2) Close valves (15 and 28). Place a suitable container under valve (33), then open valve.

(3) Replace hose assemblies (17, 26, 30, and 38) by unscrewing couplings at each end of hose

WIRE LENGTH TOLERANCES		
OVER	INCL	TOL ±
0	.50	.12
.50	2	.19
2	6	.25
6	12	.38
12	36	.50
36	100	1
100	200	1.50
200	UP	2

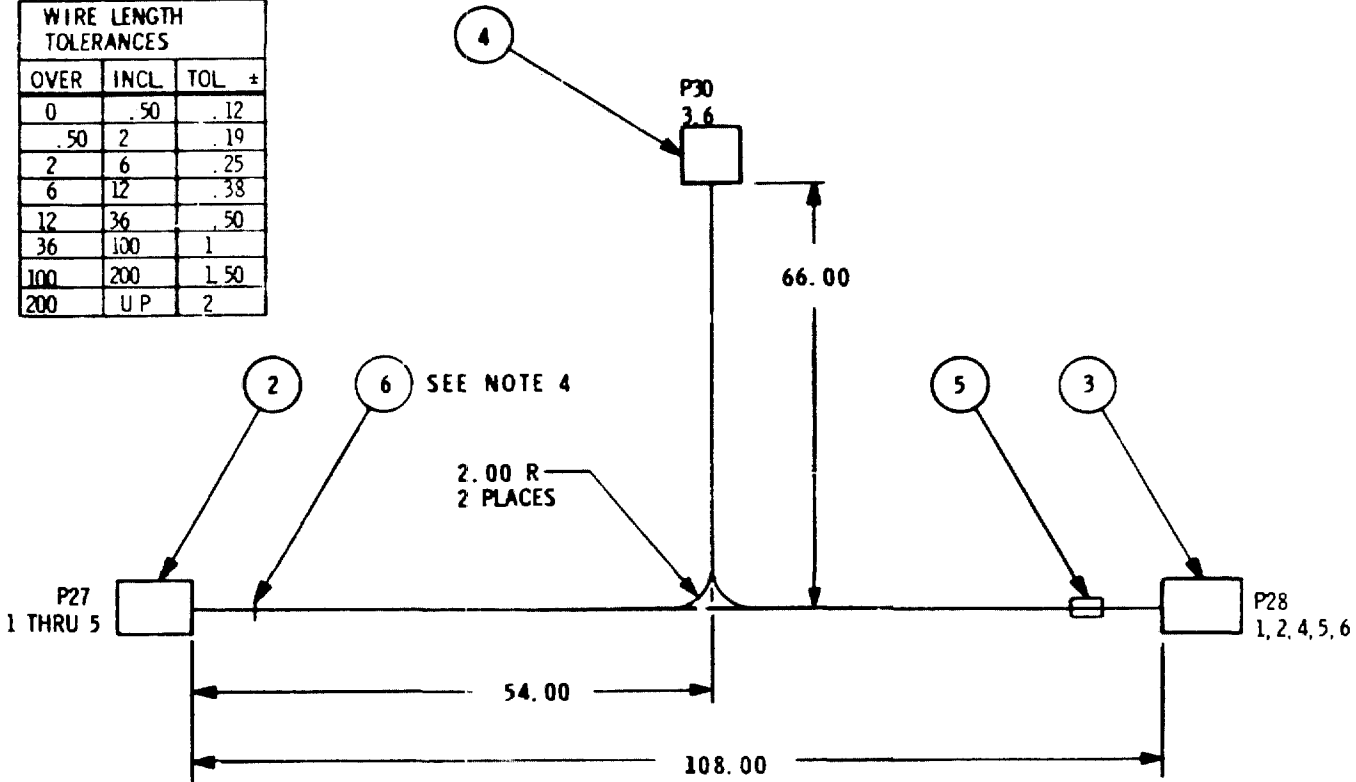

WIRE NO.	WIRE MARKING IDENTIFICATION		FROM	TERMN FIND NO.	TO	TERMN FIND NO.	LG REF
	COLOR	NUMBER					
1	RED	P55S12	P27-A	2	P28-A	3	108.00
2	RED	P70A12	P27-B	2	P28-B	3	108.00
3	RED	V65A12	P27-C	2	P30-A	4	120.00
4	RED	P82A12	P27-D	2	P28-D	3	108.00
5	RED	P83A12	P27-E	2	P28-E	3	108.00
6	RED	V64A12	P30-B	4	P28-C	3	120.00

- NOTES:
1. INTERPRET DRAWING PER MIL-STD-100.
  2. ALL CONDUCTOR ENDS TO BE STRIPPED BACK 0.25 INCH (6.3 MM) APPROX. AND TINNED BEFORE ASSEMBLY.
  3. USE SOLDER, FIND NO. 7. SOLDER CONNECTIONS PER MIL-STD-454, REQ 5.
  4. CABLE STRAPS, FIND NO. 6 SHALL BE SPACED AT APPROX. 3.00 INCHES (76.2 MM) APART UNLESS OTHERWISE SPECIFIED.
  5. WIRE MARKING TO BE IN ACCORDANCE WITH MIL-W-5088. EXCEPT THAT INTERVALS SHALL NOT EXCEED 6.00 INCHES (152 MM).
  6. PART NO. MARKING TO BE METAL STAMPED IN ACCORDANCE WITH MIL-STD-130.

7			SN60WRAP2	AR	SOLDER, LEAD TIN ALLOY, ROSIN CORE QQ-S-571		NOTE 3
8			MS3367-1-9	52	STRAP, TIEDOWN		NYLON
6			MS39020-2	1	BAND, MARKER		AL ALY
4			MS3106R16-10S	1	CONNECTOR, PLUG		
3			MS3106R18-11S	1	CONNECTOR, PLUG		
2			MS3106R18-11S	1	CONNECTOR, PLUG		
1			M5088/2-12-9	AR	WIRE, ELECTRICAL	MIL-W-50C7/2	
FIND NO.	CODE IDENT	DWG SIZE	PART NO. IDENTIFYING NO.	QTY REQD	NOMENCLATURE OR DESCRIPTION	SPECIFICATION	MATERIAL

Figure 5-5. Heater Control Box to Fuel Burning Heater, Wiring Harness

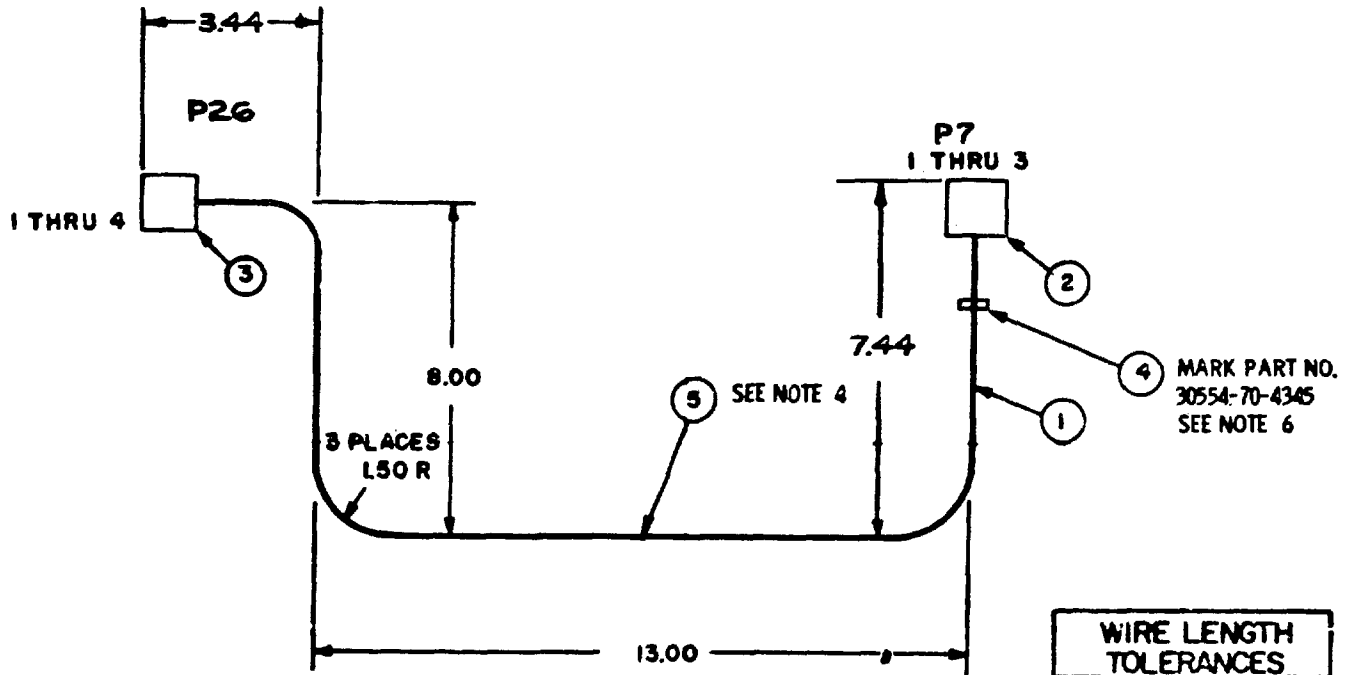

WIRE NO.	WIRE MARKING IDENTIFICATION		FROM	TERMN FIND NO.	TO	TERMN FIND NO.	LG REF
	COLOR	NUMBER					
1	RED	P55RR12	P7-A	2	P26-A	3	30.00
2	RED	P51B12	P7-B	2	P26-B	3	30.00
3	RED	P141E12	P7-E	2	P26-E	3	30.00
4	—	JUMPER	P26-C	3	P26-D	3	3.00

WIRE LENGTH TOLERANCES		
OVER	INCL	TOL ±
0	.50	.12
.50	2	.19
2	6	.25
6	12	.38
12	36	.50
36	100	1
100	200	1.50
200	UP	2

NOTES:

1. INTERPRET DRAWING PER MIL-STD-100.
2. ALL CONDUCTOR ENDS TO BE STRIPPED BACK 0.25 INCH (6.3 MM) AND TINNED BEFORE ASSEMBLY.
3. USE SOLDER, FIND NO. 6. SOLDER CONNECTIONS PER MIL-STD-454. REQT 5.
4. CABLE STRAPS, FIND NO. 5. SHALL BE SPACED APPROX. 3.00 INCHES (76.2 MM) APART UNLESS OTHERWISE SPECIFIED.
5. WIRE MARKING TO BE IN ACCORDANCE WITH MIL-W-5088 EXCEPT THAT INTERVALS SHALL NOT EXCEED 6.00 INCHES (152 MM).
6. PART NO. MARKING TO BE METAL STAMPED IN ACCORDANCE WITH MIL-STD-130.

6			SN60WRAP2	AR	SOLDER, LEAD-TIN ALLOY, ROSIN CORE	QQ-S-571	NOTE 3
5			MS3367-1-9	9	STRAP, TIEDOWN		
4			MS39020-1	1	BAND, MARKER		AL ALY
3			MS3106R18-11S	1	CONNECTOR, PLUG		
2			MS3106R18-11P	1	CONNECTOR, PLUG		
1			MS086/2-12-9	AR	WIRE, ELECTRICAL	MIL-W-5086/2	
PNB NO	CODE IDENT	QWSG SIZE	PART OR IDENTIFYING NO	QTY REQD	NOMENCLATURE OR DESCRIPTION	SPECIFICATION	MATERIAL

LIST OF MATERIAL

Figure 5-6. Special Relay Box to Fuel Burning Heater Control Box, Wiring Harness

assembly. Apply thread sealing compound, MIL-S-45180, Type III to coupling threads of replacement hoses and threads of any elbows, connectors, and fittings which are also being replaced.

(4) Close valve (33). Open valves (15 and 28).

(5) Service radiator (refer to paragraph 3-14b).

b. Rebuild.

(1) Drain the radiator (refer to paragraph 3-14c).

(2) Refer to figure 5-1 and remove all hoses, lines, and fittings.

NOTE

Apply thread sealing compound conforming to MIL-S-45180, Type III to all pipe threads prior to installation of elbows, bushings, and pipe connectors.

(3) Replace all hoses, lines, and fittings (refer to paragraph 5-2).

(4) Service radiator with arctic antifreeze compound conforming to MIL-A-1175 (refer to paragraph 3-14b).

5-18. CONTROL BOX ASSEMBLY. The following paragraphs provide inspection, test, installation, and replacement procedures for the control box assembly (8, figure 5-1).

a. Inspect. Inspect the control box assembly for secure mounting, and check security of electrical connectors.

b. Test.

(1) Remove electrical connectors.

(2) Refer to figure 1-6 and check control box for continuity with switch and circuit breaker in each functional position. Replace control box if defective.

(3) Install electrical connectors on control box.

c. Install. Refer to figure 5-1 and paragraph 5-2.

d. Replace. Refer to figure 5-1 and proceed as follows:

(1) Disconnect plugs P26 and P27 from the rear of control box (8).

(2) Remove screws and washers which secure control box.

(3) Replace box using screws and washers.

(4) Connect plugs P26 and P27 to rear of control box.

5-19. LIGHT ASSEMBLY. The following paragraphs provide inspection and test procedures for the light assembly (see figure 5-7).

a. Inspect. Inspect lens (8) for cracks or damage, and indicator light (12) for security of attachment and loose connections.

b. Test. Test the light assembly by energizing the circuit breaker and pressing the PRESS-TO-TEST INDICATOR (see figure 2-12).

5-20. LAMP. Replace the control box lamp as illustrated in figure 5-8.

5-21. CIRCUIT BREAKER. Inspect the circuit breaker in the heater control box (see figure 5-7) as follows:

a. Remove two screws (1) from plate (13).

b. Remove nut (2), washer (3), and tab washer (4) from switch (5).

c. Remove nut (6) from circuit breaker (7).

d. Remove lens (8), nut (9), and washer (10) from indicator light (12).

e. Remove plate (13) and inspect circuit breaker (7) for obvious damage, overheating, carbon deposits, and loose electrical connections.

f. Replace plate (13), screws (1), washer (10), nut (9), lens (8), nut (6), tab washer (4), washer (3) and nut (2).

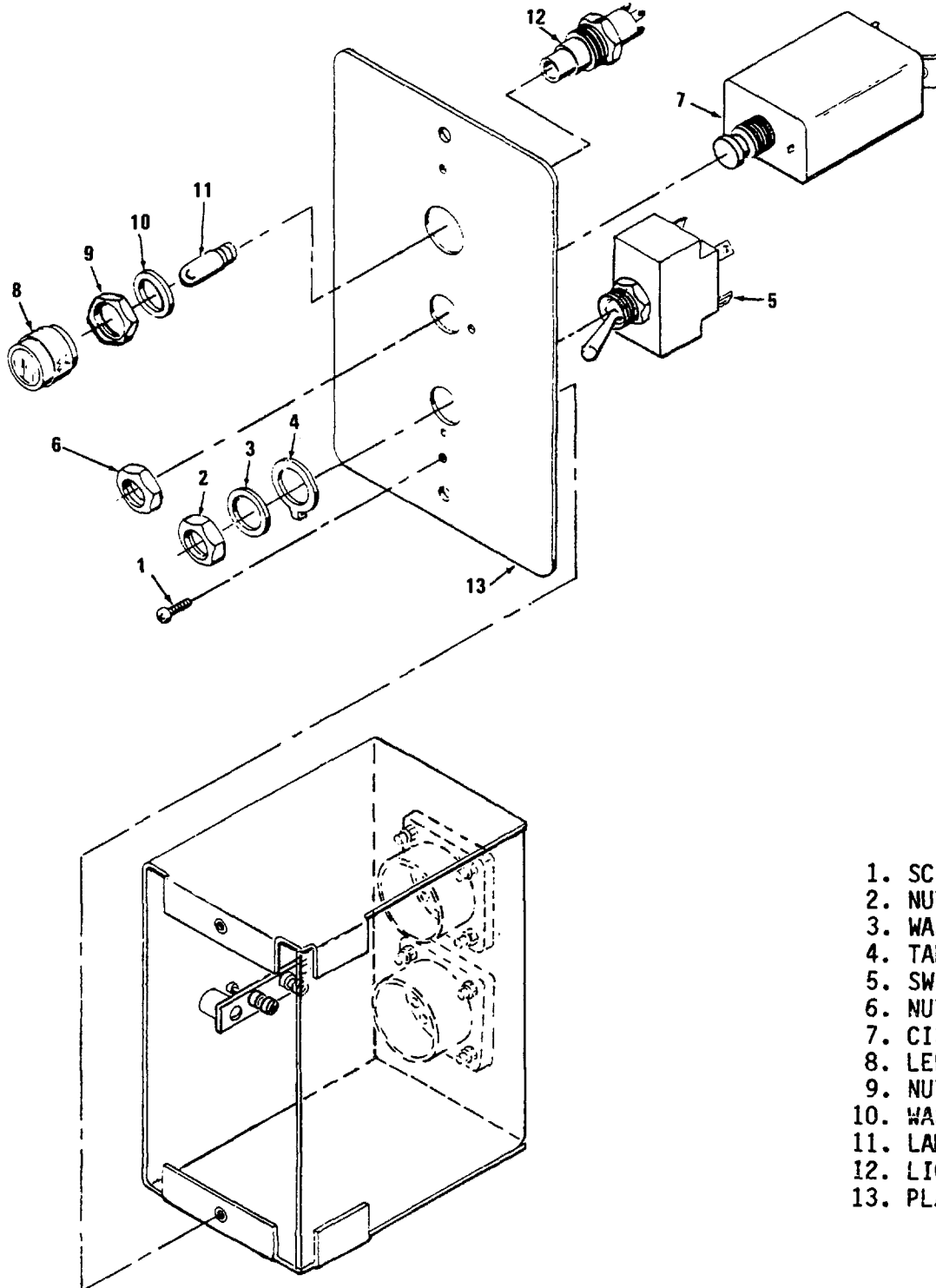

- 1. SCREW
- 2. NUT
- 3. WASHER
- 4. TAB WASHER
- 5. SWITCH
- 6. NUT
- 7. CIRCUIT BREAKER
- 8. LENS
- 9. NUT
- 10. WASHER
- 11. LAMP
- 12. LIGHT
- 13. PLATE

Figure 5-7. Fuel Burning Winterization Kit Control Box Assembly, Partially Exploded View

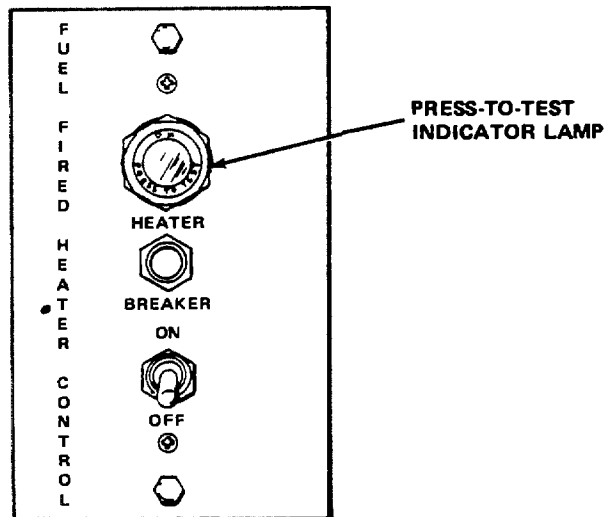

- STEP 1. UNSCREW PRESS-TO-TEST INDICATOR LIGHT LENS AND REMOVE LAMP BY PRESSING IN AND TURNING COUNTERCLOCKWISE.
- STEP 2. INSTALL NEW LAMP AND LENS.
- STEP 3. ENERGIZE CIRCUIT BREAKER BY PRESSING IN ON BREAKER BUTTON AND PRESS-TO-TEST INDICATOR LIGHT. INDICATOR SHOULD ILLUMINATE WHEN PRESSED. DEENERGIZE CIRCUIT BREAKER.

Figure 5-8. Fuel Burning Winterization Kit Control Box, Lamp Replacement



## Section II. ELECTRIC WINTERIZATION KIT

5-22. GENERAL. The electric winterization kit preheats engine coolant and lubricating oil for ease of generator set starting in ambient temperatures down to  $-65^{\circ}\text{F}$  ( $-53.9^{\circ}\text{C}$ ). The kit is integrally mounted in the generator set and consists of an electric coolant heater, control box, coolant pump, thermostat, coolant and drain valves, wiring, lines, and fittings. Heated coolant is circulated through the engine cooling system and oil pan heat exchanger by the coolant pump. Automatic heater cycling is controlled by the thermostat to prevent excessive coolant temperature. The heater, coolant pump, and thermostat are located in the left engine compartment. Power for kit operation may be obtained from any power source that supplies 205 to 240 volts, 50 or 60 Hertz, single-phase power.

5-23. INSTALLATION. To perform initial installation of the electric winterization kit, proceed as follows:

### WARNING

Disconnect negative cable of either battery.

- a. Disconnect plate (3, figure 2-1) by removing four screws (62, figure 5-9) and four washers (61). Retain screws and washers for installing kit control box.
- b. Drain radiator (refer to paragraph 3-14c).
- c. Remove plugs from engine and install elbow (59, figure 5-9).
- d. Remove two plugs from engine oil pan heat exchanger (62) and install two connectors (58).

### NOTE

Apply thread sealing compound conforming to MIL-S-45180, Type III to all pipe threads prior to installation of elbows, bushings, and pipe connectors.

e. Install control box (57) to control cubicle using four screws (61) and four washers (60) previously removed.

f. Install connector P1 of harness assembly (56) to upper receptacle on control box, then install clamp (55) using screw (54) and nut (53).

g. Install tee (52), connector (51), coolant valve (50), connector (49), hose assembly (48), coolant drain valve (47), elbow (46), tee (45), elbow (44), and hose assembly (43).

h. Install electric heater (42) using bracket (41), seven washers (40), and seven screws (39).

i. Install tee (38), plug (37), connector (36), reducer (35), elbow (34), and hose assembly (33).

j. Remove two screws (29) and heater cover (30), then slide harness wire (terminal lugs 3 and 4) through cover and secure with two washers (32) and two nuts (31). Reinstall heater cover (30) using two screws (29).

k. Install nipple (28) and thermostat (27).

l. Remove screw (26) and cover (25) from thermostat, then slide harness wire (terminal lugs 5 and 6) through grommet (24) and cover (25). Secure leads to thermostat using two washers (23) and two screws (22), then secure cover (25) to thermostat using screw (26).



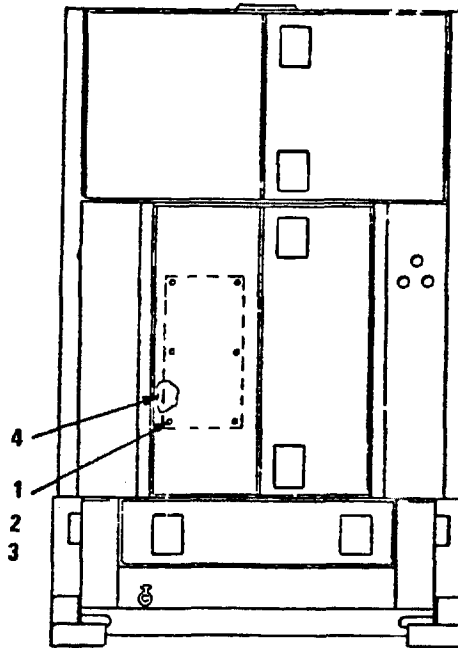

REAR VIEW OF GENERATOR SET

- |                      |                |                    |
|----------------------|----------------|--------------------|
| 1. NUT               | 23. WASHER     | 45. TEE            |
| 2. WASHER            | 24. GROMMET    | 46. ELBOW          |
| 3. SCREW             | 25. COVER      | 47. DRAIN VALVE    |
| 4. INSTRUCTION PLATE | 26. SCREW      | 48. HOSE ASSY      |
| 5. HOSE ASSY         | 27. THERMOSTAT | 49. CONNECTOR      |
| 6. CONNECTOR         | 28. NIPPLE     | 50. COOLANT VALVE  |
| 7. PLUG              | 29. SCREW      | 51. CONNECTOR      |
| 8. TEE               | 30. COVER      | 52. TEE            |
| 9. NIPPLE            | 31. NUT        | 53. NUT            |
| 10. COOLANT VALVE    | 32. WASHER     | 54. SCREW          |
| 11. ELBOW            | 33. HOSE ASSY  | 55. CLAMP          |
| 12. HOSE ASSY        | 34. ELBOW      | 56. HARNESS ASSY   |
| 13. ELBOW            | 35. REDUCER    | 57. CONTROL BOX    |
| 14. SCREW            | 36. CONNECTOR  | 58. CONNECTOR      |
| 15. LOCKWASHER       | 37. PLUG       | 59. ELBOW          |
| 16. WASHER           | 38. TEE        | 60. WASHER         |
| 17. CLAMP            | 39. SCREW      | 61. SCREW          |
| 18. BRACKET          | 40. WASHER     | 62. HEAT EXCHANGER |
| 19. COOLANT PUMP     | 41. BRACKET    |                    |
| 20. ELBOW            | 42. HEATER     |                    |
| 21. REDUCER          | 43. HOSE ASSY  |                    |
| 22. SCREW            | 44. ELBOW      |                    |

Figure 5-9. Electric Winterization Kit,  
 Removal and Installation (Sheet 2 of 2)

m. Install reducer (21), elbow (20), and coolant pump (19), using bracket (18), clamp (17), two washers (16), two lockwashers (15), and two screws (14).

n. Install elbow (13) and hose assembly (12).

o. Install elbow (11), coolant valve (10), nipple (9), tee (8), plug (7), connector (6), and hose assembly (5).

p. Attach harness lead with connector to connector on coolant pump (19) and secure wire (terminal lug 2) to coolant pump (19).

#### WARNING

Drilling operations create metal chips that may enter the eye. Wearing of goggles is required.

q. Use instruction plate (4) as a template and drill six 0.156-inch (3.96 mm) diameter holes as shown in figure 5-9 and install instruction plate (4) to rear generator set door using six screws (3), six washers (2), and six nuts (1).

r. Remove protective cover from box (57). Connect a suitable power cable to control box receptacle J49 and a 205 to 240 volts, 50/60 Hertz single phase power supply.

s. Service radiator with arctic antifreeze compound conforming to Military Specification MIL-A-11755 (refer to paragraph 3-14b).

t. Connect battery cable.

5-24. LUBRICATION. No lubrication of the electric winterization kit is required.

#### 5-25. PREVENTIVE MAINTENANCE CHECKS AND SERVICES.

a. General. To ensure that the electric winterization kit is ready for operation at all times, it must be inspected systematically so defects may be discovered and corrected before they result in serious damage or failure. The necessary preventive

maintenance checks and services that are to be performed by operator personnel are: inspection of the coolant valves and the wiring harness, checking radiator coolant level, and inspection of generator set doors for proper sealing. Preventive maintenance checks and services to be performed by organizational maintenance are: replacement of leaking valves and coolant lines, tightening of clamps and attaching hardware, inspection of wiring harness terminal lugs and connectors for security, and testing the thermostat switch and heater. Defects discovered during operation will be noted for future correction. Stop operation immediately if a deficiency is noted which would damage the equipment. All deficiencies and short-comings will be recorded together with the corrective actions taken on the applicable form. Air Force users shall refer to the applicable inspection manuals and work card sets in TO 35C2-3 for periodic requirements and Tables 5-5 and 5-6 for detailed procedures.

b. (A,N, MC) Preventive Maintenance Checks and Services. Table 5-5 contains a tabulated listing of the PMCS which shall be performed by operator personnel. Table 5-6 contains a tabulated listing of the PMCS which shall be performed by organizational personnel. The item numbers in each table are listed consecutively and indicate the sequence of minimum requirements.

#### 5-26. TROUBLESHOOTING.

a. This section contains troubleshooting information for locating and correcting operating troubles which may develop in the generator set. Table 5-7 is applicable to the operator. Table 5-8 contains organizational troubleshooting procedures. Each malfunction for an individual component unit, or system is followed by a list of tests or inspections which will help you to determine

probable causes and corrective actions to take. Perform the tests/inspections and corrective actions in the order listed.

b. This manual cannot list all malfunctions that may occur, nor all tests or inspections and corrective actions. If a malfunction is not

listed or cannot be corrected by listed corrective actions, notify your supervisor.

NOTE

Before you use table 5-7, be sure you have performed all applicable operating checks.

Table 5-5. Electric Winterization Kit, Operator/Crew Preventive Maintenance Checks and Services

INTERVAL			B - BEFORE OPERATION D - DURING OPERATION A - AFTER OPERATION DAILY - 8HRS	TOTAL T/H: 0.6
OPERATOR			ITEMS TO BE INSPECTED INSPECTION PROCEDURES	WORK TIME T/H
DAILY				
B	D	A		
1			COOLANT LINES AND VALVES Check for leaks, damage and deformation (refer to figure 5-9).	0.2
2			GENERATOR SET RADIATOR Check for proper coolant level (refer to paragraph 3-14b).	0.1
3			GENERATOR SET DOORS Check doors for proper sealing.	0.1
	4		COOLANT LINES AND VALVES Check for leakage during operation (refer to figure 5-9).	0.1

Table 5-6. Electric Winterization Kit, Organizational Preventive Maintenance Checks and Services

INTERVAL			W - WEEKLY (40 HRS)	M - MONTHLY (100 HRS)	S - SEMI-ANNUALLY (500 HRS)	TOTAL T/H:
						0.0
						0.0
						0.9
ORGANIZATION			ITEMS TO BE INSPECTED INSPECTION PROCEDURES			WORK TIME T/H
W	M	S				
		1	COOLANT LINES AND VALVES Check for leakage. Replace leaking or frayed lines (refer to figure 5-9).			0.3
		2	CLAMPS AND ATTACHING HARDWARE Tighten all hardware and clamps (refer to figure 5-9).			0.2
		3	WIRING HARNESS Inspect for frayed insulation and security of terminal lugs and connectors (refer to figure 5-9).			0.1
		4	THERMOSTAT Test for proper operation (refer to paragraph 5-32b).			0.2
		5	HEATER Test element (refer to paragraph 5-31b).			0.2

Table 5-7. Electric Winterization Kit, Operator/Crew Troubleshooting

---

MALFUNCTION	TEST OR INSPECTION	CORRECTIVE ACTION
-------------	--------------------	-------------------

---

1. ELECTRIC HEATER ON-OFF SWITCH POSITIONED TO ON AND NOTHING HAPPENS.
  - Step 1. Check that power cable is connected to power supply.

Connect power cable (see figure 5-9).
  - Step 2. Inspect electric winterization kit wiring harness for frayed insulation and loose terminals.

Refer to next higher level of maintenance for replacement or repair.
2. INDICATOR LIGHT DOES NOT LIGHT.
  - Step 1. Test indicating lamp (refer to paragraph 5-27b).

Refer to next higher level of maintenance for replacement.
  - Step 2. Inspect electric winterization kit wiring harness for frayed insulation and loose terminals (refer to figure 5-9).

Refer to next higher level of maintenance for replacement or repair.
3. HEATER CYCLING ERRATIC.

Inspect electric winterization kit wiring harness for frayed insulation and loose terminals.

Refer to next higher level of maintenance for replacement or repair.
4. HEATED COOLANT IS NOT CIRCULATED THROUGH COOLING SYSTEM.
  - Step 1. Check that coolant valves (19 and 50, figure 5-9) are open.

Open valves.

---

Table 5-8. Electric Winterization Kit,  
Organizational Troubleshooting

---

MALFUNCTION
TEST OR INSPECTION
CORRECTIVE ACTION

---

1. ELECTRIC HEATER ON-OFF SWITCH POSITIONED TO ON AND NOTHING HAPPENS.

Step 1. Test fuse (refer to paragraph 5-35b).

Replace defective fuse (refer to paragraph 5-35e).

Step 2. Inspect power switch (refer to paragraph 5-35a).

Refer to next higher level of maintenance for replacement of defective power switch.

Step 3. Inspect and test thermostat switch (refer to paragraph 5-32).

Replace defective thermostat (refer to paragraph 5-32c).

Step 4. Inspect and test control box wiring harness (refer to paragraph 5-35).

Replace or repair defective wiring harness (refer to paragraph 5-35).

2. INDICATOR LIGHT DOES NOT LIGHT.

Step 1. Inspect and test light assembly (refer to paragraph 5-35).

Refer to next higher level of maintenance for replacement of defective light assembly.

Step 2. Inspect and test heating element (refer to paragraph 5-31).

Replace defective heating element (refer to paragraph 5-31c).

Step 3. Inspect and test control box wiring harness (refer to paragraph 5-35).

Replace or repair defective wiring harness (refer to paragraph 5-35).



Table 5-8. Electric Winterization Kit,  
Organizational Troubleshooting (Continued)

MALFUNCTION	TEST OR INSPECTION	CORRECTIVE ACTION
3. HEATER CYCLING IS ERRATIC.	Step 1. Inspect and test thermostat switch (refer to paragraph 5-32).	Replace defective thermostat (refer to paragraph 5-32c).
	Step 2. Inspect coolant pump motor (refer to paragraph 5-30a).	Repair defective motor (refer to paragraph 5-30b).
	Step 3. Inspect and test heating element (refer to paragraph 5-31).	
4. HEATED COOLANT IS NOT CIRCULATED THROUGH COOLING SYSTEM.	Inspect coolant pump motor (refer to paragraph 5-30a).	Repair defective motor (refer to paragraph 5-30b).

5-27. OPERATOR/CREW MAINTENANCE PROCEDURES. The following maintenance procedures are to be performed by Operator/Crew personnel.

a. Inspect. Visually inspect hoses and fittings for fraying or cracks. Ensure that all hoses and fittings are secure, and that there are no signs of leakage or restrictions when the system is operating (refer to figure 5-9). Inspect the wiring harness (56) for loose connections and frayed insulation.

b. Test. Test the indicating lamp as follows:

(1) Refer to figure 2-14 and set the ELECTRIC HEATER CONTROL SWITCH to ON.  
(2) Indicating lamp should light.

(3) If lamp does not light, refer to next higher maintenance for replacement.

5-28. ORGANIZATIONAL MAINTENANCE PROCEDURES. The maintenance procedures of paragraphs 5-29 through 5-35 are to be performed by the organizational level of maintenance.

5-29. ELECTRIC WINTERIZATION KIT.

a. Test. Refer to paragraph 2-9 and operate the electric winterization kit to determine if the electric heater is operational.

b. Install. Refer to paragraph 5-23 for installation procedures.

c. Replace.  
(1) Drain radiator (refer to paragraph 3-14c).  
(2) Refer to figure 5-9 and remove hoses, fittings, connectors, electric heater, etc.

NOTE

Apply thread sealing compound conforming to MIL-S-45180, Type

III to all pipe threads prior to installation of elbows, bushings, and pipe connectors.

(3) Refer to paragraph 5-23, as applicable, and install a new electric winterization kit.

(4) Service radiator with arctic antifreeze compound conforming to Military Specification MIL-A-11755 (refer to paragraph 3-14b).

5-30. COOLANT PUMP AND MOTOR. The following paragraphs provide inspection and repair procedures for the coolant pump and motor assembly (19, figure 5-9).

a. Inspect.

(1) Refer to figure 5-9 and inspect the coolant pump and motor assembly for overheating, leaks, loose connections, and loose mounting.

(2) Refer to figure 5-10. Remove brushcaps (1) and check motor brush and springs (2) for damage or excessive wear. Brushes should be at least 1/4 inch (635 mm) long.

(3) Inspect connector (3) for bent pins.

b. Repair. Repair of the coolant pump and motor assembly consists of replacing the brush and spring (refer to figure 5-10). Replace brushes which are less than 1/4-inch (635 mm) long.

5-31. HEATING ELEMENT. The following paragraphs provide inspection, test, and replacement procedures for the heating element of the electric heater (42, figure 5-9).

a. Inspect.

(1) Refer to paragraph 5-31c, below, and remove the heating element.

(2) Inspect heating element (3, figure 5-11) for breaks and damage.

(3) Replace heating element in accordance with paragraph 5-31c.

b. Test.

WARNING

Make sure kit power cable is removed from power supply.

(1) Disconnect heater cover (30, figure 5-9) by removing screws (29).

(2) Tag and disconnect harness wires from heater terminal studs by removing two nuts (31) and two washers (32).

(3) Connect a single-phase, 205 to 240 volt, 50/60 Hertz power supply to heater. Connect a suitable ammeter and wattmeter in series with the heater and power supply.

(4) Apply 230 vac and observe wattmeter and ammeter. Heater should draw 10.8 amperes and 2500 watts.

(5) Remove test equipment from heater. If heater does not meet specification in step (4), replace heater in accordance with paragraph 5-31c.

(6) Remove tags and connect harness wires to heater terminal studs using two nuts (31) and two washers (32).

(7) Position heater cover (30) on heater and secure with screws (29).

c. Replace.

(1) Disconnect heater cover (30, figure 5-9) by removing screws (29).

(2) Tag and disconnect harness wires from heater terminal studs by removing nuts (31) and washers (32).

(3) Remove end cap (2, figure 5-11) and heater element (3).

(4) Install new heater element (3) and reinstall end cap (2).

(5) Remove tags and connect harness wires to heater terminal studs using two nuts (31, figure 5-9) and two washers (32).

(6) Position heater cover (30) on heater and secure with screws (29).

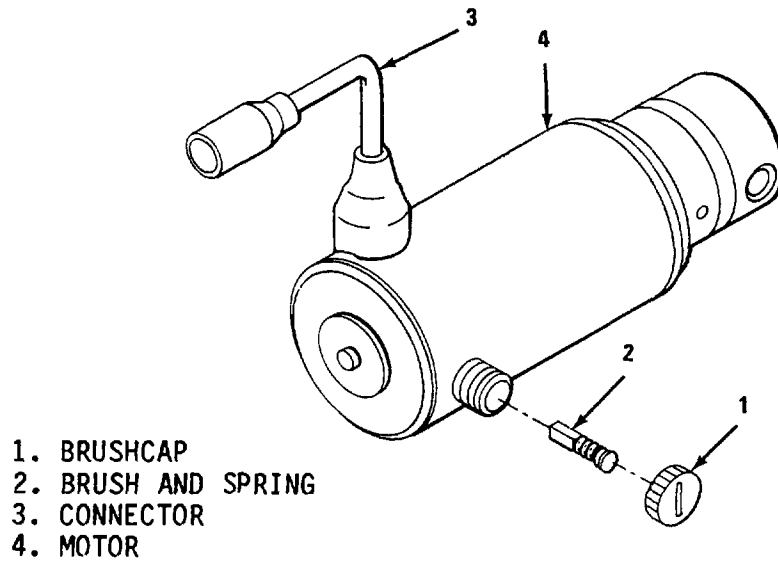

Figure 5-10. Coolant Pump and Motor Assembly

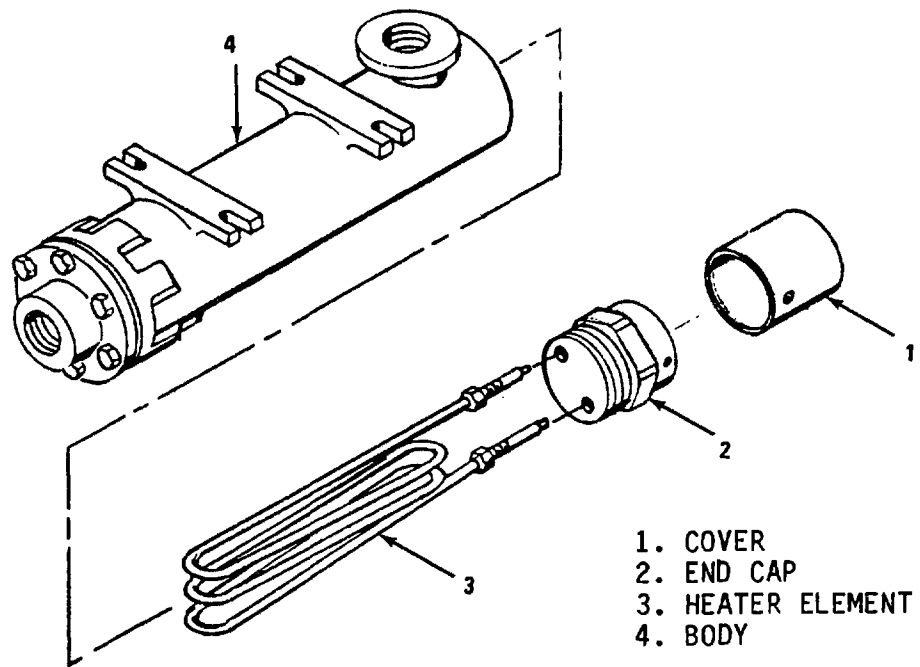

Figure 5-11. Electric Heater, Exploded View

5-32. THERMOSTAT SWITCH. The following paragraphs provide inspection, test, and replacement procedures for the thermostat switch (27, figure 5-9).

a. Inspect.

(1) Inspect the thermostat switch for corrosion and loose mounting.

(2) Remove screws (26) and cover (25). Check leads for secure attachment.

(3) Reinstall cover (25) using screws (26).

b. Test.

(1) Disconnect power cable from power supply.

(2) Remove thermostat switch as explained in paragraph 5-32c, below.

(3) Fill a container with water and place a thermometer in the container. Place temperature sensing end of thermostat in water.

(4) Heat water and check thermostat switch for continuity. There should be continuity between terminals up to 120°F (48.8°C) and no continuity at temperatures above 120°F (48.8°C).

(5) Permit water to cool. Contacts should close and indicate continuity at 100°F (37.7°C).

(6) Remove test equipment. Install a new thermostat switch, if defective (refer to paragraph 5-32c, below).

(7) Connect power cable to power supply.

c. Replace.

(1) Disconnect power cable from power supply.

(2) Place a container under tee (45, figure 5-9). Close valves (10 and 50). Open drain valve (47).

(3) Remove cover (25) by removing screws (26).

(4) Tag and disconnect electrical leads by removing two screws (22) and two washers (23).

(5) Remove reducer (21) from thermostat switch (27), then remove thermostat switch from nipple (28).

(6) Install new thermostat switch (27) between nipple (28) and reducer (21).

NOTE

Apply thread sealing compound conforming to MIL-S-45180, Type III to all pipe threads prior to installation of thermostat switch.

(7) Open coolant valves (10 and 50). Close valve (47).

(8) Service radiator (refer to paragraph 3-14b).

(9) Connect power cable to power supply.

5-33. HOSES AND FITTINGS.

a. Close valves (10 and 50, figure 5-9). Place a container under tee (45), then open valve (47).

b. Replace hose assemblies (5, 12, 33, 43, and 48) by unscrewing coupling at each end of hose assembly. Apply thread sealing compound, MIL-S-45180, Type III to coupling threads of replacement hoses and threads of any elbows, connectors, and fittings which are also being replaced.

c. Close valve (47). Open valves (10 and 50).

d. Service radiator (refer to paragraph 3-14b).

5-34. WIRING HARNESS. The following paragraphs provide test, replacement, and repair procedures for the wiring harness (56, figure 5-9).

a. Test. Perform continuity check using an ohmmeter between connecting points in the harness (refer to figure 5-12). Check for short circuits between pins of the connector plug.

b. Replace.

(1) Remove connector plug P1 of wiring harness (56, figure 5-9) from control box (57).

- NOTES:
1. ALL CONDUCTOR ENDS TO BE STRIPPED BACK 0.25 INCH (6.3 MM) AND TINNED BEFORE ASSEMBLY.
  2. USE SOLDER, FIND NO. 9. SOLDER CONNECTIONS PER MIL-STD-454, REQT 5.
  3. CABLE STRAPS, FIND NO. 8, SHALL BE SPACED AT APPROX. 3.00 INCHES (76.2 MM) APART UNLESS OTHERWISE SPECIFIED.
  4. WIRE MARKING TO BE IN ACCORDANCE WITH MIL-W-5088. EXCEPT THAT INTERVALS SHALL NOT EXCEED 6.00 INCHES (152 MM).
  5. PART NO. MARKING TO BE METAL STAMPED IN ACCORDANCE WITH MIL-STD-130.

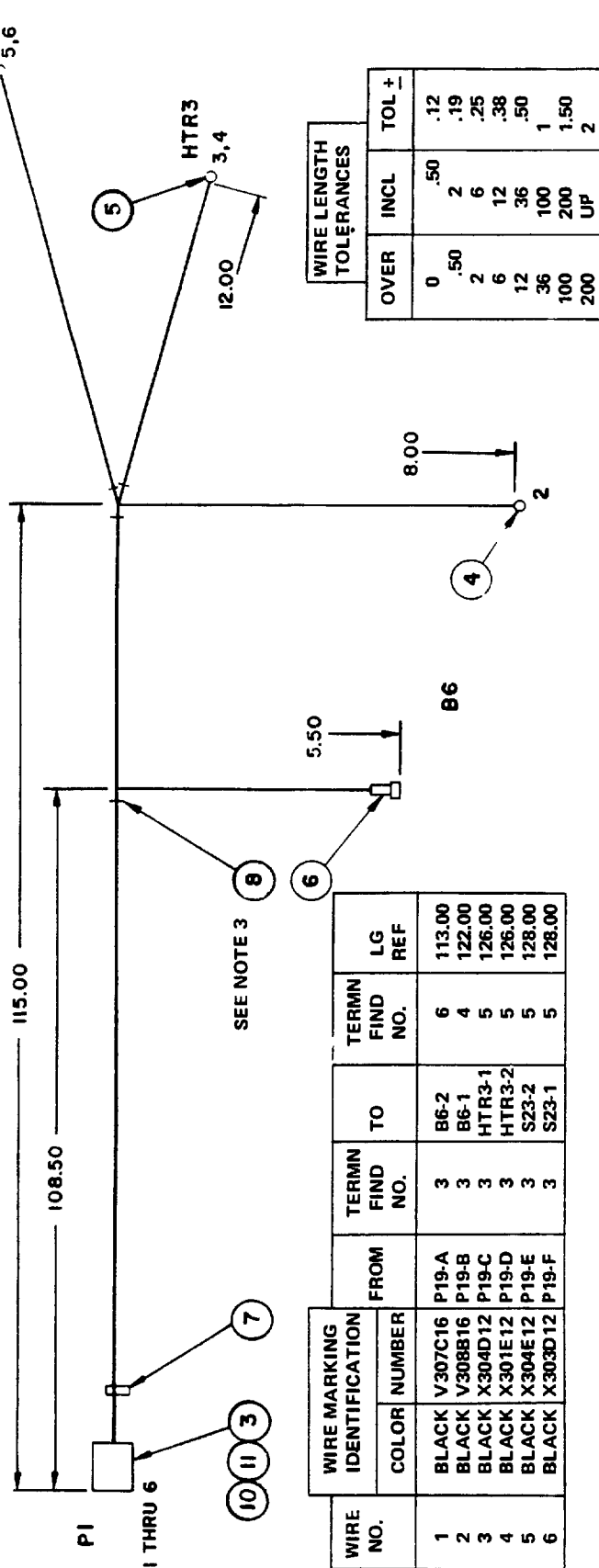

WIRE NO.	WIRE MARKING IDENTIFICATION		FROM	TERMN FIND NO.	TO	TERMN FIND NO.	LG REF
	COLOR	NUMBER					
1	BLACK	V307C16	P19-A	3	B6-2	6	113.00
2	BLACK	V308B16	P19-B	3	B6-1	4	122.00
3	BLACK	X304D12	P19-C	3	HTR3-1	5	126.00
4	BLACK	X301E12	P19-D	3	HTR3-2	5	126.00
5	BLACK	X304E12	P19-E	3	S23-2	5	128.00
6	BLACK	X303D12	P19-F	3	S23-1	5	128.00

FIND NO.	CODE IDENT	DWG SIZE	PART OR IDENTIFYING NO.	QTY REOD	NOMENCLATURE OR DESCRIPTION	SPECIFICATION	MATERIAL
11			MS25251-16	5	PLUG, END SEAL		
10			MS25251-12	1	PLUG, END SEAL		
9			SN60WRAP2	AR	SOLDER, LEAD-TIN ALLOY, ROSIN CORE		NOTE 2
8			MS3367-4-9	43	STRAP, TIEDOWN		NYLON
7			MS39020-2	1	BAND, MARKER		
6			MS27144-2	1	CONNECTOR ASSEMBLY, MALE		MIL-W-50862
5			MS25036-112	4	TERMINAL, LUG, CRIMP STYLE		MIL-W-50862
4			MS25036-106	1	TERMINAL, LUG, CRIMP STYLE		
3			MS3106R28-9P	1	CONNECTOR, PLUG		
2			M5086/2-12-9	AR	WIRE, ELECTRICAL		
1			M5086/2-16-9	AR	WIRE, ELECTRICAL		

Figure 5-12. Control Box to Electric Heater, Wiring Harness

(2) Unplug connector from connector on coolant pump (19) and remove lead (terminal 2) from coolant pump.

(3) Remove screws (29) from cover (30), then remove leads (terminals 3 and 4) from heater element terminals by removing two screws (31) and washers (32).

(4) Remove cover (25) by removing two screws (26), then remove lead (terminals 5 and 6) from thermostat switch by removing two screws (22) and two washers (23).

(5) Install new harness in accordance with paragraph 5-23, as applicable.

c. Repair. Repair wiring harness by accomplishing the most efficient repair procedure listed below.

#### WARNING

Disconnect negative battery cable.

#### CAUTION

Under no condition leave bare connection exposed.

#### NOTE

Repair procedure may be accomplished with harness installed in generator set.

(1) Disconnect and, if possible, remove defective wire. Connect new wire of same size and type to terminals from which defective wire was removed. Attach new wire to harness using tiedown straps.

(2) Remove defective portion of wire and connect wire ends with a solderless wire connector.

(3) Replace defective terminal lugs or connectors.

(4) If disconnected, connect negative battery cable.

5-35. ELECTRIC WINTERIZATION CONTROL BOX, WIRING HARNESS, POWER SWITCH, FUSE HOLDER, FUSE LIGHT ASSEMBLY, AND INDICATING LAMPS.

a. Inspect. Remove the control box (57, figure 5-9) in accordance with paragraph 5-35c, then proceed as follows:

(1) Check for obvious signs of damage to the control box exterior.

(2) Remove six screws (1, figure 5-13) and cover (2).

(3) Inspect wiring harness (27) for frayed insulation.

(4) Inspect power switch (10) and the fuse holder (16) for secure attachment and obvious signs of damage.

(5) Inspect light assembly (17 through 21) for cracked lens, security of attachment, secure connection of leads, and obvious signs of damage.

(6) Install cover (2) using six screws (1).

(7) Install control box (refer to figure 5-9 and paragraph 5-23, as applicable).

b. Test. Remove the control box (57, figure 5-9) in accordance with paragraph 5-35c, then proceed as follows:

#### NOTE

Control box should be disassembled only to the extent necessary to replace a defective component.

(1) Remove six screws (1, figure 5-13) and cover (2).

(2) Test resistor (6) for proper ohmic value. Value should be 2.49K ohms, 10 watts, +/-1 percent.

(3) Test switch (10), fuse (12), and light (21) for continuity.

(4) Remove harness (27) by removing four screws (25), four nuts (26), four screws (22), and four nuts (23).

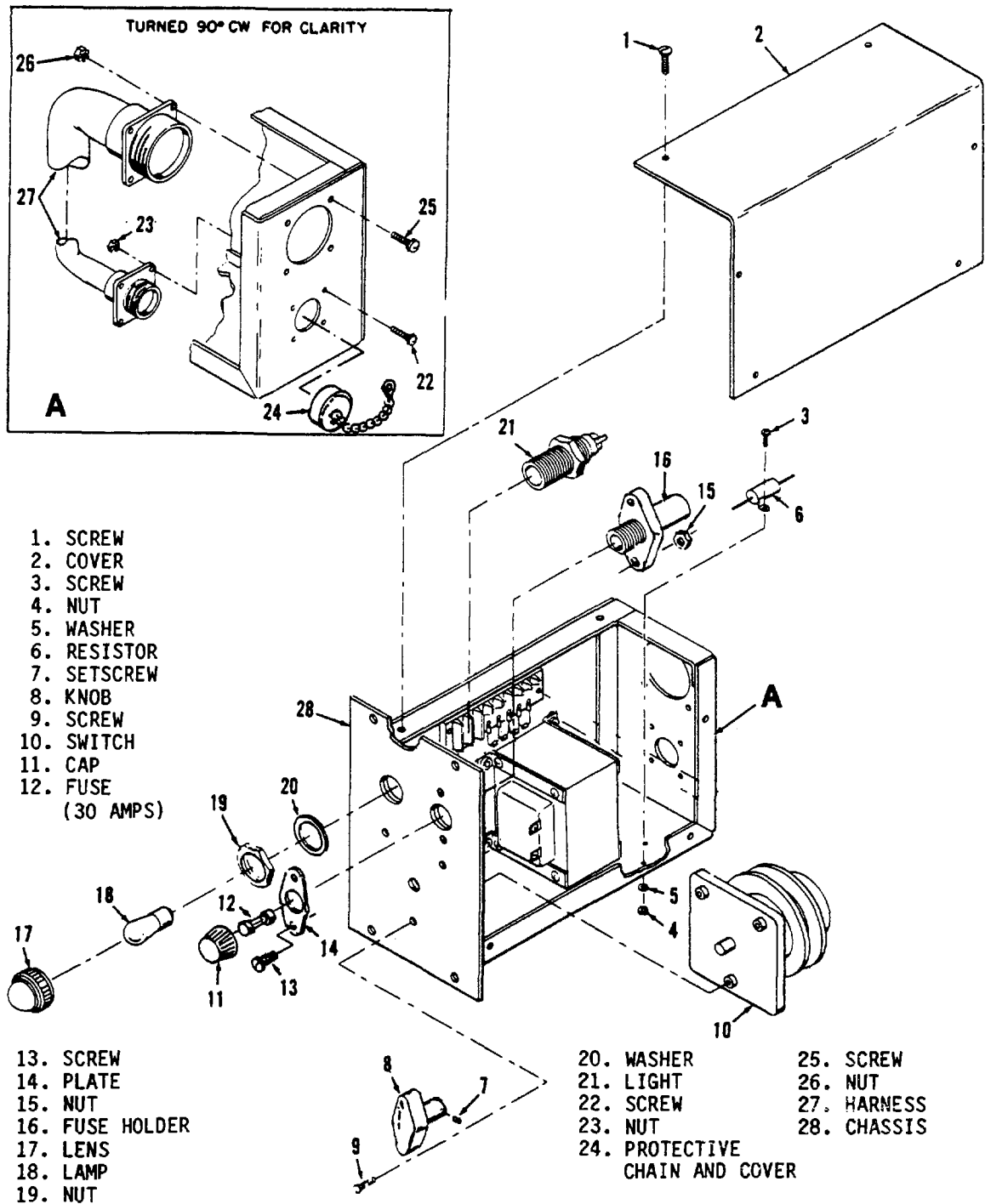

Figure 5-13. Electric Winterization Kit Control Box,  
 Partially Exploded View

(5) Perform a continuity check using an ohmmeter between connecting points in the harness.

(6) Replace harness (27) using four screws (22), four nuts (23), four screws (25), and four nuts (26).

(7) Replace defective control box components as required (refer to figure 5-13). Prior to component removal, tag and disconnect wires from defective component.

(8) Install cover (2) using six screws (1).

(9) Install control box (refer to figure 5-9 and paragraph 5-23, as applicable).

c. Install Control Box. Refer to figure 5-9 and paragraph 5-23, as applicable, for control box installation instructions.

d. Replace Control Box.

(1) Disconnect power cable from control box (57, figure 5-9).

(2) Disconnect connector P1 from control box (57).

(3) Remove four screws (62) and four washers (61).

(4) Install new control box using four screws (62) and four screws (61).

(5) Connect P1 to upper receptacle at rear of control box (57).

(6) Remove protective cover and install power cable to lower receptacle on control box (57).

e. Replace Fuse. Replace fuse (12, figure 5-13) by unscrewing cap (11), then slide out the old fuse, install a new fuse, and install cap (11).

f. Replace Indicating Lamp. Replace the indicating lamp (18, figure 5-13) as follows:

(1) Remove lens (17).

(2) Remove lamp (18).

(3) Install new lamp (18).

(4) Install lens (17).

g. Repair Wiring Harness.

Repair the control box wiring harness (27, figure 5-13) in the same manner as the electric winterization kit wiring harness (refer to paragraph 5-34c).



## APPENDIX A REFERENCES

- A-1. FIRE PROTECTION.  
TB 5-4200-200-10 Hand Portable Fire Extinguisher Approved for Army Users
- A-2. LUBRICATION  
C91001L Fuels, Lubricants, Oils and Waxes  
L05-6115-457-12 End Item Lubrication Order
- A-3. PAINTING  
T.O. 35-1-3 Painting and Marking of USAF Aerospace Ground Equipment  
TM 9-213 Painting Instructions for Field Use
- A-4. RADIO SUPPRESSION  
MIL-STD-461 Radio Interference Suppression  
TM 11-483 Radio Interference Suppression
- A-5. MAINTENANCE.  
T.O. 00-25-225 Repair of External Power Cables, Aerospace Ground Equipment  
T.O. 00-25-234 General Shop Practice Requirements for the Repair, Maintenance and Test of Electronic Equipment  
T.O. 1-1-1 Cleaning of Aerospace Equipment  
T.O. 1-1A-14 Installation Practices for Aircraft Electric and Electronic Wiring  
T.O. 1-1A-15 General Maintenance Instructions for Support Equipment  
T.O. 31-1-75 General Maintenance Practices  
T.O. 35-1-11 Organization, Intermediate and Depot Level Maintenance for FSC 6115 Non-Airborne-Equipment

AIR FORCE	T.O. 35C2-3-442-11
ARMY	TM5-6115-600-12
NAVY	NAVFAC P-8-628-12
MARINE CORPS	TM-07464B-12

T.O. 35-1-12	Compounds and Procedures for Cleaning Aerospace Ground Equipment
T.O. 35-1-26	Repair/Replacement Criteria for FSC 6115 Aerospace Ground Equipment
T.O. 35-1-524	USAF Equipment Registration Number System Applicable to FSC 6115 Equipment
TM 9-1870-1	Care and Maintenance of Pneumatic Tires
TB ORD 651	Use of Antifreeze Solutions and Cleaning Compounds in Engine Cooling Systems
TM 38-750	The Army Maintenance Management System
TM 5-6115-457-12	Operator and Organizational Maintenance Manual
TM 5-6115-457-35	Intermediate (Field) (Direct and General Support) and Depot Maintenance Manual
TM 5-6115-457-25P	Organizational, Intermediate (Field) (Direct Support and General Support) and Depot Maintenance Repair Parts and Special Tools Lists
TM 9-6140-200-15	Operation and Organizational Field and Depot Maintenance Storage Batteries, Lead Acid Type
TM 5-764	Electric Motor and Generator Repair
MIL-HDBK-705	Military Standardization Handbook, Generator Sets, Electrical Measurements and Instruments
MIL-I-6868	Inspection Process, Magnetic Particle
MIL-I-25135	Inspection Materials, Penetrant
MIL-STD-120	Gage Inspection
MIL-STD-454	Standard General Requirements for Electronic Equipment
MIL-STD-705	Generator Sets, Engine-Driven Methods of Test and Instructions
MIL-STD-1261(MR)	Welding Procedures for Construction Steels
MIL-T-27730	Tape, Antiseize, Polytetrafluoroethylene, with Dispenser
MS 33540	Safety Wiring and Cotter Pinning, General Practices for

A-6. SHIPMENT AND STORAGE

T.O. 35-1-4 Processing and Inspection of Aerospace Ground Equipment for Storage and Shipment

T.O. 38-1-5 Processing and Inspection of Non-Mounted Non-Aircraft Gasoline and Diesel Engines for Storage and Shipment

TB 740-90-1 Administrative Storage of Equipment

TB 740-93-2 Preservation of USAMEC Mechanical Equipment for Shipment and Storage

TM 38-230 Preservation, Packaging and Packing of Military Supplies of Equipment

MIL-S-207 Sulfuric Acid, Electrolyte: Packaging, Packing, and Marking for Shipment and Storage of

A-7. DESTRUCTION OF MATERIEL

TM 750-244-3 Procedures for Destruction of Equipment to Prevent Enemy Use



# APPENDIX B

## ITEMS TROOP INSTALLED OR AUTHORIZED AND MAINTENANCE AND OPERATING SUPPLIES LIST

### Section I. INTRODUCTION

B-1. SCOPE.

This appendix lists items which are authorized for use with the generator set and supplies required for operation.

B-2. GENERAL.

This list is divided into the following sections:

a. ITEMS TROOP INSTALLED OR AUTHORIZED.

SECTION II.A list of items that can be used with the generator set.

b. MAINTENANCE AND OPERATING SUPPLIES - SECTION III. A listing of maintenance of operating supplies required for initial operation.

B-3. EXPLANATION OF COLUMNS.

The following provides an explanation of columns in the tabular list of Basic Issue Items, Section II.

a. SOURCE, MAINTENANCE, AND RECOVERABILITY CODES (SMR):

(1) Source code, indicates the source for the listed item. Source codes are:

Code	Explanation
P	Repair parts which are stocked in or supplied from the GSA/DSA, or Army supply system and authorized for use as indicated maintenance categories.
P2	Repair parts which are procured and stocked for insurance purposes because the combat or military essentiality of the end item dictates that a minimum quantity be available in the supply system.
M	Repair parts which are not procured or stocked, but are to be manufactured in indicated maintenance levels.
A	Assemblies which are not procured or stocked as such, but are made of two or more units. Such component units carry individual stock numbers and descriptions, are procured and stocked separately and can be assembled to form the required assembly at indicated maintenance categories.
X	Parts and assemblies which are not procured or stocked and the mortality of which normally is below that of the applicable end item or component. The failure of such part or assembly should result in retirement of the end item from the supply system.

- X1 Repair parts which are not procured or stocked. The requirement for such items will be filled by use of the next higher assembly or component.
- X2 Repair parts which are not stocked. The indicated maintenance category requiring such repair parts will attempt to obtain them through cannibalization. Where such repair parts are not obtainable through cannibalization, requirements will be requisitioned, with accompanying justification, through normal supply channels.
- G Major assemblies that are procured with PEMA funds for initial issue only as exchange assemblies at DSU and GSU level. These assemblies will not be stocked above GS and DS level or returned to depot supply level.

(2) Maintenance code, indicates the lowest category of maintenance authorized to install the listed item. The maintenance level code is:

Code	Explanation
C	Operator/crew

(3) Recoverability code, indicates whether unserviceable items should be returned for recovery or salvage. Items not coded are expendable. Recoverability codes are:

Code	Explanation
R	Repair parts (assemblies and components) which are considered economically reparable at direct and general support maintenance levels. When the maintenance capability to repair these items does not exist, they are normally disposed of at the GS level. When supply considerations dictate, some of these repair parts may be listed for automatic return to supply for depot level repair as set forth in AR 710-50. When so listed, they will be replaced by supply on an exchange basis.
S	Repair parts and assemblies which are economically reparable at DSU and GSU activities and which normally are furnished by supply on an exchange basis. When items are determined by a GSU to be uneconomically reparable they will be evacuated to a depot for evaluation and analysis before final disposition.
T	High dollar value recoverable repair parts which are subject to special handling and are issued on an exchange basis. Such repair parts normally are repaired or overhauled at depot maintenance activities.
U	Repair parts specifically selected for salvage by reclamation units because of precious metal content, critical materials, or high dollar value reusable casings or castings.

b. NATIONAL STOCK NUMBER. This column indicates the National stock number assigned to the item and will be used for requisitioning purposes.

c. DESCRIPTION. This column indicates the Federal item name and any additional description of the item required.

The abbreviation "w/e", when used as a part of the nomenclature, indicates the Federal stock number, includes all armament, equipment, accessories, and repair parts issued with the item. A part number or other reference number is followed by applicable five-digit Federal supply code for manufacturers in parenthesis. Repair parts quantities included in kits, sets and assemblies are shown in front of the repair part name.

d. UNIT OF MEASURE (U/M). A two character alphabetic abbreviation indicating the amount or quantity of the item upon which the allowances are based, e.g., ft, ea, pr, etc.

e. QUANTITY INCORPORATED IN UNIT. This column indicates the quantity of the item used in the assembly group. A "V" appearing in this column in lieu of a quantity indicates that a definite quantity cannot be indicated (e.g., shims, spacers, etc.).

f. QUANTITY FURNISHED WITH EQUIPMENT. This column indicates the quantity of an item furnished with the equipment.

g. ILLUSTRATION. This column is divided as follows:

(1) Figure Number. Indicates the figure number of the illustration in which the item is shown.

(2) Item Number. Indicates the callout number used to reference the item in the illustration.

**B-4. EXPLANATION OF COLUMNS IN THE TABULAR LIST OF MAINTENANCE AND OPERATING SUPPLIES - SECTION III.**

a. COMPONENT APPLICATION. This column identifies the component application of each maintenance or operating supply item.

b. FEDERAL STOCK NUMBER. This column indicates the Federal stock number assigned to the item and will be used for requisitioning purposes.

c. DESCRIPTION. This column indicates the item name and brief description.

d. QUANTITY REQUIRED FOR INITIAL OPERATION. This column indicates the quantity of each maintenance or operating supply item required for initial operation of the equipment.

e. QUANTITY REQUIRED FOR 8 HOURS OPERATION. This column indicates the estimated quantities required for an average 8 hours of operation.

f. NOTES. This column indicates informative notes keyed to data appearing in a preceding column.

**B-5. SPECIAL INFORMATION.**

Identifications of the usable on codes included in column 3 of this publication are:

Code	Used on
------	---------

**B-6. ABBREVIATIONS.**

Abbreviation	Explanation
--------------	-------------

**B-7. FEDERAL SUPPLY CODE FOR MANUFACTURERS.**

Code	Manufacturer
------	--------------

**Section II. ITEMS TROOP INSTALLED OR AUTHORIZED**

(1) SMR CODE	(2) NATIONAL STOCK NUMBER	(3) DESCRIPTION	(4) (U/M)	(5) QTY INC IN UNIT	(6) QTY FURN WITH EQUIP	(7) ILLUSTRATION	
						FIGURE NO.	ITEM NO.
		Troop Installed or Authorized Items Manufacture or Depot Installed.					
PC	7510-00-894-3494	Binder Log Book	ea		1		
PC	7520-00-559-9618	Case, Maintenance and Operational Manuals, Cotton Duck Water Repellent, Mildew Resistant	ea		1		
		Lubrication Order LO 5-6115-600-12	ea		2		
		Department of The Army Operator and Organizational Maintenance Manual TM 5-6115-600-12	ea		2		
		Department of The Army Direct and General Support and Depot Maintenance Manual TM 5-6115-600-34	ea		2		
		Department of The Army Organizational Direct and General Support and Depot Maintenance Repair Parts and Special Tool List Manual TM5-6115-600-24P	ea		2		



(1) SMR CODE	(2) NATIONAL STOCK NUMBER	(3) DESCRIPTION	(4) (U/M)	(5) QTY INC IN UNIT	(6) QTY FURN WITH EQUIP	(7) ILLUSTRATION	
						FIGURE NO.	ITEM NO.
PC	5975-878-3791	Rod, Ground, Assembled	ea	1			
PC	4210-555-8837	Fire Extinguisher, Monobromotifluoromethane: 2.75 lbs w/bracket for use from 25°F and up (charged replacement cylinder ONLY NSN 4210-708-0031) GE	ea	1			
PC	4210-881-0531	Fire Extinguisher, Dry chemical, 2-1/2 lbs, w/bracket for use down to -40°F (charged replacement cylinder ONLY NSN 4210-889-2222) see NOTE: For applications are generally lower than +20°F and extinguisher NSN 4210-555-8837 is authorized, requisitions should be placed for extinguisher NSN 4210-881-0531					
PC	4720-021-3320	Hose, Auxiliary, FUEL (FMC97403) ERDL No. 13211E6770, 25 ft. 1g.	ea	1			
PC	5120-01-013-1676	Hammer, Slide	ea	1			

Section III. MAINTENANCE AND OPERATING SUPPLIES

COMPONENT APPLICATION	NATIONAL STOCK NUMBER	DESCRIPTION	QTY REQUIRED FOR INITIAL OPERATION	QTY REQUIRED 8 HOURS OPERATION	NOTES
Tank, Fuel	9130-256-8613	JP-4, MIL-J-5624 Bulk			
	9140-286-5294	FUEL OIL, DIESEL as follows: Regular Grade, DF2			
	9140-286-5286	Winter Grade, DF1			
	9140-286-5283	Arctic Grade, DFA			
Crankcase	9150-265-9435	OIL, LUBRICATING five gallon pail as follows: Grade OE 30			
	9150-265-9428	Grade OE 10			
	9150-242-7603	Grade OEA			

COMPONENT APPLICATION	NATIONAL STOCK NUMBER	DESCRIPTION	QTY REQUIRED FOR INITIAL OPERATION	QTY REQUIRED 8 HOURS OPERATION	NOTES
Radiator	6850-243-1992	Water			
	6850-174-1806	Antifreeze, inhibited glycol			
	0-I-490	Antifreeze, compound arctic			
Radiator	6850-753-4967	Inhibitor, anti-rust			
Battery	2910-209-4997	Sulphuric acid, electrolyte			



## APPENDIX C

### MAINTENANCE ALLOCATION CHART

#### Section I. INTRODUCTION

##### C-1. GENERAL.

a. This section provides a general explanation of all maintenance and repair functions authorized at various maintenance levels.

b. Section II designates overall responsibility for the performance of maintenance functions on the identified end item or component. The implementation of the maintenance functions upon the end item or component will be consistent with the assigned maintenance functions.

c. Section III lists the tools and test equipment required for each maintenance function as referenced from Section II.

d. Section IV contains supplemental instructions, explanatory notes and/or illustrations required for a particular maintenance functions.

##### C-2. EXPLANATION OF COLUMNS IN SECTION II.

a. Group Number. Column 1. The assembly group is a numerical group assigned to each assembly in a top down breakdown sequence. The applicable assembly groups are listed on the MAC in disassembly sequence beginning with the first assembly removed in a top down disassembly sequence.

b. Assembly Group. Column 2. This column contains a brief description of the components of each assembly group.

c. Maintenance Functions. Columns 3. This column lists the various maintenance functions (A through K) and indicates the lowest maintenance category authorized to perform these functions. The symbol designations for the various maintenance categories are as follows:

- C -- Operator or crew
- O -- Organizational maintenance
- F -- Direct support maintenance
- H -- General support maintenance
- D -- Depot maintenance

The maintenance functions are defined as follows:

A - Inspect. To determine serviceability of an item by comparing its physical, mechanical, and electrical characteristics with established standards.

B - Test. To verify serviceability and to detect electrical or mechanical failure by use of test equipment.

C - Service. To clean, to preserve, to charge, and to add fuel, lubricants, cooling agents, and air. If it is desired that elements, such as painting and lubricating, be defined separately, they may be so listed.

D - Adjust. To rectify to the extent necessary to bring into proper operating range.

E - Aline. To adjust specified variable elements of an item to bring to optimum performance.

F - Calibrate. To determine the corrections to be made in the readings of instruments or test equipment used in precise measurement. Consists of the comparison of two instruments, one of which is a certified standard of known accuracy, to detect and adjust any discrepancy in the accuracy of the instrument being compared with the certified standard.

G - Install. To set up for use in an operational environment such as an emplacement, site, or vehicle.

H - Replace. To replace unserviceable items with serviceable like items.

I - Repair. Those maintenance operations necessary to restore an item to serviceable condition through correction of material damage or a specific failure. Repair may be accomplished at each category of maintenance.

J - Overhaul. Normally, the highest degree of maintenance performed by the Army in order to minimize time work in process is consistent with quality and economy of operation. It consists of that maintenance necessary to restore an item to completely serviceable condition as prescribed by maintenance standard in technical publications for each item of equipment. Overhaul normally does not return an item to like new, zero mileage, or zero hour condition.

K - Rebuild. The highest degree of material maintenance. It consists of restoring equipment as nearly as possible to new conditions in accordance with original manufacturing standards. Rebuild is performed only when required by operational considerations or other paramount factors and then only at the depot maintenance category. Rebuild reduces to zero the hours or miles the equipment, or component thereof, has been in use.

d. Symbols. The uppercase letter placed in the appropriate column indicates the lowest level at which that particular maintenance function is to be performed.

c. Tools and Equipment. Column 4. This column is provided for referencing by code, the special tools and test equipment, (Section III) required to perform the maintenance functions (Section II).

f. Remarks. Column 5. This column is provided for referencing by code, the remarks (Section IV) pertinent to the maintenance functions.

### C-3. EXPLANATION OF COLUMNS IN SECTION III.

a. Reference Code. This column consists of a number and a letter separated by a dash. The number references the T and TE requirements column on the MAC. The letter represents the specific maintenance function the item is to be used with. The letter is representative of columns A through K on the MAC.

b. Maintenance Category. This column shows the lowest level of maintenance authorized to use the special tool or test equipment.

c. Nomenclature. This column lists the name or identification of the tool or test equipment.

d. Tool Number. This column lists the manufacturer's code and part number, or National Stock Number of tools and test equipment.

C-4. EXPLANATION OF COLUMNS IN SECTION IV.

a. Reference Code. This column consists of two letters separated by dash, both of which are references to Section II. The first letter references column 5 and the second letter references a maintenance function, column 3, A through K.

b. Remarks. This column lists information pertinent to the maintenance function being performed, as indicated on the MAC, Section II.





SECTION II - MAINTENANCE ALLOCATION CHART

(1) G R O U P  N O.	(2)  A S S E M B L Y G R O U P	(3) M A I N T E N A N C E F U N C T I O N S										(4)  T O O L S A N D E Q U I P M E N T	(5)  R E M A R K S		
		A	B	C	D	E	F	G	H	I	J			K	
		INSPECT	TEST	SERVICE	ADJUST	ALIGN	CALIBRATE	INSTALL	REPLACE	REPAIR	OVERHAUL			REBUILD	
03	SET CONTROLS AND INSTRUMENTATION														
	Fault Indicator Assembly	0	0						0	F			5-B	I-I	
	Printed Circuit Board	0	F						F	F				P-B, Q-H, R-I	
	Control Box Assembly	0	0						0	0					
	Voltmeters	C	0		0				0	0			5-B		
	Kilowatt Meter M7	C	F		0				0	0			5-A,B		
	Wattmeter Converter	0	F						F				29-B, 30-B,	J-B	
	Percent Rated Current Meter M9	0	F		0				0	0			31-B, 30-B	K-B	
	Rheostat/Potentiometer	0	0						0	0			5-B		
	Frequency Meter and Frequency Transducer	C	F						0	0			7-B, 32-B	L-B, M-B	
	Switches	C	0						0	0			5-B		
	Panel Lights	C	C						0	0			5-B		
	Indicator Lights	C	0						0	0			5-B		
	Oil Pressure Gage	C	0						0	0			5-B		
	Coolant Temp. Gage	C	0						0	0			5-B		
	Fuel Level Gage	C	0						0	0			5-B		
	Ammeter DC	C	0						0	0			5-B		
	Hourmeter	C	0						0	0				D-B	
	Engine Manual Speed Control	C	0						0	0					
	Relay Assembly	C	F						0	F			5-B	N-B, O-H	
	Lamps	C	C						0	0			5-B		
	Sync Lights	C	0						0	0			5-B		
	Door Holder	C							0	0					
	Cross Pin	C							0	0					
	Door	C							0	0					
	Wiring Harness	0	0						0	0		F	5-B	S-K	
	Fuel level Transmitter	0	0						0	0			5-B		
	Coolant Temp. Trans.	0	0						0	0			5-B		
	Oil Pressure Transmitter	0	0						0	0			5-B		

AIR FORCE  
ARMY  
NAVY  
MARINE CORPS

T.O. 35C2-3-442-11  
TM5-6115-600-12  
NAVFAC P-8-628-12  
TM-07464B-12

SECTION II - MAINTENANCE ALLOCATION CHART

(1) G R O U P  N O.	(2)  ASSEMBLY GROUP	(3) MAINTENANCE FUNCTIONS										(4) TOOLS AND EQUIP- MENT	(5) REMARKS		
		A	B	C	D	E	F	G	H	I	J			K	
		INSPECT	TEST	SERVICE	ADJUST	ALIGN	CALIBRATE	INSTALL	REPLACE	REPAIR	OVERHAUL			REBUILD	
04	AC ELECTRICAL CONTROL SYSTEM														
	Tactical Relay Box	O	F						F	F	H		5-B, I, J	T-B, U-I	
	Mode I Relay Assembly A27	O	F						F	F	H		5-B, I, J	V-B, W-I	
	Protective Relays	O	F						F				32-B, 30-B	Z-B, AA-D	
	Exciter Regulator	F	F		F				F	F	H		8-B, I, J, 5-B, I, J	X-B, D	
	Reconnection Board	O							O	O					
	Main Circuit Breaker	O	O						O	O	F	H		5-B, I, J	Y-I
	Load Terminal Board	O							O	O					
	Control Relays	O	F						F					5-B	AB-B, AC-D
	Convenience Receptacles	C							O	O					
	Fuse	O							O	O				5-B	
Current Transformer	O	F						F					30-B, 31-B		
Load Measuring Unit	F	F						F	F				5-B, 30-B, 31-B	AH-A, AI-B, AJ-1	
Wiring Harness	O	O						O	O		F		5-B	AK-K	
05	FUEL SYSTEM														
	Fuel Pump (Electric)	C	O	O					O					9-B	
	Fuel Filters & Strainers	C		O					O						
	Fuel Solenoid	O	O	O					O					5-B	
	Day Tank	C		C					F	F					AL-I
	Fuel Level Switch	O	O	O					O	O				5-B	
	Fuel Lines, Valves & Fittings	C							O						
Fuel Tank	C		C					F	F					AM-I	
Ether System	C							O							

SECTION II - MAINTENANCE ALLOCATION CHART

(1) G R O U P  N O.	(2)  ASSEMBLY GROUP	(3) MAINTENANCE FUNCTIONS										(4) TOOLS AND EQUIP- MENT	(5) REMARKS			
		A	B	C	D	E	F	G	H	I	J			K		
		INSPECT	TEST	SERVICE	ADJUST	ALIGN	CALIBRATE	INSTALL	REPLACE	REPAIR	OVERHAUL			REBUILD		
05 (Cont)	Fuel Injection Pump	0	F		F				F	H	D		24-H, I 11-J 11-B, 36-B, 37-B	AN-B, AO-D  AP-B, C		
	Injector Valves and Lines	0	F	F					0	F						
	Fuel Filler & Cap	C		C						0						
06	EXHAUST & BREATHER SYSTEM															
	Muffler	C							0							
	Clamps	C							0							
	Pipes & Ducts	C							0							
	Exhaust Cap	C							0							
	Breather Tube & Hoses	C							0							
07	COOLING SYSTEM															
	Radiator Shutter Assembly	0	0		0				0	0						
	Shutter Thermostat	C	0						0	F			10-B			
	Hoses & Clamps	C							0							
	Radiator	C	F	C					0	F			2-A, 9-B, 38-B			
	Water Pump	C							0	F						
	Coolant Thermostat	0	0						0				10-B			
	Fan Guards	C							0		F					
	Fan Belts	C			0				0							
08	LIFTING & SUPPORT SYSTEM															
	Lifting Frame	C							0	F						
	Control Panel Support	C							0	F						
	Front Support	C							0	F						
09	POWER GENERATOR SYSTEM															
	Generator Assembly	0	F						F	F	H	D	17-H, 18-H, 8-B, 39-B, 40-B 24-H	AQ-B, I, J, K		
	Bearings	0							F							



SECTION II - MAINTENANCE ALLOCATION CHART

(1) G R O U P  N O.	(2)  ASSEMBLY GROUP	(3) MAINTENANCE FUNCTIONS										(4) TOOLS AND EQUIP- MENT	(5) REMARKS	
		A	B	C	D	E	F	G	H	I	J			K
		INSPECT	TEST	SERVICE	ADJUST	ALIGN	CALIBRATE	INSTALL	REPLACE	REPAIR	OVERHAUL			REBUILD
10 (Cont)	Cylinder Sleeve	H							H				42-A,H, 13-A,H, 43-H,J, 44-H, 42-H, 13-H	
	Flywheel Assembly	F							F	H				
	Timing Gears	H							H					
	Camshaft	H							H					
	Camshaft Bearings	H							H					
	Crankshaft and Main Bearings	H							H				42-A,H, 13-A,H	
	Cylinder Block	H							H	H	H	D	11-H, 17-H, 18-H, 19-H	
11	SUPPORT SYSTEM Skid Base	C								F				
12	WINTERIZATION KIT FUEL BURNING													AT-B,H
	Heater Assembly	C	O	C	O				F	F				
	Valve Assembly, Regulator	F	F		O				F				14-D	
	Terminal Board	O							F					
	Switch, Limit	O	O						F				5-B	
	Receptacle Assembly	O	O						O				5-B	
	Igniter Assembly	O	F						O					
	Switch, Flame	O	O		O				O				5-B	
	Wiring Harnesses	O	O						O			F	5-B	
	Coolant Pump and Motor Assembly	F	F						F	F				
	Thermostat Swtich	O	O						O				5-B, 10-B	
	Burner Chamber	F							F					
	Heat Exchanger	F							F					
	Hoses, Lines & Fittings	C							O			O		
	Control Box Assembly	O	O					O	O	F			5-B	

AIR FORCE  
 ARMY  
 NAVY  
 MARINE CORPS

T.O. 35C2-3-442-11  
 TM5-6115-600-12  
 NAVFAC P-8-628-12  
 TM-07464B-12

SECTION II - MAINTENANCE ALLOCATION CHART

(1) G R O U P  N O.	(2)  ASSEMBLY GROUP	(3) MAINTENANCE FUNCTIONS										(4) TOOLS AND EQUIP- MENT	(5) REMARKS				
		A	B	C	D	E	F	G	H	I	J			K			
		INSPECT	TEST	SERVICE	ADJUST	ALIGN	CALIBRATE	INSTALL	REPLACE	REPAIR	OVERHAUL			REBUILD			
12 (Cont)	Light Assembly Lamp Circuit Breaker Power Switch	0	0						F								
		0	F						F								
			F						F								
13	HEATER KIT, WINTERIZATION ELEC			0				0	0	F							AU-B,H
	Coolant Pump and Motor	0	F						F	0							
	Heating Element	0	0						0	0							15-B, 16-B
	Thermostat Switch	0	0						0	0							5-B, 10-B
	Hoses and Fittings	C							0	0							
	Wiring Harness	C	0						0	0	0	F		F			5-B
	Electric Winterization Control Box	0	0					0	0	0	F						5-B
	Wiring Harness	0	0						0	0	0		F				5-B
	Transformers	F	F						0	F	F						
	Relay	F	F						0	F	F						
	Semi Conductors		F						0	F	F						
	Circuit Breaker	0	F						0	F	F						
	Power Switch	0	0	F					0	F	F						
	Fuse Holder	0							0	F	F						
	Fuse		0						0	F	F						
	Light Assembly	0	0						0	F	F						
	Indicating Lamps		C						0								

SECTION III. TOOLS, TEST AND SUPPORT EQUIPMENT REQUIREMENTS

REFERENCE CODE	MAINTENANCE CATEGORY	NOMENCLATURE	NSN
1-A	C	Tester, Battery, Electrolyte Solution	6630-171-5126
2-A	C	Tester, Antifreeze Solution	6630-247-2968
3-B	0	Carbon Pile (0 to 600 ampere load capacity)	--
4-B	0	Ammeter (0 to 50 amperes)	--
5-B	0	Multimeter	6625-553-0142
6-B	0	SPST Knife Switch (50 amperes)	--
7-B	0	Frequency Meter (0 to 100 Hertz)	--
8-B	0	Variable DC Power Supply (0- to -50 V dc)	--
9-B	0	Pressure Gage (0 to 25 psig)	--
10-B	0	Thermometer (32-212 <sup>0</sup> F: 32-100 <sup>0</sup> C)	--
11-B,H,J	0,D	Torque Wrench (150 ft lb: 203 Nm)	--
12-D	0	Torque Wrench (150 ft lb: 203 Nm)	--
13-D	0	Thickness Gage	5210-221-1999
14-D	0	Stop Watch	--
15-B	0	Wattmeter (3000 watts)	--
16-B	0	AC Ammeter (0-25 amperes)	--
17-H	F	Torque Wrench (250 ft lb; 338 Nm)	--
18-H	F	Torque Wrench (1000 ft lb, 1356 Nm)	--
19-H	F	Plastic Measuring Strips	MIL-L-P-525A

SECTION III. TOOLS, TEST AND SUPPORT EQUIPMENT REQUIREMENTS

REFERENCE CODE	MAINTENANCE CATEGORY	NOMENCLATURE	NSN
20-I	F	Spring Scale (0-16 oz; 448 grams)	--
21-J	H	Variable Speed Drive (2000 to 3000 rpm)	--
22-J	H	Carbon Pile (0 to 600 ampere load capacity)	--
23-J	H	DC Ammeter (0 to 50 amperes)	--
24-J,H,&I	H,F,D	Puller Kit, Universal	5180-701-8046
25-J	H	Spring Scale (0 to 100 pounds: 4.5 kg)	--
26-J	H	DC Ammeter (0 to 500 amperes)	--
27-J	H	Torque Arm (Pony Brake)	--
28-J	H	Hand-held Tachometer (0 to 10,000 rpm)	--
29-B	F	Digital Voltmeter	--
30-B	F	Autotransformer	--
31-B	F	AC Ammeter (0 to 5 amperes)	--
32-B	F	Variable AC Frequency Generator	--
33-B	F	Capacitor Checker	--
34-J	F	Field Service Tool Group	(11083) 5P4203
35-J	D	Tool Group	(11083) 3P220
36-B	F	Tool Test Set, Diesel Injector	4910-317-8265
37-B	F	Test Stand, Diesel Injector Pump	4910-443-0976
38-B	F	Radiator Pressure Tester	--
39-B	F	Wheatstone Bridge	--
40-B	F	500-Volt Megger	--



SECTION III. TOOLS, TEST AND SUPPORT EQUIPMENT REQUIREMENTS

REFERENCE CODE	MAINTENANCE CATEGORY	NOMENCLATURE	NSN
41-B,I	F	Governor Tool Group	(31361) 5R3633
42-I,J,K	F,H,D	Micrometers (Inside and Outside)	--
43-H,I	F,H	Locator	(11083) 958871
44-H	H	Distorter	(11083) 5P7312

Section IV. REMARKS

REFERENCE CODE	REMARKS
A-C	Hydrometer Test
B-B	Carbon Pile Dynamic Test
C-B	Normal and Overspeed Check
D-B	Time check using wristwatch
E-I	Welding of defective joints and cracks
F-J	Requires elaborate disassembly, repair and testing
G-E	Sets depth of magnetic pickup in relation to flywheel gear tooth
H-J	Requires elaborate disassembly, repair and testing
I-J	Repair by replacement of components
J-B	Capable of on-equipment testing
K-B	Capable of on-equipment testing
L-B	Frequency meter and transducer must be replaced together
M-B	Frequency transducer and meter must be replaced together
N-B	Capable of on-equipment testing

Section IV. REMARKS

REFERENCE CODE	REMARKS
O-H	Repair by replacement of components
P-B	Visual inspection using magnifier is sufficient
Q-H	Replace only if extensively damaged
R-I	Replace burnt out foil with insulated wire
S-K	Fabricate new harness if extensively damaged
T-B	Elaborate continuity check
U-I	Repair by replacement of defective components
V-B	Elaborate continuity check
W-I	Repair by replacement of defective components
X-B,D	Exiter-regulator should be tested and adjusted together
Y-I	Repair by replacement of defective components
Z-B	Test by electrically simulating fault conditions
AA-D	Cannot be adjusted
AB-B	Test by electrically simulating fault conditions
AC-D	Cannot be adjusted
AD-B	Tested by use of ohmmeter
AE-B	Visual inspection using magnifier is sufficient
AF-H	Replace only if extensively damaged
AG-I	Replace burnt out foil with insulated wire
AH-A	Visual inspection
AI-B	Capable of on-equipment testing
AJ-I	Repair by replacement of defective components
AK-K	Fabricate new harness if extensively damaged
AL-I	Repair by replacement of defective components

Section IV. REMARKS

REFERENCE CODE	REMARKS
AM-I	Repair by replacement of defective components
AN-B	Capable only of bench testing using special tools
AO-D	Requires special tools for adjusting (calibrating)
AP-B,C	Requires special tools for testing and servicing
AQ-B,I, J,K	Requires special electrical test equipment and major overhaul
AR-A,H	Engine maintenance consists of careful inspection and replacement of worn parts
AS-I	Repair is by replacement of defective or worn parts
AT-B,H	Winterization kit maintenance consisting of testing and replacement of worn parts
AU-B,H	Winterization kit maintenance consists of testing and replacement of worn parts



## **APPENDIX D ADDITIONAL AUTHORIZATION LIST**

---

### Section I. INTRODUCTION

#### **D-1. SCOPE**

This appendix lists additional items you are authorized for the support of the (enter short item name).

#### **D-2. GENERAL**

This list identifies items that do not have to accompany the (enter short item name) and that do not have to be turned in with it. These items are all authorized to you by CTA, MTOE, TDA, or JTA.

#### **D-3. EXPLANATION OF LISTING**

National stock numbers, descriptions, and quantities are provided to help you identify and request the additional items you require to support this equipment. The items are listed in alphabetical sequence by item name under the type document (i.e., CTA, MTOE, TDA, or JTA) which authorizes the item(s) to you. (Enter portions of next three sentences, only if applicable.) If the item you require differs between serial numbers of the same model, effective serial numbers are shown in the last line of the description. If item required differs for different models of this equipment, the model is shown under the "Usable on" heading in the description column.

SECTION II. ADDITIONAL AUTHORIZATION LIST

(1)  NATIONAL STOCK NUMBER	(2)  DESCRIPTION  FSCM & PART NUMBER      USABLE ON CODE		(3)  U/M	(4)  QTY AUTH
5935-00-322-8959	<p style="text-align: center;"><u>CTA AUTHORIZED ITEMS</u></p> Adapter Connector		EA	1

## INDEX

Subject	Paragraph, Figure, Table, Number
A	
AC ELECTRICAL CONTROL SYSTEM	
Controls Relays K1 and K6	
Inspect. . . . .	4-75b
Convenience Receptacles Assembly A22	
Cleaning . . . . .	4-78d
Disassembly. . . . .	4-78c
Inspection . . . . .	4-78e
Installation . . . . .	4-78h, F4-42
Reassembly . . . . .	4-78g
Removal. . . . .	4-78b
Repair . . . . .	4-78f
Current Transformers	
Inspect. . . . .	4-81
Fuses	
Inspect and replace. . . . .	4-80
Fuseholders	
Inspect. . . . .	4-79
General	
Theory of Operation. . . . .	4-68, F0-4
Load Terminal Board	
Cleaning . . . . .	4-73c
Inspection . . . . .	4-73d
Reassembly and installation . . . . .	4-73e
Removal and disassembly. . . . .	4-73b, F4-39
Main Circuit Breaker Assembly CB2	
Inspect . . . . .	4-72d
Installation . . . . .	4-72e, F4-41
Removal . . . . .	4-72d
Test . . . . .	4-72c
Mode I Relay Assembly A27	
Inspect. . . . .	4-70b
Printed Circuit Boards	
Inspect. . . . .	4-77
Protective Relays K2, K13, K14, and K15	
Inspect. . . . .	4-74b

INDEX - Continued

Subject	Paragraph, Figure, Table, Number
A - Continued	
Reconnection Board Assembly	
Cleaning . . . . .	4-71d
Disassembly . . . . .	4-71c, F4-40
Inspect . . . . .	4-71e
Installation . . . . .	4-71h, F4-40
Reassembly . . . . .	4-71g
Removal . . . . .	4-71b
Repair . . . . .	4-71f
Resistors	
Inspect . . . . .	4-76
Tactical Relay Assembly A29	
Inspect . . . . .	4-69b
Wiring Harness	
Inspect . . . . .	4-82
Overhaul, repair and test . . . . .	4-32
APPLICABILITY, LIMITED . . . . .	1-2

C

COOLING SYSTEM	
Coolant Thermostat	
Inspect . . . . .	4-105a,
Replace . . . . .	F4-55
Test . . . . .	4-105c
Theory of operation . . . . .	4-105b
Fan Guards and Belts	4-99d
Adjust (belts) . . . . .	4-107a, F4-56
Inspect . . . . .	3-16d
Replace (belts) . . . . .	4-107b
Replace (guards) . . . . .	4-106, F4-51
Theory of operation . . . . .	4-99e, f
General	
Inspect . . . . .	3-14
Operation at high altitudes . . . . .	2-17c
Operation in dusty or sandy areas . . . . .	2-13b
Operation in extreme cold . . . . .	2-11e
Operation in extreme heat . . . . .	2-12a
Operation in snow . . . . .	2-16a
Theory of operation . . . . .	4-99
Hoses and Clamps	
Inspect and replacement of clamps . . . . .	4-102b
Inspect and replacement of hoses . . . . .	4-102a



INDEX - Continued

Subject	Paragraph, Figure, Table, Number
C - Continued	
Radiator and Shutter Assembly	
Adjust . . . . .	4-100c
Cleaning . . . . .	3-18a
Coolant (check and service) . . . . .	3-14b
Disassembly and reassembly . . . . .	4-100e
Drain and refill . . . . .	3-14c
Grille removal . . . . .	4-24a
Grille replacement . . . . .	4-24b
Inspect . . . . .	4-100a, F4-51, F4-52
Repair . . . . .	4-100f
Replace . . . . .	4-100d, F4-53
Servicing . . . . .	3-14, T3-1, T4-1
Test . . . . .	4-100b
Theory of operation . . . . .	4-99b
Shutter Thermostat	
Replace . . . . .	4-101b, F4-55
Test . . . . .	4-101a
Water Pump	
Inspect . . . . .	4-104a, F4-53, F4-54
Installation . . . . .	4-104c
Removal . . . . .	4-104b
Theory of operation . . . . .	4-99c
CONSUMABLE SUPPLIES . . . . .	3-1, T3-1
CONVERSION	
Frequency . . . . .	4-6b
Of Equipment . . . . .	4-6
Voltage . . . . .	4-6a, F2-4
CRANKCASE, ENGINE	
Drain . . . . .	4-11
D	
DATA, TABULATED . . . . .	1-10, T1-1

INDEX - Continued

Subject	Paragraph, Figure, Table, Number
D - Continued	
DC ELECTRICAL AND CONTROL SYSTEM	
Alternator, Battery Charger	
Cleaning and inspection . . . . .	4-31c
Installation . . . . .	4-31d
	F4-17
Output test and adjustment . . . . .	4-31a,
	F4-16
Removal . . . . .	4-31b
Alternator, Belt	
Cleaning and Inspection . . . . .	3-9c ,
	4-30c
Installation . . . . .	4-30d
Removal . . . . .	4-30b
	F4-15
Battery Cables and slave receptacles	
Cleaning and inspection . . . . .	4-29b
Connection . . . . .	F4-14
Installation . . . . .	4-29b
Removal . . . . .	4-29b
Batteries	F4-14
Charging circuit . . . . .	4-28h(1)
Cleaning and inspection . . . . .	3-18e,f ,
	4-29a
Location . . . . .	F3-2
Maintenance . . . . .	2-9a
Operation in extreme cold . . . . .	2-11d
Operation in extreme heat . . . . .	2-11d
Reassembly and Installation . . . . .	4-29a
Removal and Disassembly . . . . .	4-29a ,
	F4-13
Servicing (activate and install) . . . . .	4-4d
Test . . . . .	4-29a
Circuit Breaker CB1, DC Control	
Inspect . . . . .	4-37a
Installation . . . . .	4-37d ,
	F4-21
Removal . . . . .	4-37b
Test . . . . .	4-37c
Fuel Shutdown Solenoid L1	
Inspect . . . . .	4-40b
Removal . . . . .	4-40c ,
	F4-25 ,
	F4-63

INDEX - Continued

Subject	Paragraph, Figure, Table, Number
D - Continued	
Replacement . . . . .	4-40e
Test . . . . .	4-40d
General	
Maintenance . . . . .	4-27, F4-25
Theory of Operation . . . . .	4-28
High Coolant Temperature Switch WT	
Inspect . . . . .	4-35b
Installation . . . . .	4-35e
Removal . . . . .	4-35d, F4-19
Test, on generator set . . . . .	4-35c
Theory of operation . . . . .	4-28d, 4-35
Low Oil Pressure Switch Op	
Bench test . . . . .	4-34d
Installation . . . . .	4-34e
Removal . . . . .	4-34c
Test, on generator set . . . . .	4-34b
Theory of operation . . . . .	4-28d, 4-34b
Magnetic Pickup	
Inspect . . . . .	3-9d
Removal and installation . . . . .	4-33c
Theory of operation . . . . .	4-33a
Receptacle, Slave	
Cleaning and inspection . . . . .	4-29b
Inspect . . . . .	3-9b
Installation . . . . .	4-29b
Maintenance . . . . .	3-9b
Removal . . . . .	4-29b
Relays K3, K5, K7, and K8	
Cleaning . . . . .	4-36c
Inspection . . . . .	4-36b
Installation . . . . .	4-36f
Removal . . . . .	4-36a, F4-20
Testing, K3 . . . . .	4-36d
Testing K5, K7, and K8 . . . . .	4-36e
Speed Switch	
Inspect . . . . .	4-33b
Removal and installation . . . . .	4-33c, F4-28b,
Theory of operation . . . . .	4-33a

INDEX - Continued

Subject Paragraph,  
Figure, Table,  
Number

D - Continued

Starter Assembly	
Inspect . . . . .	3-9e, F4-24
Installation . . . . .	4-39d
Protection, theory . . . . .	4-28a
Removal . . . . .	4-39c, F4-14, F4-23
Test . . . . .	4-39b, F4-22
Switches	
Inspect . . . . .	3-10c
Maintenance procedures . . . . .	4-38
Wiring Harness	
Cleaning . . . . .	4-32d
General . . . . .	4-32a, F0-1,2
Inspection . . . . .	4-32e
Installation . . . . .	4-32g, F4-18
Removal . . . . .	4-32c
Repair . . . . .	4-32f
Test, on generator set . . . . .	4-32b
DEFICIENCY REPORT, REPORTING EQUIPMENT . . . . .	1-13
DESTRUCTION TO PREVENT ENEMY USE . . . . .	1-6

E

ELECTRIC WINTERIZATION KIT	
Control Box, Wiring Harness, Power Switch, Fuse Holder, Fuse light Assembly, and Indicating Lamps	
Inspect . . . . .	5-35a, F5-13
Install control box . . . . .	5-35e
Repair wiring harness . . . . .	5-35g
Replace control box . . . . .	5-35d
Replace fuse . . . . .	5-35e
Replace indicating lamp . . . . .	5-35f
Test . . . . .	5-35b
Coolant Pump and Motor	
Inspect . . . . .	5-30a, F5-10
Repair . . . . .	5-30b

INDEX - Continued

Subject	Paragraph, Figure, Table, Number
E - Continued	
General	
Inspect . . . . .	5-27a, F5-9
Installation . . . . .	5-23
Maintenance . . . . .	5-25, 5-27
Operation . . . . .	2-9
Replace. . . . .	5-29c
Test . . . . .	5-27b, 5-29a
Theory of operation. . . . .	5-22, F1-8, F1-9
Troubleshooting . . . . .	5-26
Heating Element	
Inspect . . . . .	5-31a, F5-11
Replace. . . . .	5-31c
Test . . . . .	5-31b
Hoses and Fittings	
Inspect and replace. . . . .	5-33
Operating instructions . . . . .	F2-13
Thermostat Switch	
Inspect. . . . .	5-32a
Replace. . . . .	5-32c
Test . . . . .	5-32b
Wiring Harness	
Repair . . . . .	5-34c, F5-12
Replace. . . . .	5-34b
Test . . . . .	5-34a
ELECTRICAL SCHEMATICS	
AC System. . . . .	F0-4
AC Control System, Inspect . . . . .	3-11
DC System . . . . .	F0-5
Exciter-Regulator A11 . . . . .	F0-6
Fault Indicator Panel A9 . . . . .	F1-5
EMERGENCY (BATTLE SHORT) OPERATION	
Emergency Operation . . . . .	2-18b, F2-16
Emergency Shutdown . . . . .	2-18c, F2-6ref
General . . . . .	2-18a

INDEX - Continued

Subject Paragraph,  
 Figure, Table,  
 Number

E - Continued

ENGINE

Air Cleaner

Cleaning . . . . . 3-16a  
 Inspect. . . . . 3-16b  
 Installation . . . . . 4-116a(4)  
 Operation in dusty or sandy areas. . . . . 2-13e  
 Replace. . . . . 4-115  
 F4-60

Cylinder Head Assembly

Inspect. . . . . 4-124,  
 F4-68

Exhaust Manifold

Inspect. . . . . 4-123a,  
 F4-67  
 Installation . . . . . 4-123c  
 Removal and replacement. . . . . 4-123b

Fan Assembly

Inspect. . . . . 3-16d  
 Replacement. . . . . 4-119,  
 F4-64

General

Fault indicators . . . . . 4-28e  
 Inspect. . . . . 3-16,  
 4-114  
 Operation. . . . . 4-28f  
 Operation in extreme heat. . . . . 2-12f  
 Protection, theory . . . . . 4-28d  
 Starting, theory . . . . . 4-28a  
 Stopping, theory . . . . . 4-28c

Governor

Adjustment . . . . . 4-118b  
 Inspect. . . . . 4-118a  
 Installation . . . . . 4-118d,  
 F4-63  
 Removal. . . . . 4-118c

Governor Throttle Linkage

Adjust . . . . . 4-117a,  
 F4-62  
 Inspect. . . . . 3-16c  
 Replace. . . . . 4-117b

Idler Pulley Assembly

Inspect. . . . . 4-122a,  
 F4-66  
 Replacement. . . . . 4-122b

INDEX - Continued

Subject	Paragraph, Figure, Table, Number
E - Continued	
Oil Cooler	
Inspect . . . . .	4-121a
Replace . . . . .	4-121b, F4-65
Oil Filter	
Inspect . . . . .	3-16e
Service and replacement . . . . .	F4-8
Oil Pan	
Inspect . . . . .	3-16f
Rocker Arms and Valves	
Inspect . . . . .	4-125b
Installation . . . . .	4-125d
Removal of valve cover. . . . .	4-125a F4-68
Valve Lash adjustment . . . . .	4-125c, F4-69
Turbocharger	4-116a
Inspect . . . . .	4-116a
Replace . . . . .	4-116b, F4-61
ERRORS, REPORTING OF . . . . .	1-4
EXHAUST AND BREATHER SYSTEM	
Breather Tube and Hoses . . . . .	
Check . . . . .	3-13d
Installation . . . . .	4-98b
Removal . . . . .	4-98a
Exhaust Cap (Rain)	
Check . . . . .	3-13c, 4-96
Installation . . . . .	4-97b
Removal and replacement . . . . .	4-97a
Exhaust Pipes and Ducts	
Inspect . . . . .	4-96
Installation . . . . .	4-97b
Removal and replacement . . . . .	4-97a
General	
Inspect . . . . .	3-13, 4-96, F4-50
Theory of operation . . . . .	4-95
Muffler and Clamps	
Inspect . . . . .	3-13a
Install . . . . .	4-97b, F4-50
Removal and replacement . . . . .	4-97a

INDEX - Continued

Subject	Paragraph, Figure, Table, Number
F	
Field Flash Circuit	4-28h
FUEL BURNING WINTERIZATION KIT	
Circuit Breaker	
Inspect. . . . .	5-21, F5-7
Control Box Assembly	
Inspection . . . . .	5-18a, F2-11, F5-1
Installation . . . . .	5-18c
Replacement . . . . .	5-18d
Test . . . . .	5-18b
Flame Switch	
Adjust . . . . .	5-14b
Test . . . . .	5-14a
General	
Inspect. . . . .	5-6
Installation . . . . .	5-2, F5-1
Maintenance. . . . .	5-4, F5-3
Operation . . . . .	2-8, F1-6, F1-7
Service . . . . .	5-6b, F5-2
Test . . . . .	5-6c
Theory of operation. . . . .	5-1
Troubleshooting. . . . .	5-5
Heater Assembly	
Adjust . . . . .	5-8b
Test . . . . .	5-8a
Theory of operation. . . . .	5-8
Hoses, Lines and Fittings	
Rebuild. . . . .	5-17b
Replace. . . . .	5-17a
Igniter Assembly	
Inspect. . . . .	5-13a
Replace. . . . .	5-13b, F5-4
Lamp	
Replace. . . . .	F5-8
Light Assembly	
Inspect. . . . .	5-19a
Test . . . . .	5-19b



INDEX - Continued

Subject	Paragraph, Figure, Table, Number
F - Continued	
Limit Switch	
Inspect. . . . .	5-11a
Test . . . . .	5-11b
Operating instructions . . . . .	F2-12
Receptacle Assembly	
Inspect. . . . .	5-12a, F5-3
Replace. . . . .	5-12c
Test . . . . .	5-12b
Regulator Valve Assembly	
Adjust and service . . . . .	5-9, F5-3
Terminal Board	
Inspect. . . . .	5-10, F5-3
Thermostat Switch	
Inspect. . . . .	5-16a
Replacement. . . . .	5-16c
Test . . . . .	5-16b
Wiring Harness	
Inspect. . . . .	5-15a, F5-5, F5-6
Repair . . . . .	5-15d
Replace. . . . .	5-15c
Test . . . . .	5-15b
FUEL SYSTEM	
Day Tank	
Inspect and service. . . . .	3-12c
Theory of operation. . . . .	4-83f
Ether System	
Inspect. . . . .	3-12g
Replace. . . . .	4-91b
Servicing. . . . .	4-91a, F4-47
Starting . . . . .	2-11c, F2-15
Theory of operation. . . . .	4-28g
Fuel Connection, Auxiliary	
Use of . . . . .	4-5f,
Fuel Filler Cap and Strainer	
Inspect. . . . .	F4-6
Replace. . . . .	3-12h
Service. . . . .	4-94, F3-3, 3-12h

INDEX - Continued

Subject	Paragraph, Figure, Table, Number
F - Continued	
Fuel Injection Pump, Valves and Lines	
Inspect (pump) . . . . .	4-92a
Inspect (valves and lines) . . . . .	4-93c, F4-48, F4-49
Replace (lines) . . . . .	4-93b
Replace (valves). . . . .	4-93c
Theory of operation . . . . .	4-83h
Fuel Level Switches FL1 and FL2	
Inspect . . . . .	4-89a, F4-46
Replace . . . . .	4-89d
Service . . . . .	4-89c
Test. . . . .	4-89b
Fuel Lines, Valves and Fittings	
Bleeding. . . . .	4-87b
Inspect . . . . .	3-12d
Removal and replacement . . . . .	4-90, F4-43 through F4-46
Fuel Solenoid Valve L2	
Inspect . . . . .	4-88a, F4-44
Replace . . . . .	4-88d
Service . . . . .	4-88c
Test. . . . .	4-88b
Theory of operation . . . . .	4-83e
Fuel Strainers	
Inspect . . . . .	3-12b
Theory of operation . . . . .	4-83d, F4-44
Fuel System	
At high altitudes . . . . .	2-17d
Bleeding. . . . .	4-87
General . . . . .	2-11b F1-4
In dusty or sandy areas . . . . .	2-13d
In extreme cold . . . . .	2-11b
In extreme heat . . . . .	2-12c
Inspect . . . . .	3-12b
Theory of operation . . . . .	4-83
Under rainy or humid conditions . . . . .	2-14a

INDEX - Continued

Subject	Paragraph, Figure, Table, Number
F - Continued	
Fuel Tank	
Drain . . . . .	3-12f
Inspect . . . . .	3-12e
Service . . . . .	3-12e
Theory of operation . . . . .	4-83a
Fuel Transfer Pumps (Electric) B2 and B3	
Inspect . . . . .	3-12a
Replacement . . . . .	4-84c
Service . . . . .	4-84b
Test . . . . .	4-84a, F4-43
Theory of operation . . . . .	4-83c
Primary Fuel Filter and Strainer	
Inspect . . . . .	3-12b
Replace . . . . .	4-85b, F4-44
Service . . . . .	4-85a
Theory of operation . . . . .	4-83d
Secondary Fuel Filter	
Replace . . . . .	4-86b
Service . . . . .	4-86a, F4-45
Theory of operation . . . . .	4-83g, F1-4

G

GENERATOR SET	
Cleaning . . . . .	3-18
Controls and Indicators . . . . .	2-2, 4-41,
Description . . . . .	1-9 F1-1, F1-2, F4-3,
Grounding . . . . .	4-5e F4-5,
Inspection and Servicing . . . . .	4-4, F4-2, F4-60
Installation . . . . .	4-5, F4-4,
Leveling . . . . .	4-5d
Movement to a New Work Site . . . . .	4-7
Operation at High Altitudes . . . . .	2-17

INDEX - Continued

Subject	Paragraph, Figure, Table, Number
G - Continued	
Operating, in Parallel. . . . .	2-5 F2-7, F2-8 F2-9,
Operating, Single Unit. . . . .	2-4 F2-6.
Protection From Salt. . . . .	2-15b
Protection From Snow. . . . .	2-16b
Starting . . . . .	2-3 F2-5,
Stopping . . . . .	2-6
Theory of Parallel Operation. . . . .	F2-10 F4-68b
Theory of Single Unit Operation . . . . .	4-68a
Unloading . . . . .	4-2,
Unpacking . . . . .	4-3,
See also: Operating Procedures	F4-1

H

HOUSING

Access Doors	
Inspect . . . . .	F4-10
Removal . . . . .	4-21a
Replacement . . . . .	4-21b
Door Seals . . . . .	F4-11
Air Intake Louvers	
Removal . . . . .	4-26a
Replacement . . . . .	4-26b, F4-10
Covers	
Removal . . . . .	4-22a
Replacement . . . . .	4-22b, F4-10
General	
Inspect . . . . .	3-8
Maintain . . . . .	3-8, 4-20
Hinges and Latches	
Inspect . . . . .	3-8
Identification Plates, Location . . . . .	F1-3
Radiator Grille	
Removal . . . . .	4-24a
Replacement . . . . .	4-24b
Tool Box	
Inspect . . . . .	4-25
Removal . . . . .	4-25a
Replacement . . . . .	4-25b, F4-12

INDEX - Continued

Subject Paragraph,  
 Figure, Table,  
 Number

H - Continued

Panels  
 Removal . . . . . 4-23a  
 Replacement . . . . . 4-23b  
 F4-10

I

INSPECTION, FOR LIMITED STORAGE . . . . . 1-8  
 INTRODUCTION, GENERAL . . . . . 1-1

L

LIFTING AND SUPPORT SYSTEM

Control Panel Support and Front Support  
 Inspect . . . . . 3-15  
 Replace . . . . . 4-110  
 Lifting Frame  
 Inspect . . . . . 3-15  
 Replace . . . . . 4-109  
 F4-57

LIMITED STORAGE, PREPARATION FOR . . . . . 1-8  
 LOAD CONNECTION . . . . . 4-59

LUBRICATION

Crankcase Oil Level . . . . . 3-3e  
 Detailed Information . . . . . 3-3  
 Diagram . . . . . F3-1  
 General . . . . . 3-3,  
 F4-8  
 In Dusty or Sandy Areas . . . . . 2-13c  
 In Extreme Heat . . . . . 2-12b  
 Crankcase oil . . . . . 3-3e

M

MAINTENANCE

Accomplishment, Levels of . . . . . 1-5  
 Preventative Checks and Services . . . . . 3-4  
 T3-2  
 T4-2  
 4-13  
 Repairs Parts . . . . . 4-9  
 METERS AND GAGES . . . . . 3-10a,  
 F2-2

INDEX - Continued

Subject	Paragraph, Figure, Table, Number
0	
OPERATING PROCEDURES	
Emergency Operation . . . . .	F2-16
General. . . . .	2-1
In Dusty or Sandy Areas . . . . .	2-13
In Extreme Cold . . . . .	2-11
In Extreme Heat . . . . .	2-12
In Salt Water Areas . . . . .	2-15
In Snow . . . . .	2-16
Under Rainy or Humid Conditions . . . . .	2-14
P	
PLATES, IDENTIFICATION . . . . .	1-10, F1-3
POWER GENERATION SYSTEM	
Bearing	
Inspect . . . . .	4-113
Generator Assembly	
Inspect . . . . .	4-112
R	
RADIO INTERFERENCE SUPPRESSION	
General . . . . .	4-16
Diode Assembly . . . . .	4-17
Replacement . . . . .	4-18,
Test . . . . .	4-19
RECOMMENDATIONS, REPORTING EQUIPMENT IMPROVEMENT . . . . .	1-12
RECORDS, MAINTENANCE . . . . .	1-3
RUST PREVENTION . . . . .	2-14b
S	
SET CONTROLS AND INSTRUMENTATION . . . . .	F2-1, F2-2
Battery Charging Ammeter M4	
General . . . . .	4-57a
Replacement . . . . .	4-57c, F4-28
Test. . . . .	4-57b
Control Box Assembly A 3	
Inspect . . . . .	4-43b
Repair. . . . .	4-43e, F2-2

INDEX - Continued

Subject	Paragraph, Figure, Table, Number
S - Continued	
Replace . . . . .	4-43d
Test. . . . .	4-43c
Coolant Temperature Gage M2	
Inspect . . . . .	4-56a
Replacement . . . . .	4-56c, F4-37
Test, on equipment. . . . .	4-56b
Coolant Temperature Transmitter MT2	
Inspect . . . . .	4-66b
Installation . . . . .	4-66e
Removal . . . . .	4-66d, F4-19
Test, on equipment . . . . .	4-66c
Cross Pin	
Inspect . . . . .	4-63b
Replace . . . . .	4-63c
Door Holder	
Inspect . . . . .	4-62b
Replace . . . . .	4-62c
Engine Manual Speed Control	
Adjust . . . . .	4-59e
Installation . . . . .	4-59d
Removal . . . . .	4-59c,
Test. . . . .	4-59b
Fault Indicator Assembly A9	
Bench test . . . . .	4-42c
Inspect . . . . .	4-42a
Replacement . . . . .	4-42d, F4-26, F2-3
Test, on generator set . . . . .	4-42b, F4-27 F1-5
Fuel Level Gage M3	
General . . . . .	4-55a
Replacement . . . . .	4-55c, F4-37
Test, on generator set. . . . .	4-55b, F4-37
Fuel Level Transmitter MT3	
General . . . . .	4-67b
Replace . . . . .	4-67d
Test. . . . .	4-67c
Frequency Meter M6 and Frequency Transducer A2	
Inspect . . . . .	4-49b
Replace . . . . .	4-49c, F4-30

INDEX - Continued

Subject	Paragraph, Figure, Table, Number
S - Continued	
Kilowatts Meter M7	
Adjust . . . . .	4-45b
Replacement . . . . .	4-45c
Lights, Panel and Indicator, DS1, DS2, and DS3	
General . . . . .	4-52, 4-53, 4-28h,
Replacement . . . . .	4-52b, 4-53c, F4-35, F4-36
Test . . . . .	4-53b
Oil Pressure Gage M1	
General . . . . .	4-54a
Removal and Installation . . . . .	F4-37
Test, on generator set . . . . .	4-54b
Oil Pressure Transmitter	
Installation . . . . .	4-65d
Removal . . . . .	4-65c, F4-19
Test, on generator set . . . . .	4-65b
Percent Rated Current Meter M8	
Adjust . . . . .	4-47b
General . . . . .	4-47a
Replace . . . . .	4-47c, F4-28
Relay Assembly A4	
Inspect . . . . .	4-60b
Replace . . . . .	4-60c
Running Time Meter M5	
General . . . . .	4-58a
Replace . . . . .	4-58c, F4-28
Test . . . . .	4-58b
Switches	
Amps-Volts Selector S8	
Removal and replacement . . . . .	4-51c F4-34
Test . . . . .	4-51b F4-33
Toggle	
Replacement . . . . .	4-50, F4-31
Test . . . . .	4-50b



INDEX - Continued

Subject	Paragraph, Figure, Table, Number
S - Continued	
Synchronizing Lights DS4 and DS5	
Inspect . . . . .	4-61 b
Removal or Replacement . . . . .	4-61 d, F4-34
Test . . . . .	4-61 c
Thermal Watt Converter A1	
Inspect . . . . .	4-46
Voltage Adjust Rheostat R2	
Inspect . . . . .	4-48 b
Replacement . . . . .	4-48 d, F4-29
Test . . . . .	4-48 c
Volts AC Meter M9	
Adjust . . . . .	4-44 b
General . . . . .	4-44 a
Replacement . . . . .	4-44 d F4-28
Test, on generator set. . . . .	4-44 c
Wiring Harnesses	
General . . . . .	4-64 a
Replacement . . . . .	4-64 c
Test . . . . .	4-64 b
SHIPMENT	
Loading Equipment . . . . .	1-8
Preparation . . . . .	1-8
SPEED CONTROL, ENGINE MANUAL	
Inspect . . . . .	3-10 d
STORAGE, ADMINISTRATIVE . . . . .	1-7
STORAGE, PREPARATION . . . . .	1-8
SUPPLIES, MAINTENANCE AND OPERATION . . . . .	T3-1
SUPPORT SYSTEM	
Skid Base	
Inspect . . . . .	3-17
T	
TORQUE DATA . . . . .	T1-2
TROUBLESHOOTING	
AC System . . . . .	F0-1
DC System . . . . .	F0-2
General . . . . .	3-6, T3-3, T4-3



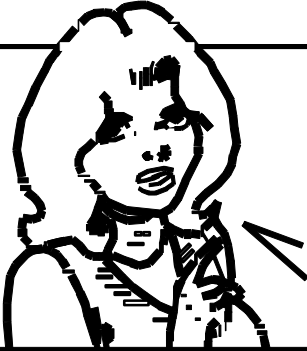

THEN ... JOT DOWN THE INFO ABOUT IT ON THIS FORM. CAREFULLY TEAR IT OUT. FOLD IT AND DROP IT IN THE MAIL.

**SOMETHING WRONG WITH THIS PUBLICATION**

FROM: (PRINT YOUR UNIT'S COMPLETE ADDRESS)  
 Commander  
 Stateside Army Depot  
 ATTN: AMSTA-US  
 Stateside, N.J. 07703-5007

---

DATE SENT  
 10 July 1975

PUBLICATION NUMBER <b>TM 11-5840-340-20</b>	PUBLICATION DATE <b>23 Jan 74</b>	PUBLICATION TITLE <b>Radar Set AN/PRC-76</b>
--	--------------------------------------	---

BE EXACT PIN-POINT WHERE IT IS				IN THIS SPACE TELL WHAT IS WRONG AND WHAT SHOULD BE DONE ABOUT IT:
PAGE NO	PARA GRAPH	FIGURE NO	TABLE NO	
2-25	2-28			Recommend that the installation antenna alignment procedure be changed throughout to specify a 20 IFF antenna lag rather than 10.  REASON: Experience has shown that with only a 10 lag, the antenna servo system is too sensitive to wind gusting in excess of 25 knots, and has a tendency to rapidly accelerate and decelerate as it hunts, causing strain to the drive train. Hunting is minimized by adjusting the lag to 20 without degradation of operation.
3-10	3-3		3-1	Item 5, Functional column. Change • 2 dB" to • 3 dB".  REASON: The adjustment procedure for the TRANS POWER FAULT indicator calls for a 3 dB (500 watts) adjustment to light the TRANS POWER FAULT indicator.
5-6	5-8			Add new step f.1 to read, • Replace cover plate removed in step f.1, above."  REASON: To replace the cover plate.
		FO-3		Zone C 3. On J1-2, change • +24 VDC" to • +5 VDC".  REASON: This is the output line of the 5 VDC power supply. +24 VDC is the input voltage.

TEAR ALONG DOTTED LINE

PRINTED NAME, GRADE OR TITLE AND TELEPHONE NUMBER <b>SSG I. M. DeSpirito 999-1776</b>	SIGN HERE 
--	---------------

FILL IN YOUR  
UNIT'S ADDRESS

FOLD BACK

DEPARTMENT OF THE ARMY

\_\_\_\_\_  
\_\_\_\_\_

OFFICIAL BUSINESS

PLEASE  
AFFIX  
STAMP  
POSTAGE  
REQUIRED

**SAMPLE**

Commander  
U.S. Army Communications-Electronics Command  
and Fort Monmouth  
ATTN: AMSEL-LC-LEO-D-CS-CFO  
Fort Monmouth, New Jersey 07703-5006

TEAR ALONG DOTTED LINE

# SOMETHING WRONG WITH THIS PUBLICATION



THEN ... JOT DOWN THE INFO ABOUT IT ON THIS FORM. CAREFULLY TEAR IT OUT. FOLD IT AND DROP IT IN THE MAIL.

FROM: (PRINT YOUR UNIT'S COMPLETE ADDRESS)

DATE SENT

PUBLICATION NUMBER

PUBLICATION DATE

PUBLICATION TITLE

BE EXACT PIN-POINT WHERE IT IS

IN THIS SPACE TELL WHAT IS WRONG AND WHAT SHOULD BE DONE ABOUT IT:

PAGE NO

PARA GRAPH

FIGURE NO

TABLE NO

TEAR ALONG DOTTED LINE

PRINTED NAME, GRADE OR TITLE AND TELEPHONE NUMBER

SIGN HERE

FILL IN YOUR  
UNIT'S ADDRESS

FOLD BACK

DEPARTMENT OF THE ARMY

\_\_\_\_\_  
\_\_\_\_\_

OFFICIAL BUSINESS

PLEASE  
AFFIX  
STAMP  
POSTAGE  
REQUIRED

TEAR ALONG DOTTED LINE

**Commander**  
**U.S. Army Communications-Electronics Command**  
**and Fort Monmouth**  
**ATTN: AMSEL-LC-LEO-D-CS-CFO**  
**Fort Monmouth, New Jersey 07703-5006**

# SOMETHING WRONG WITH THIS PUBLICATION



THEN ... JOT DOWN THE INFO ABOUT IT ON THIS FORM. CAREFULLY TEAR IT OUT. FOLD IT AND DROP IT IN THE MAIL.

FROM: (PRINT YOUR UNIT'S COMPLETE ADDRESS)

DATE SENT

PUBLICATION NUMBER

PUBLICATION DATE

PUBLICATION TITLE

BE EXACT PIN-POINT WHERE IT IS

IN THIS SPACE TELL WHAT IS WRONG AND WHAT SHOULD BE DONE ABOUT IT:

PAGE NO

PARA GRAPH

FIGURE NO

TABLE NO

TEAR ALONG DOTTED LINE

PRINTED NAME, GRADE OR TITLE AND TELEPHONE NUMBER

SIGN HERE

FILL IN YOUR  
UNIT'S ADDRESS

FOLD BACK

DEPARTMENT OF THE ARMY

\_\_\_\_\_  
\_\_\_\_\_

OFFICIAL BUSINESS

PLEASE  
AFFIX  
STAMP  
POSTAGE  
REQUIRED

TEAR ALONG DOTTED LINE

**Commander**  
**U.S. Army Communications-Electronics Command**  
**and Fort Monmouth**  
**ATTN: AMSEL-LC-LEO-D-CS-CFO**  
**Fort Monmouth, New Jersey 07703-5006**



# SOMETHING WRONG WITH THIS PUBLICATION



THEN ... JOT DOWN THE INFO ABOUT IT ON THIS FORM. CAREFULLY TEAR IT OUT. FOLD IT AND DROP IT IN THE MAIL.

FROM: (PRINT YOUR UNIT'S COMPLETE ADDRESS)

DATE SENT

PUBLICATION NUMBER

PUBLICATION DATE

PUBLICATION TITLE

BE EXACT PIN-POINT WHERE IT IS

IN THIS SPACE TELL WHAT IS WRONG AND WHAT SHOULD BE DONE ABOUT IT:

PAGE NO

PARA GRAPH

FIGURE NO

TABLE NO

TEAR ALONG DOTTED LINE

PRINTED NAME, GRADE OR TITLE AND TELEPHONE NUMBER

SIGN HERE

FILL IN YOUR  
UNIT'S ADDRESS

FOLD BACK

DEPARTMENT OF THE ARMY

\_\_\_\_\_  
\_\_\_\_\_

OFFICIAL BUSINESS

PLEASE  
AFFIX  
STAMP  
POSTAGE  
REQUIRED

TEAR ALONG DOTTED LINE

**Commander  
U.S. Army Communications-Electronics Command  
and Fort Monmouth  
ATTN: AMSEL-LC-LEO-D-CS-CFO  
Fort Monmouth, New Jersey 07703-5006**

By Order of the Secretary of the Army:

Official:

  
JOEL B. HUDSON  
*Administrative Assistant to the  
Secretary of the Army*  
0214312

ERIC K. SHINSEKI  
*General, United States Army  
Chief of Staff*

By Order of the Secretary of the Air Force:

Official:

GEORGE T. BABBITT  
*General, United States Air Force  
Commander, AFMC*

JOHN P. JUMPER  
*General, United States Air Force  
Chief of Staff*

By Order of the Secretary of the Navy:

WALTER H. CANTRELL  
*Rear Admiral, United States Navy  
Commander, Space and Naval Warfare  
Systems Command*

By Order of the Secretary of the Marine Corps:

RANDALL P. SHOCKEY  
*Director, Program Support  
Marine Corps Systems Command*

DISTRIBUTION:

To be distributed in accordance with the initial distribution number (IDN) 250862 requirements for TM 5-6115-600-12.

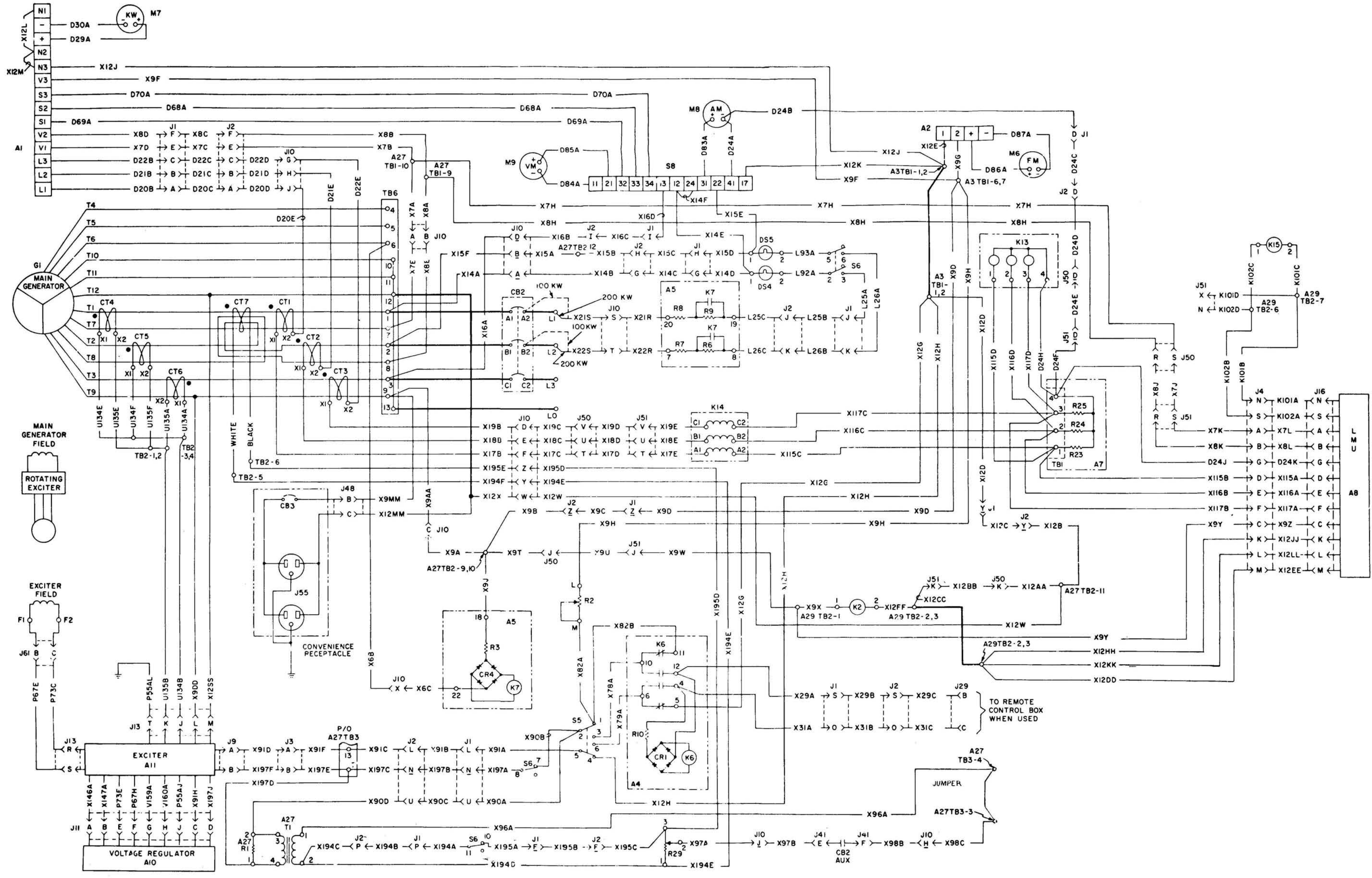

- A1 CONVERTER, THERMAL WATT
- A2 CONVERTER, FREQUENCY
- A3 CONTROL CUBICLE
- A4 CONTROL PANEL RELAY ASSEMBLY
- A5 DC RELAY ASSEMBLY

- A7 RESISTOR ASSY, CURRENT XFMR LOAD
- A8 LOAD MEASURING UNIT
- A10 VOLTAGE REGULATOR ASSY
- A11 EXCITER ASSEMBLY

- A27 SPECIAL RELAY BOX
- A29 TACTICAL RELAY BOX
- CB2 CIRCUIT BREAKER ASSEMBLY
- CB3 CIRCUIT BREAKER, CONVENIENCE RCPT
- CR1 DIODE, FULL WAVE BRIDGE
- CR4 DIODE, FULL WAVE BRIDGE

- DS4, DS5 LIGHT, SYNCHRONIZING
- G1 GENERATOR
- K2 RELAY, OVER VOLTAGE
- K6 RELAY, REMOTE VOLTAGE SENSING
- K7 RELAY, PAR LIGHTS VOLTAGE SENSOR

- K13 RELAY, SHORT CIRCUIT
- K14 RELAY, OVERLOAD
- K15 RELAY, REVERSE POWER

- M6 METER, FREQUENCY
- M7 METER, KILOWATT
- M8 AMMETER, AC
- M9 VOLTMETER

- R2 RHEOSTAT, VOLTAGE ADJUSTING
- R3, R4, R5 RESISTOR
- R6, R7, R8 RESISTOR
- R9, R10, R23 RESISTOR
- R24, R25 RESISTOR

- R29 RHEOSTAT, REACTIVE CURRENT
- S5 SWITCH, LOCAL-REMOTE VOLTAGE
- S6 SWITCH, UNIT PARALLEL
- S8 SWITCH, AMMETER-VOLTMETER XFR

- TB6 TERMINAL BOARD RECONNECTION

TB6		
TERMINALS CONNECTED TOGETHER		
120/208 VOLT CONNECTION	240/416 VOLT CONNECTION	
1-7	4-10	4-7
2-8	5-11	5-8
3-9	6-12	6-9

F0-1. AC Troubleshooting Diagram







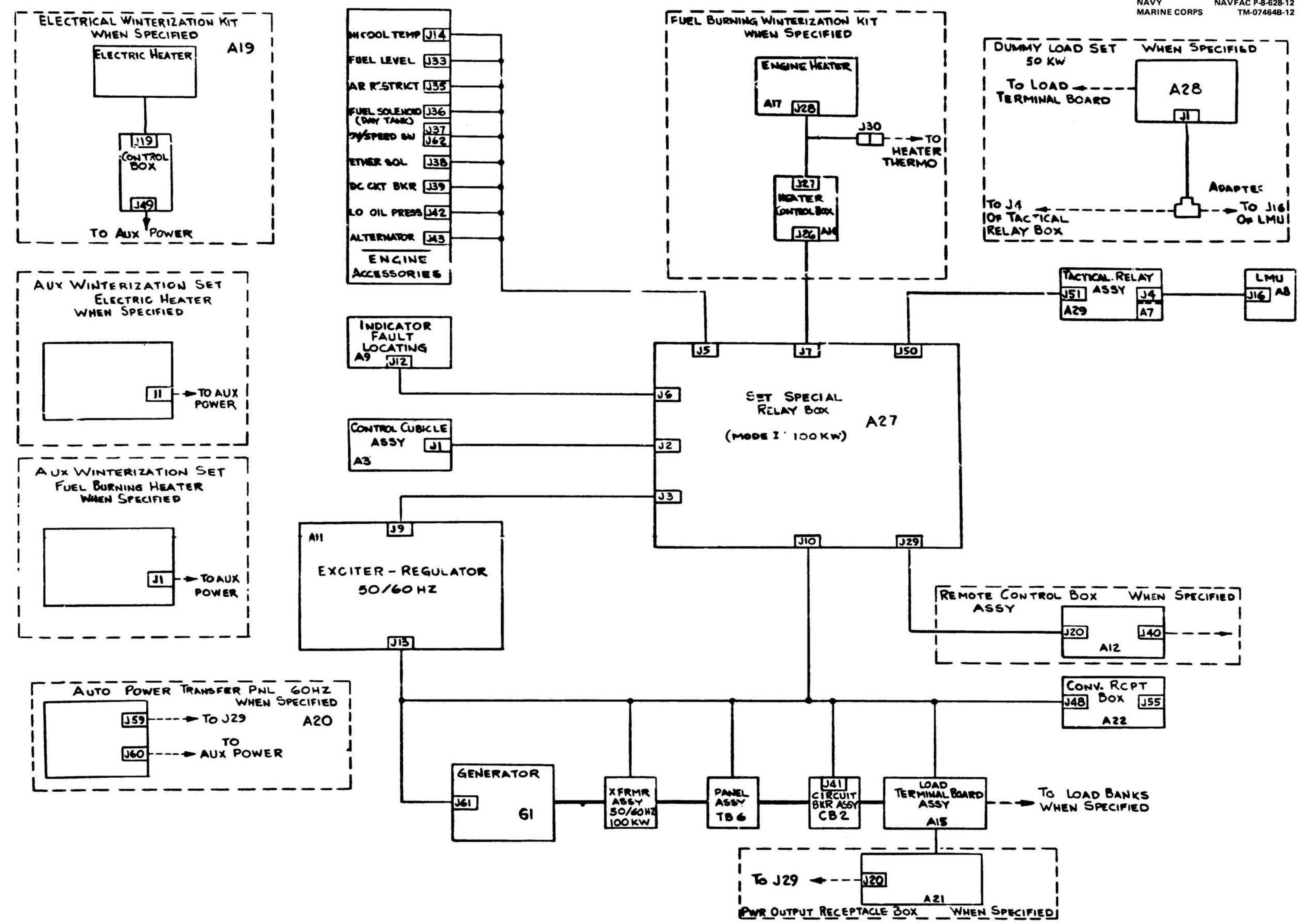

F0-3. Generator Set Inter-connection Diagram





AC SCHEMATIC DIAGRAM 50/60 HZ 100KW

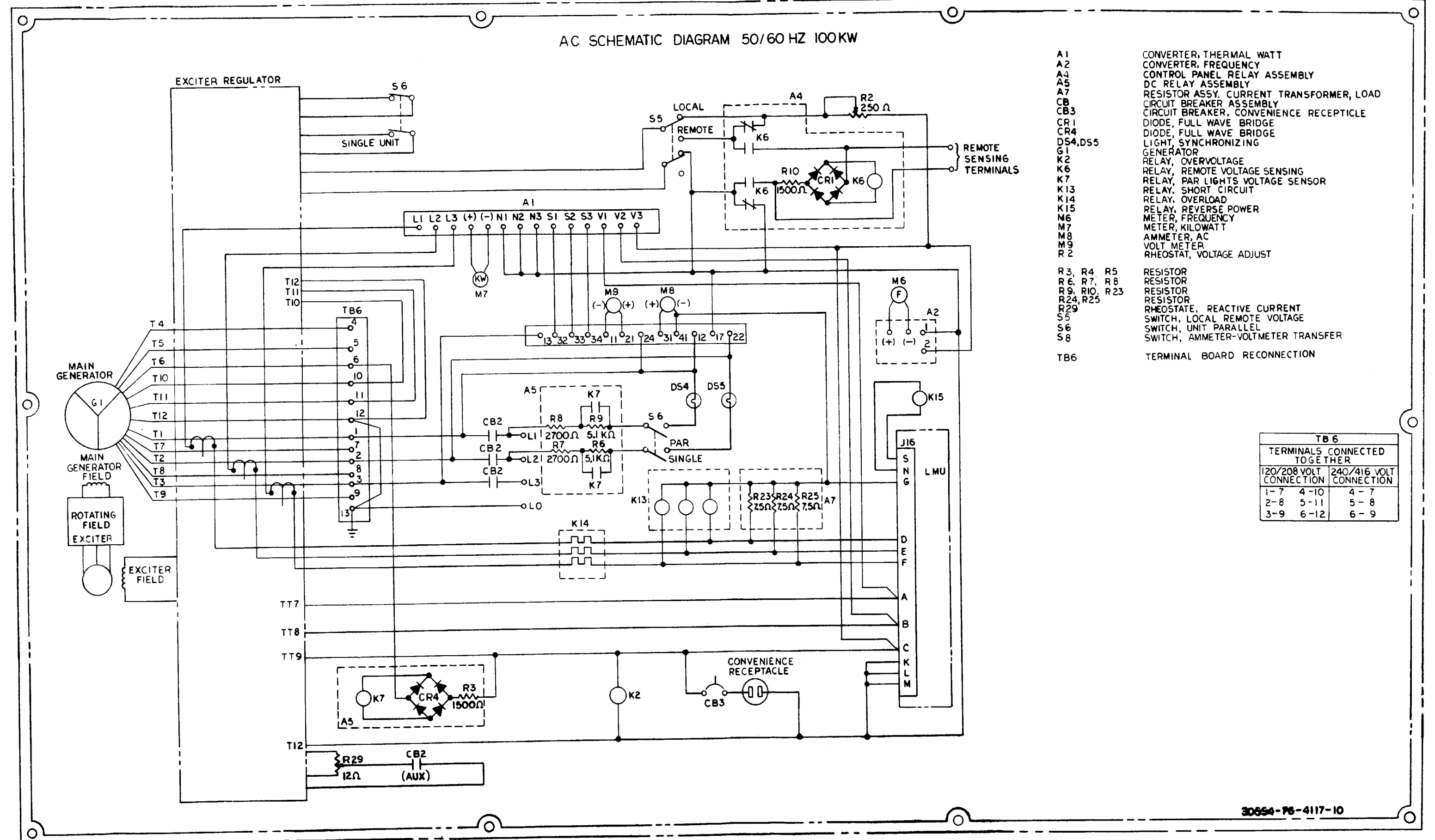

- A1 CONVERTER, THERMAL WATT
- A2 CONVERTER, FREQUENCY
- A3 CONTROL PANEL RELAY ASSEMBLY
- A5 DC RELAY ASSEMBLY
- A7 RESISTOR ASSY. CURRENT TRANSFORMER, LOAD
- CB3 CIRCUIT BREAKER ASSEMBLY
- CB2 CIRCUIT BREAKER, CONVENIENCE RECEPTACLE
- CR1 DIODE, FULL WAVE BRIDGE
- CR4 DIODE, FULL WAVE BRIDGE
- DS4, DS5 LIGHT, SYNCHRONIZING
- G1 GENERATOR
- K2 RELAY, OVERVOLTAGE
- K6 RELAY, REMOTE VOLTAGE SENSING
- K7 RELAY, PAR LIGHTS VOLTAGE SENSOR
- K13 RELAY, SHORT CIRCUIT
- K14 RELAY, OVERLOAD
- K15 RELAY, REVERSE POWER
- M6 METER, FREQUENCY
- M7 METER, KILOWATT
- M8 AMMETER, AC
- M9 VOLT METER
- R2 RHEOSTAT, VOLTAGE ADJUST
- R3, R4, R5 RESISTOR
- R6, R7, R8 RESISTOR
- R9, R10, R23 RESISTOR
- R24, R25 RESISTOR
- R29 RHEOSTATE, REACTIVE CURRENT
- S5 SWITCH, LOCAL REMOTE VOLTAGE
- S6 SWITCH, UNIT PARALLEL
- S8 SWITCH, AMMETER-VOLTMETER TRANSFER
- TB6 TERMINAL BOARD RECONNECTION

TB 6		
TERMINALS CONNECTED TOGETHER		
120/208 VOLT CONNECTION	240/416 VOLT CONNECTION	
1-7	4-10	4-7
2-8	5-11	5-8
3-9	6-12	6-9

30554-P6-4117-10

F0-4. AC Electrical System, Schematic Diagram



DC SCHEMATIC  
 DIAGRAM 50/60HZ  
 100KW

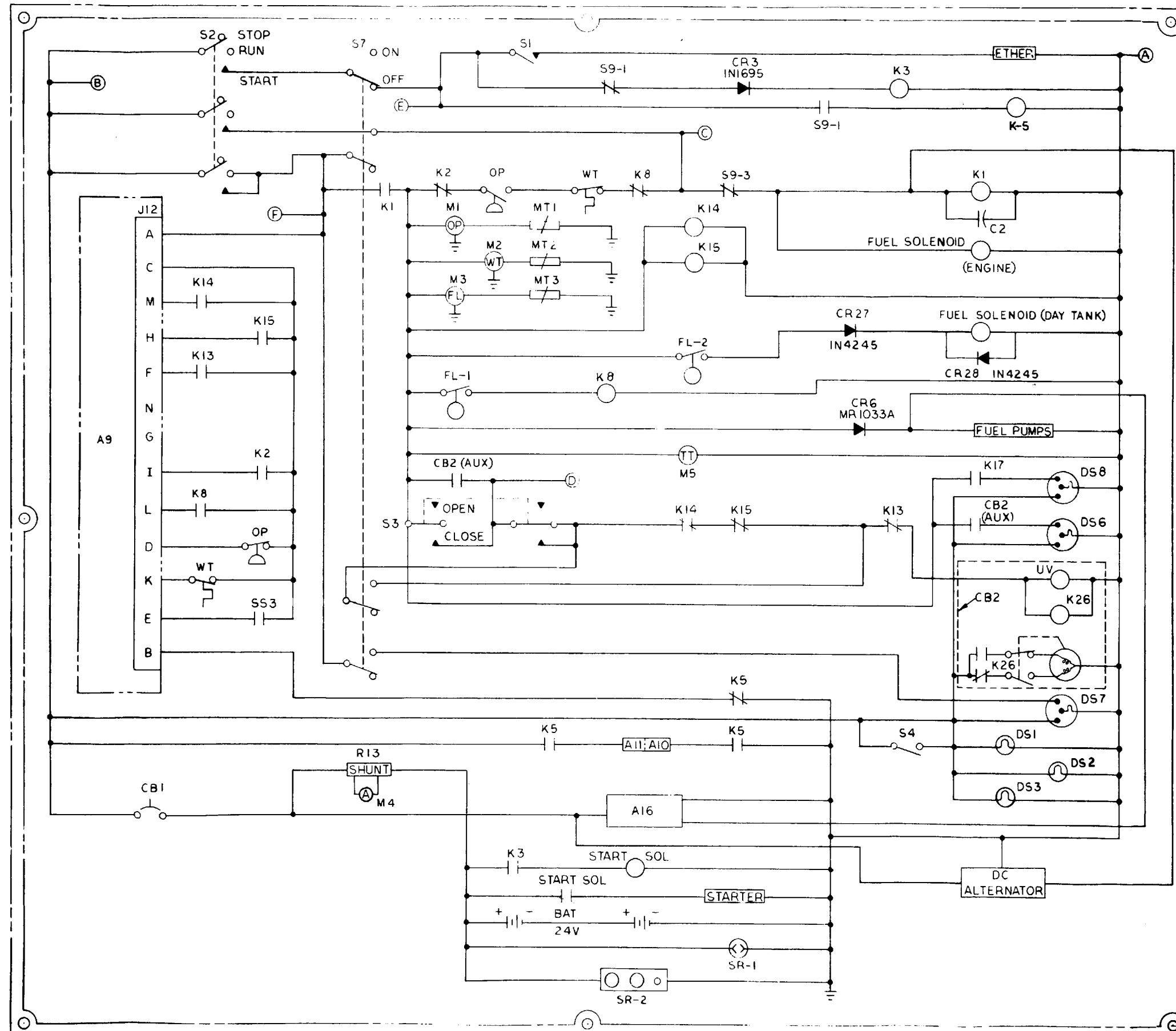

- A9 FAULT INDICATOR
- A10 VOLTAGE REGULATOR
- A11 EXCITER
- A16 HEATER CONTROL
- C2 CAPACITOR
- CB1 CIRCUIT BREAKER, DC
- CB2 CIRCUIT BREAKER ASSY.
- CR3, CR6 DIODE
- CR21, CR22 DIODE
- CR27, CR28 DIODE, RFI SUPPRESSION
- DS1, DS2, DS3 LIGHT, PANEL
- DS6 LIGHT, INDICATOR, CIRCUIT BREAKER
- DS7 LIGHT, PROTECTION BYPASS
- DS8 LIGHT, INDICATOR AIR CLEANER
- FL-1, FL-2 SWITCH, FUEL LEVEL
- K1 RELAY, STOP-RUN
- K2 RELAY, OVERVOLTAGE
- K3 RELAY, CRANK
- K5 RELAY, FIELD FLASH
- K8 RELAY, FUEL LEVEL
- K13 RELAY, SHORT CIRCUIT
- K14 RELAY, OVERLOAD
- K15 RELAY, REVERSE POWER
- K17 SWITCH, AIR CLEANER RESTRICTION
- K21, K21A RELAY, REMOTE START
- K22 RELAY, REMOTE STOP
- MT1 OIL PRESSURE SENDING UNIT
- MT2 WATER TEMPERATURE SENDING UNIT
- MT3 FUEL LEVEL SENDING UNIT
- M1 METER, OIL PRESSURE
- M2 METER, COOLANT TEMPERATURE
- M3 METER, FUEL LEVEL
- M4 AMMETER, BATTERY CHARGING
- M5 METER, TOTAL TIME
- OP SWITCH, OIL PRESSURE
- R13 SHUNT - M4
- R21, R22 RESISTOR
- SCR21 SILICON CONTROL RECTIFIER
- SR-1 RECEPTACLE, SLAVE
- SR-2 RECEPTACLE, SLAVE
- S9-1 START-DECONNECT AND FIELD FLASH
- S9-3 OVERSPEED
- S1 SWITCH, ENGINE PRIMER
- S2 SWITCH, START-RUN-STOP
- S3 SWITCH, CONTACTOR
- S4 SWITCH, PANEL LIGHTS
- S7 SWITCH, BATTLE-SHORT
- S20 SWITCH, REMOTE ON-OFF
- WT SWITCH, COOLANT TEMPERATURE

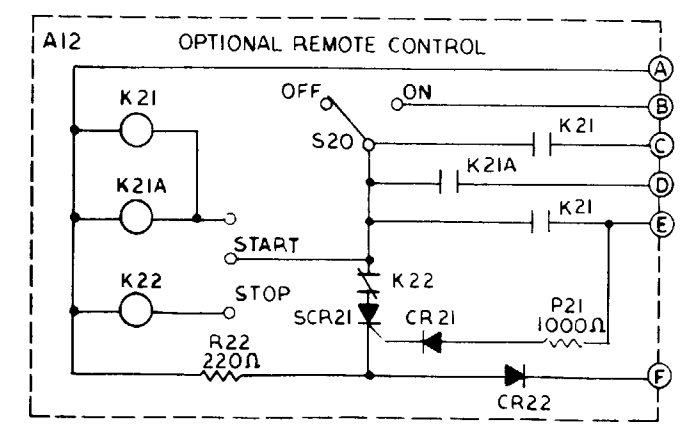

30554-76-4117-09

F0-5. DC Electrical System, Schematic Diagram



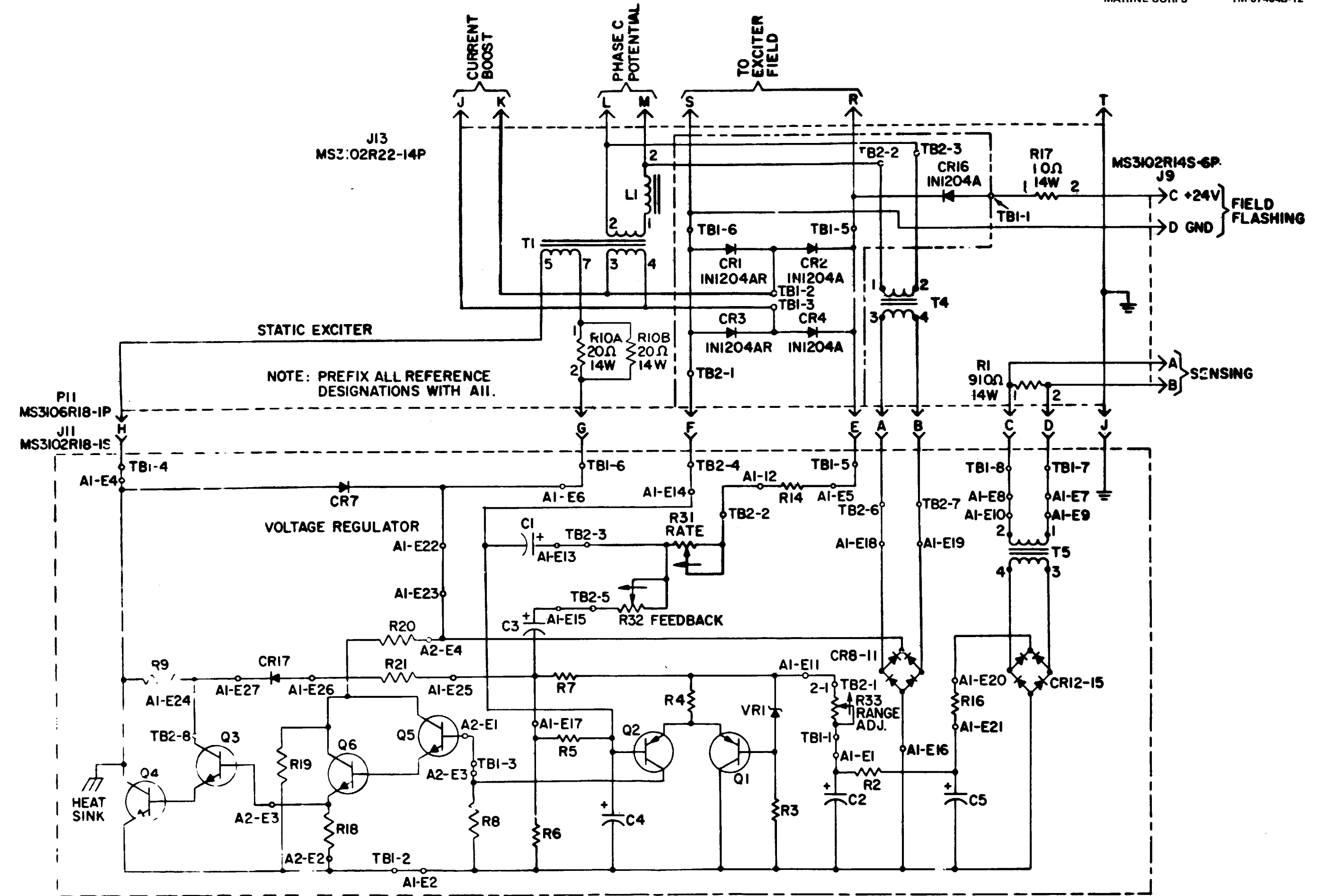

F0-6. Exciter-Regulator A11, Schematic Diagram







This fine document...

Was brought to you by me:



## [Liberated Manuals -- free army and government manuals](#)

Why do I do it? I am tired of sleazy CD-ROM sellers, who take publicly available information, slap “watermarks” and other junk on it, and sell it. Those masters of search engine manipulation make sure that their sites that sell free information, come up first in search engines. They did not create it... They did not even scan it... Why should they get your money? Why are not letting you give those free manuals to your friends?

I am setting this document FREE. This document was made by the US Government and is NOT protected by Copyright. Feel free to share, republish, sell and so on.

I am not asking you for donations, fees or handouts. If you can, please provide a link to [liberatedmanuals.com](http://liberatedmanuals.com), so that free manuals come up first in search engines:

<A HREF=<http://www.liberatedmanuals.com/>>Free Military and Government Manuals</A>

– Sincerely  
Igor Chudov  
<http://igor.chudov.com/>