

INCH-POUND

MIL-HDBK-633A  
26 January 2010  
SUPERSEDING  
MIL-HDBK-633  
20 February 1998

# DEPARTMENT OF DEFENSE HANDBOOK

## STANDARD FAMILY OF MOBILE ELECTRIC POWER GENERATING SOURCES

### GENERAL DESCRIPTION INFORMATION AND CHARACTERISTICS DATA SHEETS



**This handbook is for guidance only.  
Do not cite this document as a requirement.**

**AMSC N/A**

**FSC 6115**

## MIL-HDBK-633A

### FOREWORD

1. This handbook is approved for use by the Department and Agencies of the Department of Defense.
2. This Military Handbook provides information on standard mobile electric power sources for use by all Departments and Agencies of the Department of Defense (DoD).
3. Preparation of this document has been authorized by the Department of Defense Directive 4120.11, Standardization of Mobile Electric Power (MEP) Generating Sources, April 13, 2004, which assigns to the Project Manager, Mobile Electric Power the responsibility for establishing the Department of Defense (DoD) Standard Family of Mobile Electric Power Generating Sources (MEPGS). This MEP handbook revises the Standard Family by the deletion of Military Standard gasoline engine-driven generator sets, the addition of the 2 kW Military Tactical Generator (MTG), the MEP-501A (DC) and the MEP-531A (AC), and the replacement of the 3 kW - 60 kW Standard Family of Diesel Engine Driven (DED) models by Tactical Quiet Generators (TQG). These present and proposed MEPGS and their associated trailer mounted configurations are included in **APPENDIX A**. The Auxiliary Power Units (APU) MEP-952A and MEP-903A, which have been added to the Standard Family in accordance with guidance provided in SARD-ZCS Memorandum, are in **APPENDIX B**. The power distribution systems are in **APPENDIX C**.

The following are extracts from DoD Directive 4120.11: (Additional information on this policy can be found at: <http://www.dtic.mil/whs/directives/corres/pdf/412011p.pdf>).

#### “4. POLICY

4.1. It is DoD policy to:

4.1.1. Establish, maintain, and provide a DoD standard family of MEP generating Sources for maximum DoD Component use.

4.1.2. Implement the standardization policies of DoD Instruction 5000.2 (reference (b)) on MEP generating sources through the establishment of common military operational requirements, design and development, procurement, logistic support, and operational use by:

4.1.2.1. Planning and coordinating the DoD development, engineering, and product improvement efforts. The requirements will be satisfied to the maximum practicable extent through the use of nondevelopmental items, in accordance with Part 6, Section L of reference (b).

4.1.2.2. Ensuring the availability of standard MEP generating sources that will meet DoD-wide needs with the required electrical performance, reliability, maintainability, durability, and versatility by the most cost-effective means.

4.1.2.3. Reducing diversification of MEP generating sources entering the DoD supply system, thus minimizing logistic support without compromising mission accomplishment of the DoD Components.

4.1.2.4. Standardizing, to the maximum extent practicable, the electrical output characteristics of the MEP generating sources, consistent with military systems and equipment needs under MIL-HDBK-633 (reference (c)).”

#### 4. Fuel Standardization Policy

DoD Directive 4140.25, Subject: DoD Management Policy for Energy Commodities and Related Services establishes DoD bulk Petroleum Management Policy. The fuel standardization policy, paragraph 4.2 of the DOD Directive 4140.25, follows:

“4.2. Fuel Standardization. The Combatant Commanders shall develop plans to minimize the types of fuels required in joint operations. The Military Services shall design and

## MIL-HDBK-633A

procure weapon systems, support equipment, and vehicles. The Military Services will also qualify new systems to use readily available commercial-type fuels. Standard fuels approved by the Defense Standardization Program are listed in the Department of Defense Specifications and Standards under Federal Supply Group 91 listed in the ASSIST database. Primary fuel support for land-based air and ground forces in all theaters (overseas and in the Continental United States) shall be accomplished using a single kerosene-based fuel, in order of precedence: JP-8, commercial jet fuel (with additive package), or commercial jet fuel (without additives), as approved by the Combatant Commander. Fuel support for ground forces may also be accomplished using commercially available diesel fuel when supplying jet fuel is not practicable or cost effective. Primary fuel support for sea-based aircraft shall be a high-flash kerosene-based fuel, designated JP-5. In overseas theaters where the predominant fuel requirement is in support of the Navy, JP-5 may be substituted for JP-8, as approved by the Combatant Commander. Conventionally powered ships shall use a distillate-type fuel, designated F-76 for propulsion. Military Sealift ships may use commercial marine fuels for propulsion. The type of fuel designated for the battlefield shall be specified by the Combatant Commander depending on fuel availability and equipment to be used within the theater. To the maximum extent practical, no new combat support or combat service support equipment or vehicles requiring gasoline-type fuels shall be acquired or developed unless the support concept is to supply fuel as a packaged product.”

5. Beneficial comments (recommendations, additions, deletions) and any pertinent data, which may be of use in improving this document, should be addressed to DEPARTMENT OF THE ARMY, DOD PROJECT MANAGER - MOBILE ELECTRIC POWER, 5809 DELAFIELD ROAD BLDG 324, FORT BELVOIR, VA 22060-5809. Since contact information can change you may want to verify the currency of this address information using the ASSIST Online database at : <http://assist.daps.dla.mil>.

**MIL-HDBK-633A**

## TABLE OF CONTENT

**Paragraph**

	FOREWORD.....	ii
1.	SCOPE.....	1
1.1	General.....	1
1.2	Application.....	1
2.	APPLICABLE DOCUMENTS.....	1
2.1	General.....	1
2.2	Government documents.....	1
3.	DEFINITIONS.....	2
3.1	General.....	2
3.2	Acronyms used in this handbook.....	2
3.3	Accessory box.....	2
3.4	Bandwidth.....	2
3.5	Camouflage pattern.....	2
3.6	Classification.....	2
3.7	Deviation Factor.....	3
3.8	Dip.....	3
3.9	Failure.....	3
3.10	Harmonic.....	3
3.11	Hertz.....	3
3.12	Mean Time Between Failure (MTBF).....	3
3.13	Mobile Electric Power Generating Sources (MEPGS).....	3
3.14	Observed Steady-State Band.....	4
3.15	Overshoot.....	4
3.16	Paralleling.....	4
3.17	Phase Balance.....	4
3.18	Power Factor.....	4
3.19	Power Plant (PP).....	4
3.20	Power Unit (PU).....	4
3.21	Primary Inventory Control Activity (PICA).....	4
3.22	Rated load.....	4
3.23	Reconnectable.....	4
3.24	Recovery Time.....	4
3.25	Regulation.....	4
3.26	Ripple Voltage.....	4
3.27	Rise.....	4
3.28	Stability.....	4

**MIL-HDBK-633A**

3.29	<i>Steady-State</i> .....	5
3.30	Type Classified for Army Use .....	5
3.31	Undershoot .....	5
3.32	Voltage Modulation .....	5
4.	GENERAL REQUIREMENTS .....	5
4.1	Safety .....	5
4.2	Delivered condition .....	5
5.	DETAILED REQUIREMENTS .....	6
5.1	Data Sheets .....	6
6.	ITEMS OF NOTE .....	7
6.1	Purpose .....	7
6.2	Supersession Data .....	7
6.3	National Stock Numbers (NSN) .....	7
6.4	MEPGS Program Status .....	7
6.5	Mobile Electric Power Generating Source Development Program. ....	7
6.6	Items not Army Type-Classified .....	7
6.7	Cross reference .....	7
6.8	Subject term (key word) listing .....	7
	APPENDIX A .....	11
A.1	SCOPE .....	11
A.2	APPLICABLE DOCUMENTS .....	12
A.3	DEFINITIONS .....	12
A.4	GENERAL DESCRIPTIONS .....	12
A.5	DETAILED DESCRIPTIONS .....	14
	APPENDIX B .....	67
B.1	SCOPE .....	67
B.2	APPLICABLE DOCUMENTS .....	67
B.3	DEFINITIONS .....	67
B.4	GENERAL DESCRIPTIONS .....	67
B.5	DETAILED DESCRIPTIONS .....	67
	APPENDIX C .....	73
C.1	SCOPE .....	73
C.2	APPLICABLE DOCUMENTS .....	73
C.3	DEFINITIONS .....	73
C.4	GENERAL DESCRIPTIONS .....	73
C.5	DETAILED DESCRIPTIONS .....	73

**MIL-HDBK-633A**

APPENDIX D	81
D.1. SCOPE .....	81
D.2. APPLICABLE DOCUMENTS.....	81
D.3. DEFINITIONS Acronyms used in this Appendix:.....	81
D.4. GENERAL DESCRIPTIONS.....	81
D.5. DETAILED DESCRIPTIONS .....	83
APPENDIX E	95
E.1 SCOPE .....	95
E.2 APPLICABLE DOCUMENTS.....	96
E.3 DEFINITIONS .....	96
E.4 GENERAL DESCRIPTION .....	96
E.5 DETAILED DESCRIPTIONS .....	97

**Tables**

Table I Cross Reference by Generator Size .....	8
Table II Cross Reference ordered by model number.....	9
Table A- I Guide to CHARACTERISTICS DATA SHEETS of APPENDIX A.....	11
Table A- II Batteries and Auxiliary Equipment.....	13
Table B- I Guide to CHARACTERISTICS DATA SHEETS of APPENDIX B.....	67
Table C- I Guide to CHARACTERISTICS DATA SHEETS of APPENDIX C.....	73
Table D- I. Guide to CHARACTERISTICS DATA SHEETS of APPENDIX D.....	81
Table D- II Some PDISE - generator applications .....	91
Table D- III Approximate voltage losses at rated amperage* .....	91
Table D- IV Auxiliary equipment .....	92
Table D- V Connector to phase links .....	93
Table D- VI Common characteristics of PDISE/DISE .....	93
Table E- I Guide to CHARACTERISTICS DATA SHEETS of APPENDIX E	95

**Figures**

Figures A to C For Characteristic Data sheets (figures) see TABLE I

Figure 1 Auxiliary Fuel Line.....	6
Figure D- 1 Power Distribution and Illumination System, Electrical (PDISE) Family	81
Figure D- 2 200 Amp per Phase Feeder System - 3 Phase .....	84
Figure D- 3 100 Amp per Phase Feeder System - 3 Phase .....	85
Figure D- 4 40 Amp per Phase Distribution System - 3 Phase.....	86
Figure D- 5 60 Amp Distribution System - 1 Phase .....	87
Figure D- 6 Utility Receptacles and Lighting Set .....	88

**MIL-HDBK-633A**

Figure D- 7 Sample of a possible distribution arrangement..... 89  
Figure D- 8 Universal Adapter ..... 90

**MIL-HDBK-633A**

This Page Intentionally Left Blank



**MIL-HDBK-633A****1. SCOPE**

1.1 General. This handbook provides detailed information on the physical and electrical characteristics and logistical data on the DoD approved Standard Family of Mobile Electric Power Generating Sources. This handbook is a catalog of all PM-MEP mobile power source products for use by all Departments and Agencies of the DoD. This handbook is for guidance only and cannot be cited as a requirement.

1.2 Application. The handbook has been prepared for use by all Departments and Agencies of the DoD in selecting engine-driven generator sets and ancillary equipment for applications requiring mobile sources of electric power and to assist the Project Manager, Mobile Electric Power (PM-MEP) in effecting management and standardization of such sources of power within the DoD. The engine-driven generator sets listed herein are the only mobile sets authorized for procurement. DoD components with mobile electric power requirements within the range of 0.5 kW through 1.1 megawatt, whose needs cannot be satisfied by one of the listed generator sets, must obtain deviation approval from the PM-MEP before taking any procurement action. Special instructions on the preparation and submittal of deviations are contained in the Logistics Joint Operating Procedures AR 700-101, AFI 63-110(I), NAVFACINST 4120.12, MCO 11310.8C, DLAR 4120.16 titled Management and Standardization of Mobile Electric Power Generating Sources. Online versions are available at: [http://www.apd.army.mil/pdffiles/r700\\_101.pdf](http://www.apd.army.mil/pdffiles/r700_101.pdf).

**2. APPLICABLE DOCUMENTS**

2.1 General. The documents listed below are not necessarily all of the documents referenced herein, but are the ones necessary to understand the information provided by this handbook.

**2.2 Government documents.**

2.2.1 Specifications and standards. The following specifications and standards form a part of this document to the extent referenced herein. Copies of these documents are available online at <http://assist.daps.dla.mil/quicksearch/> or from the Standardization Document Order Desk, 700 Robbins Avenue, building 4D Philadelphia, PA 19111-5094.

**DEPARTMENT OF DEFENSE****STANDARDS**

MIL-STD-461	REQUIREMENTS FOR THE CONTROL OF ELECTROMAGNETIC INTERFERENCE CHARACTERISTICS OF SUBSYSTEMS AND EQUIPMENT
MIL-STD-705	GENERATOR SETS, ENGINE-DRIVEN, METHODS OF TESTS AND INSTRUCTIONS
MIL-STD-1332	DEFINITIONS OF TACTICAL, PRIME, PRECISE AND UTILITY TERMINOLOGIES FOR CLASSIFICATION OF THE DOD MOBILE ELECTRIC POWER ENGINE GENERATOR SET FAMILY

**SPECIFICATIONS**

MIL-DTL-53072	CHEMICAL AGENT RESISTANT COATING (CARC) SYSTEM APPLICATION PROCEDURES AND QUALITY CONTROL INSPECTION
MIL-DTL-22992	CONNECTORS, PLUGS AND RECEPTACLES, ELECTRICAL, WATERPROOF, QUICK DISCONNECT, HEAVY DUTY TYPE

**MIL-HDBK-633A**

2.2.2 Other Government publications. The following other Government publication forms a part of this document to the extent specified herein. This document can be downloaded at the following link: <http://www.globalsecurity.org/military/library/policy/army/fm/5-424/index.html>.

ARMY FIELD MANUALS

FM 5-424

THEATER OF OPERATIONS ELECTRICAL MANUALS

### 3. DEFINITIONS

3.1 General. The following acronyms and definitions are used in this handbook .

3.2 Acronyms used in this handbook . Defined acronyms follow:

- a. ABCA - American, British, Canadian, Australian (Quadripartite subset of NATO).
- b. DED - Diesel Engine Driven.
- c. DoD - Department of Defense.
- d. DSN - Defense Switched Network (formerly AUTOVON). A military telephone system.
- e. MTBEFF – Mean Time Between Essential Function Failure.
- f. GED - Gasoline Engine Driven.
- g. GS - General Support.
- h. GTED - Gas Turbine Engine Driven.
- i. LIN - Line Item Number. A six character identifier of a generic nomenclature, where the generic nomenclature is the family name of an item or group of items whose physical traits and functional abilities are sufficiently alike to be issued to meet the same operational requirements. A LIN generally includes several National Stock Numbers.
- j. NATO - North Atlantic Treaty Organization.
- k. NSN - National Stock Number. A unique identifier for stocking an item.
- l. OEM - On Equipment Material.
- m. PICA - Primary Inventory Control Activity. See 3.21
- n. PU/PP - Power Unit/Power Plant. See 3.19 and 3.20.
- o. RMS - Root Mean Square. An averaging method. For a sine wave  $RMS = .707 \text{ Peak}$ .
- p. SSN - Standard Study Number. A federal budget identifier for procuring an item.
- q. STANAG - Standardization Agreement (of NATO).
- r. QSTAG - Quadripartite Standardization Agreement (of ABCA).

3.3 Accessory box. An accessory box is an aluminum or steel box mounted to the PU/PP trailer which contains items necessary for the set-up, operation, or maintenance of the unit. These items include: ground rods, a sledge hammer or ground rod driver/puller, technical manuals and fuel can adapters, which are referred to as ancillary equipment.

3.4 Bandwidth. Bandwidth is the distance between two lines drawn parallel to the axis of chart movement, one each passing through the center points of maximum and minimum trace excursion respectively during any steady-state electrical load condition. Bandwidth may refer to voltage, frequency or speed and is expressed as a percentage of rated voltage, frequency or speed.

3.5 Camouflage pattern. A three-color pattern designed to disrupt the silhouette or outline of a piece of equipment making it difficult to distinguish the equipment from its surroundings.

3.6 Classification. See MIL-STD-1332 for classification of sets as to type, class, and mode.

**MIL-HDBK-633A**

3.7 Deviation Factor. The deviation factor of a voltage waveform is the ratio of the maximum difference between corresponding ordinates of the voltage waveform and of the equivalent sine wave to the maximum ordinate of the equivalent sine wave when the waves are superimposed in such a way as to make this maximum difference as small as possible.

3.8 Dip. Voltage dip is the decrease in voltage resulting from sudden application of load to a generator set. It is measured from the mean of the observed steady-state voltage band prior to the load change to the minimum voltage excursion. Voltage dip includes the effects of voltage regulation, whereas undershoot does not.

3.9 Failure. The inability of an item to perform within previously specified limits.

3.9.1 Relevant Failure. A relevant failure is any malfunction the operator cannot remedy by normal adjustment action using the set controls and equipment and which causes or may cause any or all of the following: inability to commence operation, cessation of operation or degradation of performance capability of the system/subsystem below designated levels, serious damage to system/subsystem by continued operation; or serious personnel hazard.

3.9.2 Non-relevant Failures. Any failure not used to compute set/unit reliability such as:

- a. Failures which do not prevent the set/unit from meeting the specified power output requirement, e.g., a panel light burns out.
- b. Failures caused by operator error where proper procedures are documented in technical manuals, instruction plates mounted on the set/unit or both; e.g., use of improper lubricant.
- c. Secondary failures caused by failures in the powered equipment or other occurrences in the environment when integral protection is not provided against such equipment failure or occurrence, e.g., explosion or fire.
- d. Failures which may be corrected by normal operator functions, e.g., readjustment of voltage after the 4-hour long-term stability period.
- e. Failures because of characteristics of the load, e.g., waveform distortion caused by saturated inductors.
- f. Failures because of design deficiencies when subsequent testing demonstrates that the design deficiency has been corrected.
- g. Secondary failures caused by primary failure because of a design deficiency when subsequent testing demonstrates that the design deficiency has been corrected.
- h. Failures resulting from operating items beyond requirements, e.g., if ball joints scheduled for replacement at 2500 hours are run to failure to determine mean life, failures after 2500 hours are non-relevant failures.

3.10 Harmonic. A harmonic is a component of a periodic quantity which is an integral multiple of the fundamental frequency. For example, a component of frequency which is twice the fundamental frequency is called the second harmonic. For an AC generator set, the magnitudes (in percent of fundamental component amplitude) of any harmonics present may not exceed the "individual harmonic" value specified for the set.

3.11 Hertz. Hertz (Hz) is the international unit of frequency.

3.12 Mean Time Between Failure (MTBF). For exponentially distributed failures, the Mean Time Between Failure (MTBF) is the reciprocal of the failure rate. Observed MTBF is equal to the total operating time of the equipment divided by the number of relevant failures. Observed MTBF is a point estimate. Upper and lower confidence limits can be established for a given test plan.

3.13 Mobile Electric Power Generating Sources (MEPGS). All mobile, electric power generating sources, 920-kilowatt (kW) and smaller, which are skid mounted, wheel mounted, or man-portable that are complete equipment assemblages or part of an assemblage, and that are capable of independently producing electric power when operating on diesel, gasoline, or other fuel from integral or remotely located fuel sources. MEPGS that have been incorporated into the DoD Standard Family are identified in this military handbook .

**MIL-HDBK-633A**

3.14 Observed Steady-State Band. The observed steady-state band is the actual bandwidth determined by test of the voltage, frequency or speed. The observed steady-state band is differentiated from the prescribed steady-state band in that the prescribed steady-state band is the maximum bandwidth permitted by the specification.

3.15 Overshoot. Overshoot is the surge increase in speed, frequency or voltage above the mean of the observed steady-state band resulting from a sudden decrease in electrical load on a generator set. Overshoot is specified as a percentage of the rated speed, frequency or voltage.

3.16 Paralleling. The electrical connection of two or more electrical power generating sources in order to meet a power demand greater than that supplied by any single unit.

3.17 Phase Balance Voltage. Phase balance voltage is the difference in percent of voltage between the phases of a multi-phase generator set when the set is operating at rated voltage, rated frequency, and no load.

3.18 Power Factor. The power factor is a ratio, between zero and one, used to correct the apparent power (volts x amps) to the actual power. A phase difference between the voltage and the current, caused by capacitive and/or inductive loads, reduces the power consumption since the peak voltage no longer multiplies the peak current and vice versa.

3.19 Power Plant (PP). A trailer mounted generator set configuration consisting of two generator sets, one or two trailers, a switch box and usually an accessory box (with hammer, ground rods, and puller) and a fire extinguisher on each trailer. Details are provided in Characteristics Sheet.

3.20 Power Unit (PU). A trailer mounted generator set configuration consisting of one generator set, one trailer and usually an accessory box (with hammer, ground rods, and puller) and a fire extinguisher. Details are provided in Characteristics Sheet.

3.21 Primary Inventory Control Activity (PICA). The activity within DoD designated as responsible for the functions of procurement, cataloging, depot maintenance, and disposal on an item basis.

3.22 Rated load. The condition resulting when a generator set is operating at rated frequency, rated voltage, rated current, and rated power factor as specified on the generator name plate. It is normally stated as a given kilowatt value at a given power factor.

3.23 Reconnectable. A reconnectable generator set has provisions for reconnecting the generator phase windings from single phase to three phase and from low voltage to high voltage depending on the size and type of generator set.

3.24 Recovery Time. Recovery time is the elapsed time from the time the frequency trace leaves the prescribed steady-state band until the trace returns to and remains within the prescribed steady-state band as a result of a load change. The same definition applies to voltage and frequency recovery time.

3.25 Regulation. Frequency regulation is the maximum difference between the no-load value of frequency, and the value at any load up to and including rated load. This difference is expressed as percentage of the rated frequency. The voltage regulation is expressed similarly except that the Root Mean Square (RMS) value of voltage is used.

3.26 Ripple Voltage. Ripple voltage is the alternating component in the output voltage of a DC generator.

3.27 Rise. Voltage rise is the surge in voltage resulting from sudden removal of load from a generator set. It is measured from the mean of the observed steady-state voltage band prior to the load change to maximum voltage excursion. Voltage rise includes the effects of voltage regulation, whereas overshoot does not.

3.28 Stability. Frequency stability describes the tendency of the frequency to remain at a constant value. Generally, the instantaneous value of frequency is not constant but varies randomly above and below a mean value. Stability may be described as either short-term or long term depending upon the length of time that the frequency is observed. Another term, bandwidth, describes the limits of these variations. Voltage stability is described similarly.

**MIL-HDBK-633A**

3.29 Steady-State. Steady-state is the operating condition, at constant load, after transients have settled out.

3.30 Type Classified for Army Use. Type Classification (TC) is a process by which the Army identifies the degree of acceptability of a material item for Army use. The TC is the Army's implementation of the DoD requirement that an item is "approved for service use" before expending procurement funds. The types of classification categories are: Limited Procurement (LP), Standard (STD), and Generic.

3.31 Undershoot. Undershoot is the surge decrease in speed, frequency, or voltage below the mean of the observed steady-state band resulting from a sudden increase in electrical load on a generator set. Undershoot is specified as a percentage of the rated speed, frequency, or voltage.

3.32 Voltage Modulation: The peak value of a voltage waveform may vary with time. Voltage modulation is the difference in the absolute value of the peak voltage readings stated as a percentage of average absolute peak voltage.

#### 4. GENERAL REQUIREMENTS

##### 4.1 Safety.

4.1.1 Grounding. Electrical power generating and distribution systems must be properly grounded to prevent hazards to operators and using personnel. Techniques for grounding power generating systems are included in FM 5-424, Electric Power Generation in the Field. A three-piece sectional ground rod is available in the DoD supply system that can be used to obtain an adequate ground under most soil conditions.

4.1.2 Fire Protection. Adequate fire protection must be provided in the area in which the generator set will be used. Fire extinguisher, NSN: 4210-00-270-4512, is recommended.

4.1.3 Noise Protection. Adequate hearing protection must be utilized in the vicinity of most operating generator sets. Prolonged exposure to the high intensity noise produced by some operating generator sets can cause permanent hearing damage or complete loss of hearing. Operation of the TQG and other quiet generators does not require hearing protection as long as the acoustic covers are not opened or removed.

4.2 Delivered condition. Details of delivered condition, operating supplies, optional equipment, and accessories are contained in the applicable Appendix. Trailer mounted configurations are delivered with more accessories including the fire extinguisher and an additional set of ground rods.

4.2.1 Camouflage Patterns. Most items covered by this handbook are delivered with either a three color (green, brown, black) camouflage pattern or painted desert sand, as required. Some exceptions exist and some items may be painted a solid green while other items may be painted flight line yellow.

4.2.2 Chemical Agent Resistant Coating (CARC). Chemical Agent Resistant Coating (CARC), applied in accordance with MIL-DTL-53072, is the finish now required for all Army equipment. CARC, a polyurethane finish, is designed to be resistant to Nuclear, Biological, and Chemical (NBC) agents and allow easy clean up and decontamination. In addition, CARC will not be affected by the chemical agent decontamination chemicals which would remove most other paints.

##### 4.2.3 Skid sets.

a. Safety Items. Production generator sets may or may not be delivered with fire extinguishers, ground rods or ground rod slide hammer/puller. Units may obtain a 5 pound carbon dioxide fire extinguisher (NSN 4210-00-270-4512), 3-foot-sections of ground rod (NSN 5975-00-878-3791) and a ground rod slide hammer/puller (NSN 5120-01-013-1676).

b. Batteries. All 3 kW through 840 kW generator sets use Optima batteries. The 2 kW set has no battery and is rope started and also has a starting motor powered through a NATO slave receptacle. The 100 and 200 kW TQG sets use 12V starved electrolyte batteries.

c. Auxiliary Fuel Line. A 25 foot auxiliary fuel line is furnished with the 5 kW through 200 kW diesel engine driven generator sets. Fuel lines for the other sets may be ordered or fabricated on site in accordance with drawing 69-668, titled, Auxiliary Fuel Line, see Figure 1.

MIL-HDBK-633A

d. Ether starting aid. The 15 kW through 200 kW diesel engine driven generator sets may be equipped with an internal ether starting aid for temperatures below 40 °F. Ether bottles may be obtained as NSN 2910-00-209-4997.

e. Paralleling cables. Paralleling cables are provided with sets sizes 15 through 750 kW. Sets can only be paralleled to the same model.

f. Power output terminals. Power output terminals consist of split-lug terminals with captive nuts. A series of standard power output receptacles (MIL-DTL-22992) are available through the supply system. The Power Distribution and Illumination System, Electrical (PDISE) interfaces to the power output terminals via a pigtail connection. The old 15-200 kW DoD generator sets have two (2) panels that can be used for mounting the standard receptacles needed by the user.

4.2.4 Trailer mounted sets. The trailer mounted sets (Power Units and Power Plants (PUPP)) are delivered with one or more fire extinguishers, ground rods, ground rod driver/puller, and 8 pound hammer. Several trailers are used in Power Unit and Power Plant configurations. Details have been included in the appropriate appendices.

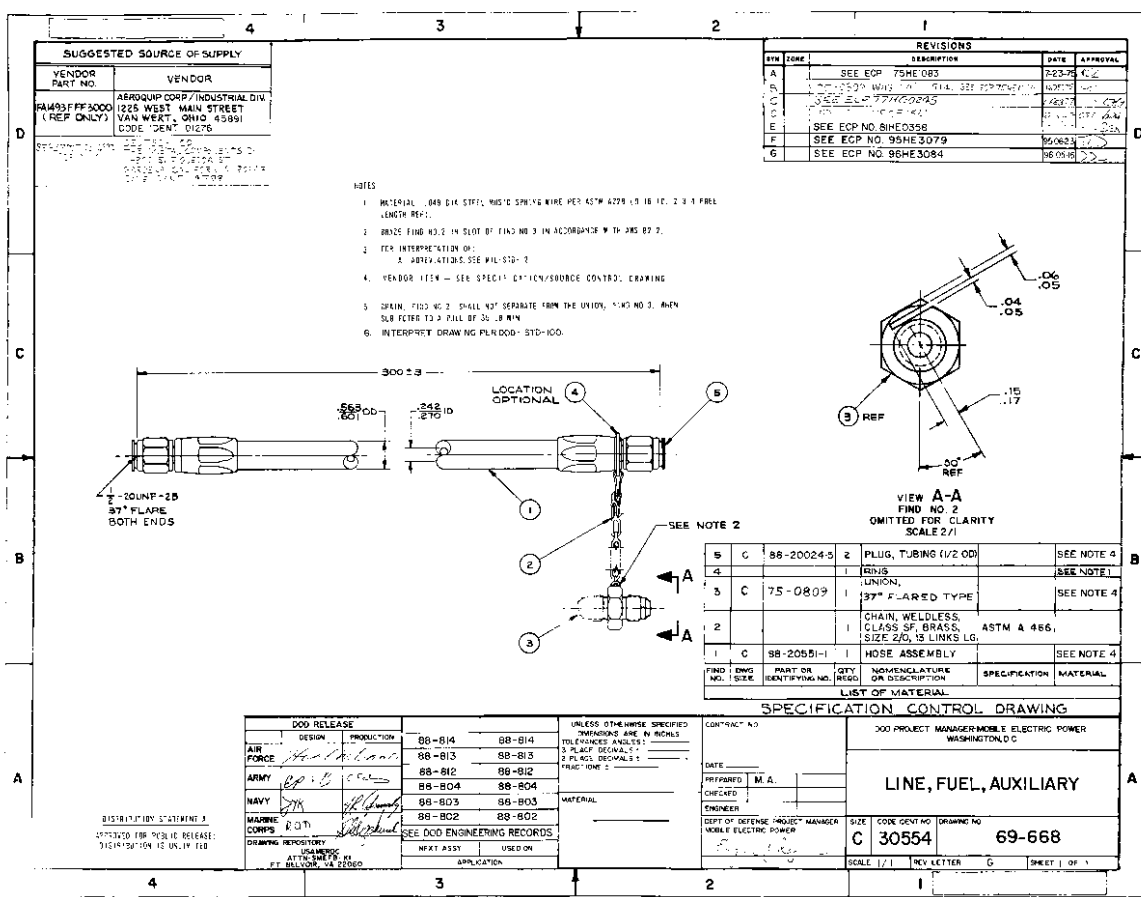

Figure 1 Auxiliary Fuel Line

5. DETAILED REQUIREMENTS.

5.1 Data Sheets. Detailed data on DoD standard family engine generator sets and associated items are contained in the Data Sheets of APPENDIX A through APPENDIX C.

5.1.1 Item Description. Data contained in the sheets provide adequate physical description and performance characteristics to permit selection of the item best suited for a specific application. In addition, photographs and outlined drawings are included to facilitate application planning.

**MIL-HDBK-633A**

5.1.2 Parametric Values. The parametric values cited within these data sheets are the maximum allowable limits over the specified environmental range. Specified parametric values were determined using the test procedures delineated in MIL-STD-705, Generator Sets, Engine-Driven, Methods of Tests and Instructions. For a more complete description, see applicable specifications, drawings, and referenced documents.

## 6. ITEMS OF NOTE

6.1 Purpose. This military handbook is a catalog of PM-MEP products. This document is not to be used for procurement purposes.

6.2 Supersession Data: MIL-HDBK-633A supersedes MIL-HDBK-633.

6.3 National Stock Numbers (NSN). National Stock Numbers for mobile electric power generator sets and associated equipment are provided in [Tables: I, II, A-I, B-I and C-I](#), and in the individual data sheets.

6.4 MEPGS Program Status. Current information on the DoD MEPGS program is available on the PM-MEP website: <http://www.pm-mep.army.mil>. To determine the availability of desired generator sets or associated equipment and to assure proper and timely acquisition of MEPGS, users of this handbook are advised to contact PM-MEP at:

Project Manager - Mobile Electric Power  
5850 Delafield Road, Bldg 324  
Fort Belvoir, Virginia 22060-5809  
Phone: (703)704-3162, DSN: 654-3162  
Fax:(703)704-3257, DSN: 654-3257  
Website: <http://www.pm-mep.army.mil>  
Email: See website

6.5 Mobile Electric Power Generating Source Development Program. A Mobile Electric Power Generating Source (MEPGS) development program is managed by the DoD Project Manager - Mobile Electric Power. The Advanced Medium Mobile Power Sources (AMMPS) program, which covers power sources in the 5 to 60 kW range, is presently in development. This program, which utilizes emerging and innovating technology, is expected to produce quieter, more efficient and lighter weight generator set in the FY 2011-2013 timeframe. If users of this handbook cannot find a suitable generator set within the DoD Mobile Electric Power Engine-Driven Generator Standard Family as presented in this Handbook, they are advised to contact the PM-MEP (see Para 6.4). The PM-MEP office can obtain status of any development program(s) and determine if a suitable power source will be available when needed.

6.6 Items not Army Type-Classified. Army Type-Classification (see 3.30) is a procedure described by AR 70-1 to designate Army materiel acquisition status. Some mobile electric power generating sources included in this document have not been Type-Classified for Army use and are identified by "Not Type-Classified for Army Use." These items have been approved for use by another service. Other items, such as the Auxiliary Power Units (APUs), have been Army type-classified as part of a larger system and are not separately fielded. These items are identified by "Not Separately Type-Classified."

6.7 Cross reference. Table I provides a cross reference of the figure numbers to the model number, item descriptions, NSN, LIN, SSN, and page number. Table I is listed by generator size within the three appendices. Table II provides this information ordered by model number.

6.8 Subject term (key word) listing.

Auxiliary Power  
Generator  
Generator set  
Power Plant  
Power Unit  
Power Distribution

## MIL-HDBK-633A

Table I Cross Reference by Generator Size

FIG	MODEL	ITEM DESCRIPTION	NSN	LIN	SSN	Page
Figure A-1	MEP-501A	2 kW MTG, 28 VDC, DED, Tubular Frame	6115-01-435-1567	G36169	M59400	16
Figure A-1	MEP-501A	2 kW MTG, 28 VDC, DED (First Buy)	6115-21-912-0392	G36169	M59400	16
Figure A-1	MEP-531A	2 kW MTG, 60 Hz, DED, Tubular Frame	6115-01-435-1565	G36237	M59400	16
Figure A-1	MEP-531A	2 kW MTG, 60 Hz, DED (First Buy)	6115-21-912-0393	G36237	M59400	16
Figure A-2	MEP-831A	3 kW TQG, 60 Hz, DED, Skid Mtd	6115-01-285-3012	G18358	M59400	18
Figure A-2	MEP-832A	3 kW TQG, 400 Hz, DED, Skid Mtd	6115-01-287-2431	G74847	M59400	18
Figure A-3	PP-AN/MJQ-42	3 kW TQ Power Plant, 60 Hz, TRLMTD	6115-01-322-8583	Z13645	R62700	21
Figure A-4	PP-AN/MJQ-43/43A	3 kW TQ Power Plant, 60 Hz, TRLMTD	6115-01-322-8582	Z13713	R62700	21
Figure A-5	MEP-802A	5 kW TQG, 60 Hz, DED, Skid Mtd	6115-01-274-7387	G11966	M53500	22
Figure A-5	MEP-812A	5 kW TQG, 400 Hz, DED, Skid Mtd	6115-01-274-7391	G12102	M53500	22
Figure A-6	PU-797A	5 kW TQ Power Unit, 60 Hz, TRLMTD	6115-01-413-3820	G42238	R62700	24
Figure A-7	PP-AN/MJQ-35A	5 kW TQ Power Plant, 60 Hz TRLMTD	6115-01-414-9697	P28083	R62700	25
Figure A-8	PP-AN/MJQ-36	5 kW TQ Power Plant, 60 Hz TRLMTD	6115-01-313-4215	P28151	R62700	26
Figure A-9	MEP-803A	10 kW TQG, 60 Hz, DED, Skid Mtd	6115-01-275-5061	G74711	M53500	27
Figure A-9	MEP-813A	10 kW TQG, 400 Hz, DED, Skid Mtd	6115-01-274-7392	G74779	M53500	27
Figure A-10	PU-798A	10 kW TQ Power Unit, 60 Hz, TRLMTD	6115-01-413-3818	G42170	R62700	30
Figure A-11	PU-799A	10 kW TQ Power Unit, 400 Hz, TRLMTD	6115-01-413-3819	G53403	R62700	31
Figure A-12	PP-AN/MJQ-37	10 kW TQ Power Plant, 60 Hz, TRLMTD	6115-01-299-6035	P42262	R62700	32
Figure A-13	PP-AN/MJQ-38	10 kW TQ Power Plant, 400 Hz, TRLMTD	6115-01-313-4214	P42330	R62700	33
Figure A-14	MEP-804B	15 kW TQG, 50/60 Hz, DED, Skid Mtd	6115-01-530-1458	G12170	M53500	34
Figure A-14	MEP-814B	15 kW TQG, 400 Hz, DED, Skid Mtd	6115-01-529-9494	G12238	M53500	34
Figure A-15	PU-800A	15 kW TQ Power Unit, 400 Hz, TRLMTD	6115-01-565-0929	G78203	R62700	36
Figure A-16	PU-801B	15 kW TQ Power Unit, 50/60 Hz, TRLMTD	6115-01-565-0874	G78374	R62700	37
Figure A-17	PU-802A	15 kW TQ Power Unit, 50/60 Hz, TRLMTD	6115-01-565-1576	G53778	R62700	38
Figure A-18	PP-AN/MJQ-39B	15 kW TQ Power Unit, 400 Hz, TRLMTD	6115-01-565-0701	P42614	R62700	39
Figure A-19	PP-AN/MJQ-48B	15 kW TQ Power Unit, 50/60 Hz, TRLMTD	6115-01-565-0691	Z01012	R62700	40
Figure A-20	MEP-805B	30 kW TQG, 50/60 Hz, DED, Skid Mtd	6115-01-461-9335	G74575	M53500	41
Figure A-20	MEP-815B	30 kW TQG, 400 Hz, DED, Skid Mtd	6115-01-462-0290	G74643	M53500	41
Figure A-21	PU-803B	30 kW TQ Power Unit, 50/60 Hz, TRLMTD	6115-01-470-6376	G35851	R62700	44
Figure A-22	PU-804B	30 kW TQ Power Unit, 400 Hz, TRLMTD	6115-01-471-1507	G35919	R62700	45
Figure A-23	PP-AN/MJQ-40B	30 kW TQ Power Plant, 50/60 Hz TRLMTD	6115-01-474-3783	P42126	R62700	46
Figure A-24	MEP-806B	60 kW TQG, 50/60 Hz, DED, Skid Mtd	6115-01-462-0291	G12034	M53500	47
Figure A-24	MEP-816B	60 kW TQG, 400 Hz, DED, Skid Mtd	6115-01-462-0292	G18052	M53500	47
Figure A-25	PU-805B	60 kW TQ Power Unit, 50/60 Hz, TRLMTD	6115-01-471-1508	G78306	R62700	50
Figure A-26	PU-806B	60 kW TQ Power Unit, 400 Hz, TRLMTD	6115-01-471-1506	G17406	R62700	51
Figure A-27	PP-AN/MJQ-41B	60 kW TQ Power Plant, 50/60 Hz, TRLMTD	6115-01-474-3776	P42194	R62700	52
Figure A- 28	PP-AN.MJQ-1612	Power Plant, TQG, 60 kW, 400 Hz, TRLMTD	6115-01-349-1536		M510	42
Figure A- 29	PP-AN/MJQ-1632	Power Plant, TQG, 60 kW, 50/60 Hz, TRLMTD	6115-01-346-0157		M510	52
Figure A-30	MEP-807A	100 kW TQG, 50/60 Hz, DED, Skid Mtd	6115-01-296-1463	Z47502	M54400	54
Figure A-31	PU-807A	100 kW TQ Power Unit, 50/60 Hz, TRLMTD	6115-01-471-7088	G17664	M54400	58
Figure A-32	MEP-809A	200 kW TQG, 50/60 Hz, DED, Skid Mtd	6115-01-296-1462	G1752B	M54400	59
Figure A-33	PU-809A	200 kW TQ Power Unit, 50/60 Hz, TRLMTD	6115-01-471-7085	G26345	M54400	62
Figure A-34	PU-810A	840 kW PU, 50/60 Hz, DED, WHLMTD (AF)	6115-01-486-4033	N/A	N/A	63
Figure A-35	PU-810B	840 kW PU, 50/60 Hz, DED, TRLRMTD	6115-01-486-4032			63
FIG	MODEL	ITEM DESCRIPTION	NSN	LIN	SSN	Page
Figure B- 1	MEP-952	5 kW, 28 VDC, DED/APU	6115-01-317-2139			68
Figure B- 2	MEP-903A	10 kW, 60 Hz, DED/APU	6115-01-431-3062			70
FIG	MODEL	ITEM DESCRIPTION	NSN	LIN	SSN	Page
Figure C- 1	MEP-362A	10 kW, 28VDC, GTED, Aircraft Support Unit, Integral wheel mount	6115-01-161-3992			74
Figure C- 2	MEP-356A	60 kW, 400 Hz; 2 kW, 28VDC; Pneumatic, Self Propelled, GTED, Aviation Ground Power Unit	6115-00-420-8486			76
Figure C- 3	MEP-357A	72 kW, 400 Hz; 21 kW, 28VDC; Self Propelled, DED, Aviation Support Unit	6115-00-110-1859			78



## MIL-HDBK-633A

Table II Cross Reference ordered by model number

FIG	MODEL	ITEM DESCRIPTION	NSN	LIN	SSN	Page
Figure C- 2	MEP-356A	60 kW, 400 Hz; 2 kW, 28VDC; Pneumatic, Self Propelled, GTED, Aviation Ground Power Unit	6115-00-420-8486			76
Figure C- 3	MEP-357A	72 kW, 400 Hz; 21 kW, 28VDC; Self Propelled, DED, Aviation Support Unit	6115-00-110-1859			78
Figure C- 1	MEP-362A	10 kW, 28VDC, GTED, Aircraft Support Unit, Integral wheel mount	6115-01-161-3992			74
Figure A-1	MEP-501A	2 kW MTG, 28 VDC, DED, Tubular Frame	6115-01-435-1567	G36169	M59400	16
Figure A-1	MEP-501A	2 kW MTG, 28 VDC, DED (First Buy)	6115-21-912-0392	G36169	M59400	16
Figure A-1	MEP-531A	2 kW MTG, 60 Hz, DED, Tubular Frame	6115-01-435-1565	G36237	M59400	16
Figure A-1	MEP-531A	2 kW MTG, 60 Hz, DED (First Buy)	6115-21-912-0393	G36237	M59400	16
Figure A-5	MEP-802A	5 kW TQG, 60 Hz, DED, Skid Mtd	6115-01-274-7387	G11966	M53500	22
Figure A-9	MEP-803A	10 kW TQG, 60 Hz, DED, Skid Mtd	6115-01-275-5061	G74711	M53500	27
Figure A-14	MEP-804B	15 kW TQG, 50/60 Hz, DED, Skid Mtd	6115-01-530-1458	G12170	M53500	34
Figure A-20	MEP-805B	30 kW TQG, 50/60 Hz, DED, Skid Mtd	6115-01-461-9335	G74575	M53500	41
Figure A-24	MEP-806B	60 kW TQG, 50/60 Hz, DED, Skid Mtd	6115-01-462-0291	G12034	M53500	47
Figure A-30	MEP-807A	100 kW TQG, 50/60 Hz, DED, Skid Mtd	6115-01-296-1463	Z47502	M54400	54
Figure A-32	MEP-809A	200 kW TQG, 50/60 Hz, DED, Skid Mtd	6115-01-296-1462	G1752B	M54400	59
Figure A-5	MEP-812A	5 kW TQG, 400 Hz, DED, Skid Mtd	6115-01-274-7391	G12102	M53500	22
Figure A-9	MEP-813A	10 kW TQG, 400 Hz, DED, Skid Mtd	6115-01-274-7392	G74779	M53500	27
Figure A-14	MEP-814B	15 kW TQG, 400 Hz, DED, Skid Mtd	6115-01-529-9494	G12238	M53500	34
Figure A-20	MEP-815B	30 kW TQG, 400 Hz, DED, Skid Mtd	6115-01-462-0290	G74643	M53500	41
Figure A-24	MEP-816B	60 kW TQG, 400 Hz, DED, Skid Mtd	6115-01-462-0292	G18052	M53500	47
Figure A-2	MEP-831A	3 kW TQG, 60 Hz, DED, Skid Mtd	6115-01-285-3012	G18358	M59400	18
Figure A-2	MEP-832A	3 kW TQG, 400 Hz, DED, Skid Mtd	6115-01-287-2431	G74847	M59400	18
Figure B- 2	MEP-903A	10 kW, 60 Hz, DED/APU	6115-01-431-3062			70
Figure B- 1	MEP-952	5 kW, 28 VDC, DED/APU	6115-01-317-2139			68
Figure A- 28	PP-AN.MJQ-1612	Power Plant, TQG, 60 kW, 400 Hz, TRLMTD	6115-01-349-1536		M510	52
Figure A- 29	PP-AN/MJQ-1632	Power Plant, TQG, 60 kW, 50/60 Hz, TRLMTD	6115-01-346-0157		M510	52
Figure A-7	PP-AN/MJQ-35A	5 kW TQ Power Plant, 60 Hz TRLMTD	6115-01-414-9697	P28083	R62700	25
Figure A-8	PP-AN/MJQ-36	5 kW TQ Power Plant, 60 Hz TRLMTD	6115-01-313-4215	P28151	R62700	26
Figure A-12	PP-AN/MJQ-37	10 kW TQ Power Plant, 60 Hz, TRLMTD	6115-01-299-6035	P42262	R62700	32
Figure A-13	PP-AN/MJQ-38	10 kW TQ Power Plant, 400 Hz, TRLMTD	6115-01-313-4214	P42330	R62700	33
Figure A-18	PP-AN/MJQ-39B	15 kW TQ Power Unit, 400 Hz, TRLMTD	6115-01-565-0701	P42614	R62700	39
Figure A-23	PP-AN/MJQ-40B	30 kW TQ Power Plant, 50/60 Hz TRLMTD	6115-01-474-3783	P42126	R62700	46
Figure A-27	PP-AN/MJQ-41B	60 kW TQ Power Plant, 50/60 Hz, TRLMTD	6115-01-474-3776	P42194	R62700	52
Figure A-3	PP-AN/MJQ-42	3 kW TQ Power Plant, 60 Hz, TRLMTD	6115-01-322-8583	Z13645	R62700	21
Figure A-4	PP-AN/MJQ-43/43A	3 kW TQ Power Plant, 60 Hz, TRLMTD	6115-01-322-8582	Z13713	R62700	21
Figure A-19	PP-AN/MJQ-48B	15 kW TQ Power Unit, 50/60 Hz, TRLMTD	6115-01-565-0691	Z01012	R62700	40
Figure A-6	PU-797A	5 kW TQ Power Unit, 60 Hz, TRLMTD	6115-01-413-3820	G42238	R62700	24
Figure A-10	PU-798A	10 kW TQ Power Unit, 60 Hz, TRLMTD	6115-01-413-3818	G42170	R62700	30
Figure A-11	PU-799A	10 kW TQ Power Unit, 400 Hz, TRLMTD	6115-01-413-3819	G53403	R62700	31
Figure A-15	PU-800A	15 kW TQ Power Unit, 400 Hz, TRLMTD	6115-01-565-0929	G78203	R62700	36
Figure A-16	PU-801B	15 kW TQ Power Unit, 50/60 Hz, TRLMTD	6115-01-565-0874	G78374	R62700	37
Figure A-17	PU-802A	15 kW TQ Power Unit, 50/60 Hz, TRLMTD	6115-01-565-1576	G53778	R62700	38
Figure A-21	PU-803B	30 kW TQ Power Unit, 50/60 Hz, TRLMTD	6115-01-470-6376	G35851	R62700	44
Figure A-22	PU-804B	30 kW TQ Power Unit, 400 Hz, TRLMTD	6115-01-471-1507	G35919	R62700	45
Figure A-25	PU-805B	60 kW TQ Power Unit, 50/60 Hz, TRLMTD	6115-01-471-1508	G78306	R62700	50
Figure A-26	PU-806B	60 kW TQ Power Unit, 400 Hz, TRLMTD	6115-01-471-1506	G17406	R62700	51
Figure A-31	PU-807A	100 kW TQ Power Unit, 50/60 Hz, TRLMTD	6115-01-471-7088	617664	M54400	58
Figure A-33	PU-809A	200 kW TQ Power Unit, 50/60 Hz, TRLMTD	6115-01-471-7085	G26345	M54400	62
Figure A-34	PU-810A	840 kW Power Unit, 50/60 Hz, DED, WHLMTD (AF)	6115-01-486-4033	N/A	N/A	63
Figure A-35	PU-810B	840 kW Power Unit, 50/60 Hz, DED, TRLRMTD	6115-01-486-4032			63

**MIL-HDBK-633A**

This Page Intentionally Left Blank

MIL-HDBK-633A  
APPENDIX A  
PRESENT STANDARD FAMILY OF MEPGS

## A.1 SCOPE

A.1.1 Scope. This Appendix identifies the current and soon to be fielded members of the DoD Standard Family of MEPGS to include trailer mounted configurations (Power Units and Power Plants). Data contained in this Appendix is provided to assist both field operation and materiel developer personnel to select the power generation source that will best meet their needs. DoD Directive 4120.11 requires DoD activities to use these power sources.

A.1.2 Appendix Organization. This Appendix is a compilation of characteristics data sheets arranged by power rating capacity (see [Table A-1](#)).

Table A-1 Guide to Characteristics Data Sheets of APPENDIX A

FIG	MODEL NO.	ITEM DESCRIPTION	NSN	LIN	SSN	Page
Figure A-1	MEP-501A	2 kW MTG, 28 VDC, DED, Tubular Frame	6115-01-435-1567	G36169	M59400	16
Figure A-1	MEP-501A	2 kW MTG, 28 VDC, DED (First Buy)	6115-21-912-0392	G36169	M59400	16
Figure A-1	MEP-531A	2 kW MTG, 60 Hz, DED, Tubular Frame	6115-01-435-1565	G36237	M59400	16
Figure A-1	MEP-531A	2 kW MTG, 60 Hz, DED (First Buy)	6115-21-912-0393	G36237	M59400	16
Figure A-2	MEP-831A	3 kW TQG, 60 Hz, DED, Skid Mtd	6115-01-285-3012	G18358	M59400	18
Figure A-2	MEP-832A	3 kW TQG, 400 Hz, DED, Skid Mtd	6115-01-287-2431	G74847	M59400	18
Figure A-3	PP-AN/MJQ-42	3 kW TQ Power Plant, 60 Hz, TRLMTD	6115-01-322-8583	Z13645	R62700	20
Figure A-4	PP-AN/MJQ-43/43A	3 kW TQ Power Plant, 60 Hz, TRLMTD	6115-01-322-8582	Z13713	R62700	21
Figure A-5	MEP-802A	5 kW TQG, 60 Hz, DED, Skid Mtd	6115-01-274-7387	G11966	M53500	22
Figure A-5	MEP-812A	5 kW TQG, 400 Hz, DED, Skid Mtd	6115-01-274-7391	G12102	M53500	22
Figure A-6	PU-797A	5 kW TQ Power Unit, 60 Hz, TRLMTD	6115-01-413-3820	G42238	R62700	24
Figure A-7	PP-AN/MJQ-35A	5 kW TQ Power Plant, 60 Hz TRLMTD	6115-01-414-9697	P28083	R62700	25
Figure A-8	PP-AN/MJQ-36	5 kW TQ Power Plant, 60 Hz TRLMTD	6115-01-313-4215	P28151	R62700	26
Figure A-9	MEP-803A	10 kW TQG, 60 Hz, DED, Skid Mtd	6115-01-275-5061	G74711	M53500	28
Figure A-9	MEP-813A	10 kW TQG, 400 Hz, DED, Skid Mtd	6115-01-274-7392	G74779	M53500	28
Figure A-10	PU-798A	10 kW TQ Power Unit, 60 Hz, TRLMTD	6115-01-413-3818	G42170	R62700	30
Figure A-11	PU-799A	10 kW TQ Power Unit, 400 Hz, TRLMTD	6115-01-413-3819	G53403	R62700	31
Figure A-12	PP-AN/MJQ-37	10 kW TQ Power Plant, 60 Hz, TRLMTD	6115-01-299-6035	P42262	R62700	32
Figure A-13	PP-AN/MJQ-38	10 kW TQ Power Plant, 400 Hz, TRLMTD	6115-01-313-4214	P42330	R62700	33
Figure A-14	MEP-804B	15 kW TQG, 50/60 Hz, DED, Skid Mtd	6115-01-530-1458	G12170	M53500	34
Figure A-14	MEP-814B	15 kW TQG, 400 Hz, DED, Skid Mtd	6115-01-529-9494	G12238	M53500	34
Figure A-15	PU-800A	15 kW TQ Power Unit, 400 Hz, TRLMTD	6115-01-565-0929	G78203	R62700	36
Figure A-16	PU-801B	15 kW TQ Power Unit, 50/60 Hz, TRLMTD	6115-01-565-0874	G78374	R62700	37
Figure A-17	PU-802A	15 kW TQ Power Unit, 50/60 Hz, TRLMTD	6115-01-565-1576	G53778	R62700	38
Figure A-18	PP-AN/MJQ-39B	15 kW TQ Power Unit, 400 Hz, TRLMTD	6115-01-565-0701	P42614	R62700	39
Figure A-19	PP-AN/MJQ-48B	15 kW TQ Power Unit, 50/60 Hz, TRLMTD	6115-01-565-0691	Z01012	R62700	40
Figure A-20	MEP-805B	30 kW TQG, 50/60 Hz, DED, Skid Mtd	6115-01-461-9335	G74575	M53500	42
Figure A-20	MEP-815B	30 kW TQG, 400 Hz, DED, Skid Mtd	6115-01-462-0290	G74643	M53500	42
Figure A-21	PU-803B	30 kW TQ Power Unit, 50/60 Hz, TRLMTD	6115-01-470-6376	G35851	R62700	44
Figure A-22	PU-804B	30 kW TQ Power Unit, 400 Hz, TRLMTD	6115-01-471-1507	G35919	R62700	45
Figure A-23	PP-AN/MJQ-40B	30 kW TQ Power Plant, 50/60 Hz TRLMTD	6115-01-474-3783	P42126	R62700	46
Figure A-24	MEP-806B	60 kW TQG, 50/60 Hz, DED, Skid Mtd	6115-01-462-0291	G12034	M53500	48
Figure A-24	MEP-816B	60 kW TQG, 400 Hz, DED, Skid Mtd	6115-01-462-0292	G18052	M53500	48
Figure A-25	PU-805B	60 kW TQ Power Unit, 50/60 Hz, TRLMTD	6115-01-471-1508	G78306	R62700	50
Figure A-26	PU-806B	60 kW TQ Power Unit, 400 Hz, TRLMTD	6115-01-471-1506	G17406	R62700	51
Figure A-27	PP-AN/MJQ-41B	60 kW TQ Power Plant, 50/60 Hz, TRLMTD	6115-01-474-3776	P42194	R62700	52
Figure A- 28	PP-AN.MJQ-1612	Power Plant, TQG, 60 kW, 400 Hz, TRLMTD	6115-01-349-1536		M510	54
Figure A- 29	PP-AN/MJQ-1632	Power Plant, TQG, 60 kW, 50/60 Hz, TRLMTD	6115-01-346-0157		M510	53
Figure A-30	MEP-807A	100 kW TQG, 50/60 Hz, DED, Skid Mtd	6115-01-296-1463	Z47502	M54400	56
Figure A-31	PU-807A	100 kW TQ Power Unit, 50/60 Hz, TRLMTD	6115-01-471-7088	617664	M54400	58
Figure A-32	MEP-809A	200 kW TQG, 50/60 Hz, DED, Skid Mtd	6115-01-296-1462	G1752B	M54400	60
Figure A-33	PU-809A	200 kW TQ Power Unit, 50/60 Hz, TRLMTD	6115-01-471-7085	G26345	M54400	62
Figure A-34	PU-810A	840 kW Power Unit, 50/60 Hz, DED, WHLMTD (AF)	6115-01-486-4033	N/A	N/A	64
Figure A-35	PU-810B	840 kW Power Unit, 50/60 Hz, DED, TRLMTD	6115-01-486-4032			64

MIL-HDBK-633A  
APPENDIX A

## A.2 APPLICABLE DOCUMENTS

A.2.1 This section is not applicable to this appendix.

## A.3 DEFINITIONS

A.3.1 Use definitions of basic document.

## A.4 GENERAL DESCRIPTIONS

A.4.1 Item Descriptions.

A.4.1.1 Military Tactical Generator (MTG). The MTG is a 2 kW diesel engine driven generator set used to meet user requirements of less than 3 kW power. The MTG was introduced into the US military system through the DoD Foreign Comparative Test (FTC) program. It is small, light weight, relatively quiet, and available in 60 Hz, 120V, single phase, and in 28 VDC versions.

A.4.1.2 Tactical Quiet Generator (TQG). The TQGs are reliable, quiet, and light weight diesel engine driven generator set in the 3 kW to 200 kW range. The TQGs incorporate commercial components engineered to meet military requirements and are procured in large quantities so they are relatively inexpensive.

A.4.1.3 Deployable Power Generation and Distribution System (DPGDS). A Quiet Prime Power Generator, a component of the Deployable Power Generation and Distribution System (DPGDS), replaces the 500 kW and 750 kW Military Standard generator sets. The DPGDS is diesel engine driven and generates 750 kW, 3 phase, 3800/4160 V, 50/60 Hz power.

A.4.1.4 Trailers. Several trailers are used in Power Unit and Power Plant MEPGS systems depending on size, weight and configuration.

a. Light Tactical Trailer (LTT)/ High Mobility Trailer (HMT). The LTT is a 1-1/4 ton trailer designed to match the cross country mobility of the High Mobility Multipurpose Wheeled Vehicle (HMMWV) while carrying a full payload. The HMT was the previous version of the LTT. Some PUPPs have been fielded with the HMT. Existing models of the PUPPs using the LTT or the HMT are designated as "A" Models.

b. M116A3. The M116A3 is a one ton trailer (3/4 ton modified to carry the extra weight of a generator set and its associated hardware). The mobility is sufficient to allow lower speed access to areas accessible to a HMMWV.

c. M103A3. The M103A3 is a 1-1/2 ton trailer modified to carry the extra weight of a generator set and its associated hardware.

d. M200A1. The M200A1 is a 2-1/2 ton trailer modified to carry the extra weight of a generator set and its associated hardware. The trailer is now configured with single radial tires in lieu of the dual bias tires although both configurations are presently in the field.

e. M106A1. The M106A1 is a 5 ton trailer.

A.4.2 Delivered condition.A.4.2.1 Skid sets.

a. Safety Items. Production generator sets may or may not be delivered with fire extinguishers, ground rods or ground rod slide hammer/puller. Units may obtain needed items. See [Table A- II](#) for details.

b. Batteries. Battery information is included in [Table A- II](#). The 2 kW Military Tactical Generator has no battery. It may be started manually or by external 24 VDC electrical power via the NATO slave connector.

c. Auxiliary Fuel Line. A 25 foot auxiliary fuel line is furnished with the 5 kW through 200 kW diesel engine driven generator sets. Fuel lines for the other sets may be ordered (see [Table A- II](#)) or fabricated on site in accordance with drawing 69-668 (see [Figure 1](#)).

d. Ether starting aid. Sets greater than 15 kW are equipped with an integral ether starting aid for temperatures below 40 °F. Ether bottles may be obtained as NSN 2910-00-209-4997.

e. Paralleling cables. Sets greater than 15 kW and above are designed for parallel operation as well as single set operation. Sets are supplied with a paralleling cable for interconnection of the voltage

## MIL-HDBK-633A

## APPENDIX A

regulators and governor systems of the sets to be paralleled. Additional details on parallel operation are contained in the generator set manuals and FM 5-424, Electrical Power Generation in the Field.

f. Power output terminals. Power output terminals consist of split-lug terminals with captive nuts. The Power Distribution and Illumination System, Electrical (PDISE) interfaces to the power output terminals via a pigtail connection. In addition, a series of standard power output receptacles (MIL-DTL-22992) are available through the supply system and the US Army Missile Command (MICOM) has a series of missile system receptacles for the 15 kW through 60 kW DoD generator sets.

g. NATO slave receptacle. A NATO slave receptacle is provided with all generator sets listed in this Appendix. The slave receptacle can be used to start the generator set from an external 24 VDC power source.

h. Convenience receptacle. A convenience receptacle is provided on all 60 Hz generator sets in this Appendix.

A.4.2.2 Trailer mounted sets. The trailer mounted sets (Power Units and Power Plants) are normally delivered with ground kit (ground rods, connectors, ground terminal), ground rod driver/puller, 8 pound hammer, and a fire extinguisher per trailer. See [Table A- II](#) for details.

A.4.3 Winterization Kit. A fuel burning winterization kit can be installed inside the TQG sets to extend the starting and operation temperature down to -50 °F. The kit NSNs and application can be found in [Table A- II](#) that follows and in the Characteristics Data Sheets.

Table A- II Batteries and Auxiliary Equipment

<b>Batteries</b>			
<b>Model</b>	<b>Description</b>	<b>Nsn</b>	<b>Application</b>
Concord	Starved-Electrolyte – 24 Volt	6140-01-374-8502	3 kW TQG
2HN	Lead-Acid – 12 Volt	6140-00-057-2553	5 kW TQG
6TL	Lead-Acid – 12 Volt	6140-01-210-1964	15 kw - 60 kW TQG
Optima d51r	Starved Electrolyte – 12 Volt	6140-01-529-7226	5 kW TQG
Optima 800s	Starved-Electrolyte – 12 Volt	6140-01-374-2243	10 kW TQG
Optima 800s	Starved-Electrolyte – 12 Volt	6140-01-378-8232	15, 30,60 kW TQG
Optima 8050-160	Starved-Electrolyte – 12 Volt		100 and 200 kW TQG
	Adapter For Optima	6160-01-453-0858	
<b>Grounding items</b>			
<b>Model</b>	<b>Description</b>	<b>Nsn</b>	<b>Application</b>
	Ground Rod Kit (Includes Rod, Connectors, Terminal)	5975-00-828-3791	TQG, PU, PP
	Ground Rod (3 Ft Sec)	5975-00-249-6798	TQG, PU, PP
	Driver/Puller (Slide Hammer)	5120-01-013-1676	PU, PP
	Hammer, 8 Pound	5120-00-251-4489	PU, PP
<b>Fuel handling items</b>			
<b>Model</b>	<b>Description</b>	<b>Nsn</b>	<b>Application</b>
	Auxiliary Fuel Line	4720-00-021-3320	TQG, PU, PP
	Fuel Container/Drum Adapter	2910-00-066-1235	PU, PP
	5 Gal Fuel Can	7240-00-222-3088	PU, PP
	Spout	7240-00-177-6154	PU, PP
<b>Fire extinguisher</b>			
<b>Model</b>	<b>Description</b>	<b>Nsn</b>	<b>Application</b>
A-A-1106	5 lb CO <sub>2</sub> Fire Extinguisher	4210-00-270-4512	All
<b>Optional equipment</b>			
<b>Model</b>	<b>Description</b>	<b>Nsn</b>	<b>Application</b>
	Winterization Kit	6115-01-476-8973	5kW TQGs
	Winterization Kit	6115-01-477-0564	10kW TQGs
	Winterization Kit	6115-01-477-0566	15kW TQGs
	Winterization Kit	6115-01-474-8354	30kW TQGs
	Winterization Kit	6115-01-474-8244	60kW TQGs

MIL-HDBK-633A  
APPENDIX A

A.5 DETAILED DESCRIPTIONS

A.5.1 Detailed Descriptions. Details of skid and trailer-mounted sets are contained in [Figure A-1](#) through [Figure A-35](#) CHARACTERISTICS DATA SHEETS. See [Table A-1](#) Guide to Characteristics Data Sheets of APPENDIX A

MIL-HDBK-633A  
APPENDIX A

This Page Intentionally Left Blank

## MIL-HDBK-633A

## APPENDIX A

## 2 kW Military Tactical Generator Set

Identification Data			
Description	2 kW MTG Set, 60 Hz, DED, Tubular Frame	2 kW MTG Set, 28 VDC, DED, Tubular Frame	
Model	MEP-531A	MEP-501A	
NSN (first buy)	6115-21-912-0393	6115-21-912-0392	
NSN	6115-01-435-1565	6115-01-435-1567	
LIN	G36237	G36169	
SSN	M59400	M59400	
Physical Characteristics			
Dimensions LWH (in)	30 x16 x 22 (Cube: 6 ft <sup>3</sup> )		
Wet Weight (lbs)	MEP-531A: 158	MEP-501A: 138	
Engine	Yanmar L48AE-DEG Diesel, 1 cylinder/4 stroke, 4.2 horsepower @ 3600 RPM, air cooled, 24 VDC start from NATO slave receptacle, recoil pull starter.		
Instrumentation	Voltmeter, ammeter, hour meter, frequency meter (AC only).		
Fuels	Diesel DL-1, DL-2 and JP-8		
Fuel Capacity	Fuel tank: 1.6 gal.		
Performance Characteristics			
Power Rating	2kW, 1.0 pf @4000 ft/95°F. 110% Max power; derate: 1.3%/328 ft from 4000 to 8000ft		
Environmental Capability	-40°F to 120°F, rain, humidity, altitude, sand/ dust, rail transport, -65°F cold storage, salt spray, fungus, 15° incline		
Protective Devices	Trip circuit breaker for overload/short circuit. Automatic shutdown for low oil pressure.		
Fuel consumption	0.33 gph @ rated load.	0.33 gph @ rated load.	
Human Factors	MIL-STD-1474: 4 soldier portable: operable in chemical/arctic clothing.		
Noise	79 dBA @ 7 meters (23 ft).		
Reliability (MTBF)	818 hr	490 hr	
Maintenance Ratio	0.033 – organization;	0.008 – direct support.	
Electrical Characteristics			
Voltage Connection	120 V, 1 phase, 2 wire	28 VDC, 2 wire	
Voltage adj. Range	114 to 126 V	26.6 – 32.0 V	
Freq. adj. Range	±5.5%	N/A	
Electrical	Drip proof generator enclosure, fungus & moisture treated, solid state voltage regulator, brush type 2 pole alternator, solderless connectors, AC alternator: Mechron Power, DC Alternator: Balmar.		
Electrical Performance			
Electric Power Quality	AC Voltage	Frequency	DC Voltage
Regulation	4%	5.6%	4%
Voltage modulation	2%		
Short term steady state stability (30 sec)	2% bandwidth	3% bandwidth	2% bandwidth
Long term steady state stability (4 hr)	4% bandwidth	3% bandwidth	2% bandwidth
Application of rated load (transient), recovery time	30% dip, 3 sec,	8% undershoot, 4 sec	30% dip, 1 sec
Rejection of rated load (transient), recovery time	30% rise, 3 sec	10% overshoot, 5 sec	40% rise, 0.5 sec
Motor load	not rated		
Max waveform deviation factor	16%		
Individual waveform harmonic	15%		
DC ripple			7%
EMI	Meets MIL-STD-461C Not Protected		
EMP	Not protected.		
Optional Equipment			
Description	NSN	Weight (lbs)	Effect on Dimensions (in)
Auxiliary Fuel System	See TM 9-6115-673-13&P		
Technical Manuals			
Description	Army	Air Force	Marine Corps
Operator, Unit, DS/GS, Parts	TM 9-6115-673-13&P	TO 35C2-3-512-1	None



MIL-HDBK-633A  
APPENDIX A



MEP-501A, 28 VDC



MEP-531A, 120 V, 60 Hz  
has an additional meter (frequency) and a  
convenience receptacle

**TOP VIEW**

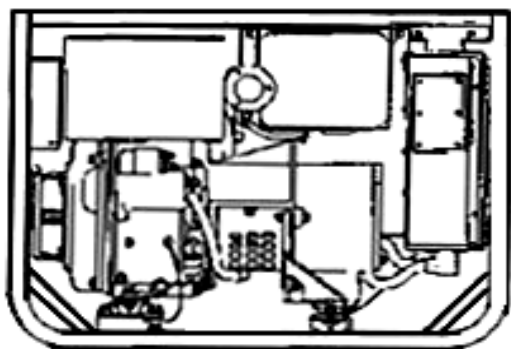
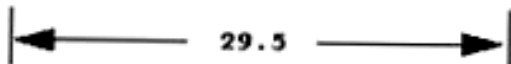
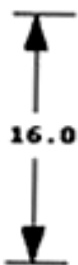
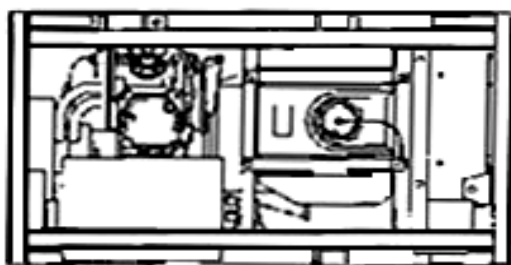

**RIGHT SIDE**

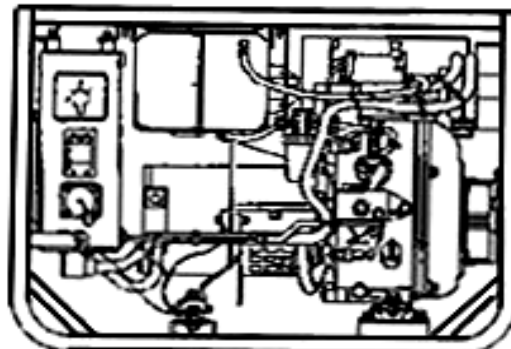
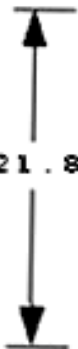

**LEFT SIDE**

Figure A-1 2 kW Military Tactical Generator Set

## MIL-HDBK-633A

## APPENDIX A

## 3 kW Tactical Quiet Generator Set (TQG)

Identification Data			
Description	3 kW TQG Set, 60 Hz, DED, Skid Mtd		3 kW TQG, 400 Hz, DED, Skid Mtd
Model	MEP-831A		MEP-832A
NSN	6115-01-285-3012		6115-01-287-2431
LIN	G18358		G74847
SSN	M59400		M59400
Trailer mounted configurations	PP-AN/MJQ-42: <a href="#">Figure A-3</a> PP-AN/MJQ-43, PP-AN/MJQ-43A: <a href="#">Figure A-4</a>		None
Physical Characteristics			
Dimensions LWH (in)	35 x 28 x 27 (Cube:15 ft <sup>3</sup> )		
Weight (lbs)	326 (full tank + battery), 272 (1 hr fuel, no battery)		
Engine	Yanmar L70AE-D/DE Diesel, 1 cylinder/4 stroke, 6.7 hp @ 3600 RPM (variable speed), rope and 24 VDC start, air-cooled.		
Instrumentation	Emergency stop, Fuel level, Hour meter, Voltmeter, Load meter, Battle short, AC interrupt, Fault indicators		
Fuels	Diesel DL-1, DL-2; Jet Fuel JP-8		
Fuel Capacity	Fuel tank: 4.0 gal		
Performance Characteristics			
Power Rating	3 kW, 0.8 pf @ 1000 ft/107°F. 110% max power.		
Environmental Capability	-25°F to 120°F, rain, humidity, altitude, sand/dust, transportation, 9 inch drop, vibration, cold storage, salt spray, fungus, 15° incline.		
Protective Devices	Engine High Temp, Low Oil Pressure, No Fuel, Overvoltage, Overload, Short Circuit		
Fuel consumption	0.33 gph @ rated load		
Human Factors	MIL-STD-1474. Man portable.		
Noise	72 dBA @ 7 m (23 ft.)		
Reliability (MTBF)	500 hr @ 80% Lower Confidence Level (LCL)		
Maintenance ratio	less than 0.05		
Electrical Characteristics			
Connection	120/240V, 1ph, 3 wire		120V, 1ph, 2 wire
Voltage Adj Range	228 – 252 V		114 – 126 V
Frequency Adj Range	3%		
Electrical	Fermont Permanent Magnet Variable Speed Generator, TRC Corp Solid State Inverter (60Hz and 400Hz).		
Electrical Performance			
Electric Power Quality	AC Voltage		Frequency
Regulation	4%		3%
Modulation	2.5%		
Short term steady state stability (30 sec)	2% bandwidth		4% bandwidth
Long term steady state stability (4 hr)	4% bandwidth		4% bandwidth
Application/rejection of rated load, recovery time	30% dip/rise, 3 sec		4% under/5% over, 4 sec/6 sec
Motor load	Not rated		
Max waveform deviation factor	7%		
Individual waveform harmonic	4%		
EMI	Meets MIL-STD-461C		
EMP	HAEMP IAW MIL-STD-2169		
Optional Equipment			
Description	NSN	Weight (lbs)	Effect on Dimensions (in)
None			
Technical Manuals			
Description	Army	Air Force	Marine Corps
Operator, Unit, DS	TM 9-6115-639-13&P	TO 35C2-3-386-51W/IPB	TM 10155A-OI/1
RPSTL	TM 9-6115-639-13&P	TO 35C2-3-386-51W/IPB	TM 10155A-OI/1
Engine Maint Manual	TM9-2815-257-24	TO 38G1-128-2	TM 10155A/2815-24/3
Engine RPSTL	TM9-2815-257-24P	TO 38G1-128-4	TM 10155A/2815-24P/4

MIL-HDBK-633A  
APPENDIX A



MEP-831A (60 Hz) has convenience outlet and fault protection  
Radii: Access door = 25.4", Output Terminal door = 10.0", Control Panel door = 8.5".

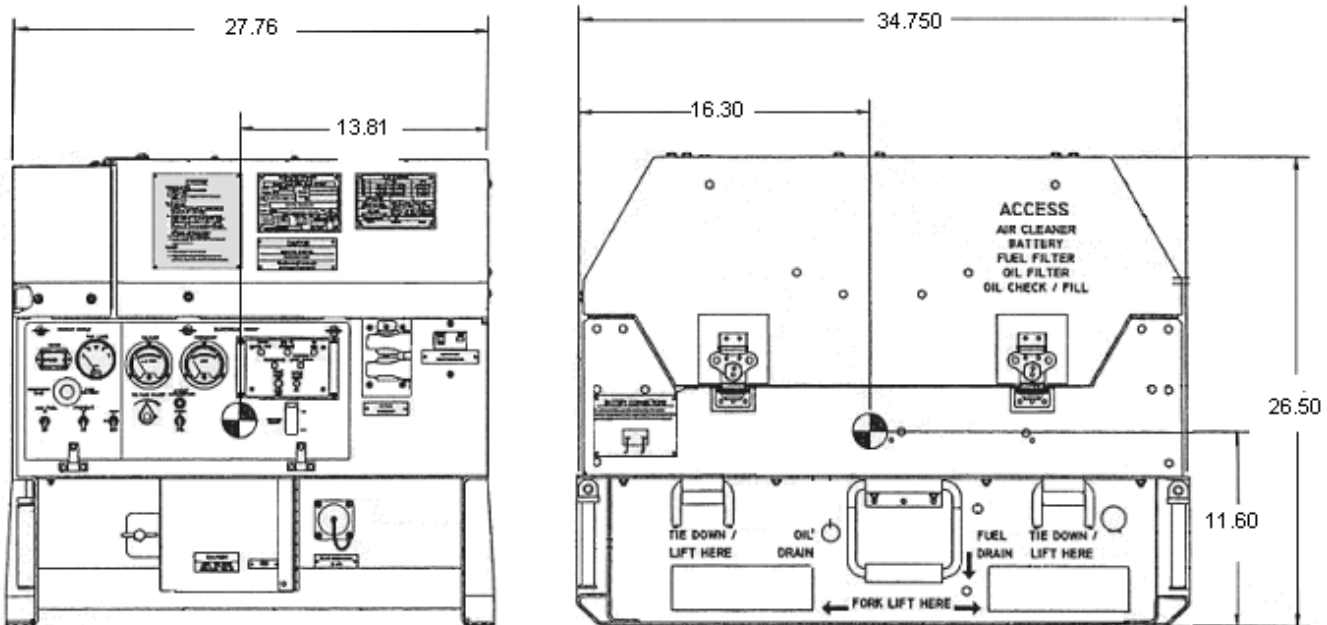

Figure A-2 3 kW Tactical Quiet Generator Set

MIL-HDBK-633A

APPENDIX A

3 kW Tactical Quiet Power Plant, 60 Hz, TRLMTD

Identification Data					
Description	3 kW TQ Power Plant, 60 Hz, TRLMTD			Camouflage: 97403-13226E7477	
<b>Model</b>	<b>NSN</b>	<b>LIN</b>	<b>SSN</b>	<b>ASSEMBLY</b>	<b>SPEC</b>
PP-AN/MJQ-42	6115-01-322-8583	P42466	R62700	TA-13229E5720	MIL-P-53132/2
Tech. Manual	Operator, Unit and Direct Support			TM 9-6115-658-13&P	
Physical Characteristics					
<b>Model</b>	<b>Dimensions:LWH (in) &amp; Cube(ft<sup>3</sup>)</b>	<b>Ship Cube (ft<sup>3</sup>)</b>	<b>Wet weight (lbs)</b>	<b>Ship Weight (lbs)</b>	
PP-AN/MJQ-42	145 x 84 x 76 & (533)	533	2900	2412	

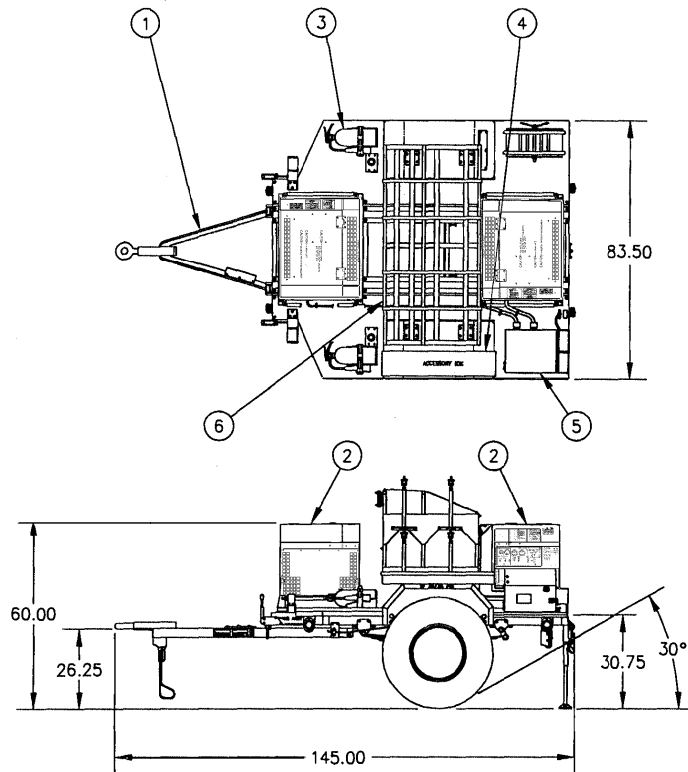

N/MJQ-42

FIND	COMPONENT	QTY	IDENTIFIER
1	Modified 1 ton trailer, M116A3	1	97403-13230E6832
2	TQ Generator set, DED, 3 kW, 60. Hz, MEP-831A	2	6115-01-285-3012
3	Fire extinguisher, 5 lb., A-A-1106	2	4210-00-270-4512
4	Accessory box	1	97403-13229E7946
5	Switch box	1	97403-13230E6950
6	Rack Assembly (includes cable reel)	1	TBD

Figure A-3 PP-AN/MJQ-42

## MIL-HDBK-633A

## APPENDIX A

## 3 kW Tactical Quiet Power Plant, 60 Hz, TRLMTD

Identification Data					
Description	3 kW TQ Power Plant, 60 Hz, TRLMTD			Camouflage: 97403-13226E7477	
<b>Model</b>	<b>NSN</b>	<b>LIN</b>	<b>SSN</b>	<b>ASSEMBLY</b>	<b>SPEC</b>
PP-AN/MJQ-43	6115-01-322-8582	P42534	R62700	TA-13229E5730	MIL-P-53132/1
PP-AN/MJQ-43A*	6115-01-322-8582	P42534	R62700	TA-13229E5730	MIL-P-53132/1
Technical Manual	Operator, Unit and Direct Support			TM 9-6115-658-13&P	
*An "A" Model will use the Light Tactical Trailer (LTT)					
Physical Characteristics					
<b>Model</b>	<b>Dimensions: LWH (in) &amp; (Cube) (ft<sup>3</sup>)</b>	<b>Ship Cube (ft<sup>3</sup>)</b>	<b>Wet weight (lbs)</b>	<b>Ship Weight (lbs)</b>	
PP-AN/MJQ-43	135 x 86 x 60 & (421)	421	2212	2187	
PP-AN/MJQ-43A	135 x 86 x 60 & (421)	421	2212	2187	

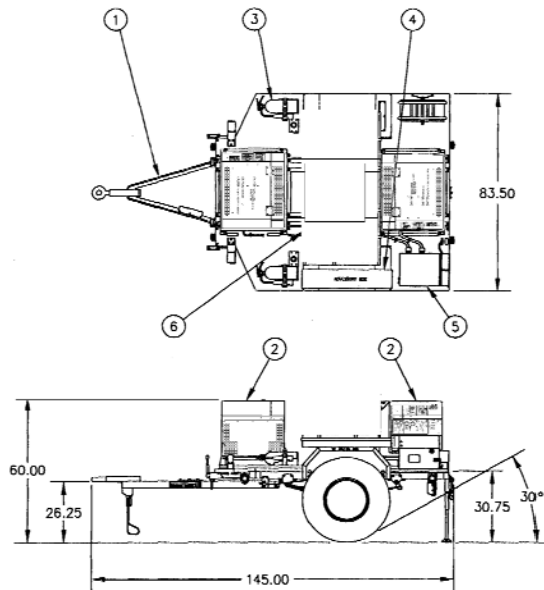

FIND	COMPONENT	QTY	IDENTIFIER
1	Light Tactical Trailer (LTT) (A Model)	1	97403-13230E6565
1	Modified 1 ton trailer, M116A3 (shown)	1	97403-13230E6832
2	TQ Generator set, DED, 3 kW, 60. Hz, MEP-831A	2	6115-01-285-3012
3	Fire extinguisher, 5 lb., A-A-1106	2	4210-00-270-4512
4	Accessory box	1	97403-13229E7946
5	Switch box	1	97403-13230E6950

Figure A-4 PP-AN/MJQ-43 and PP-AN/MJQ-43A

## MIL-HDBK-633A

## APPENDIX A

**5 kW Tactical Quiet Generator Set (TQG)**

<b>Identification Data</b>			
Description	5 kW TQG, 60 Hz, DED, Skid Mtd		5 kW TQG, DED, 400Hz, Skid Mtd
Model	MEP-802A		MEP-812A
NSN	6115-01-274-7387		6115-01-274-7391
LIN	G11966		G12102
Specification	MIL-DTL-53133/1		MIL-DTL-53133/2
SSN	M53500		M53500
Trailer mounted configurations	PU- 797A: <a href="#">Figure A-6</a> ; AN/MJQ- 35A: <a href="#">Figure A-7</a> and; AN/MJQ-36: <a href="#">Figure A-8</a>		None
<b>Physical Characteristics</b>			
Dimensions LWH (in)	51 x 32 x 37 (Cube:34 ft <sup>3</sup> )		
Wet Weight (lbs)	888	911	
Engine	Onan DN2M Diesel, 2 cylinder/4 stroke, 11.0hp @1800 RPM, 24VDC start, liquid-cooled.		
Instrumentation	Hour meter, voltmeter, frequency, amps (% RL), oil pressure, fuel, coolant temp, battery amps, emergency stop, battle short		
Fuels	Diesel DL-1, DL-2; Jet Fuel JP-8		
Fuel Capacity	Fuel tank: 5 gallons		
<b>Performance Characteristics</b>			
Power Rating	5kW, 0.8 pf @ 4000ft/120°F; 110% Max Power; De-rate: 3.5%/1000 ft from 4000 to 8000 ft		
Environmental Capability	-25°F (-50°F with Winterization Kit) to 125°F, rain, humidity, altitude, sand/dust, transportation, cold storage: -60°F, salt spray, fungus, 15° incline.		
Protective Devices	Automatic shut down with emergency bypass for low oil pressure, coolant high-temp, no fuel, and over-voltage.		
Fuel Consumption	0.57 gph @ rated load.	0.56 gph @ rated load.	
Human Factors	MIL-STD-1474.		
Noise	70 dBA @ 7 meters (23 ft).		
Reliability (MTBF)	486 hr @ 80% LCL	479 hr @ 80% LCL	
Maintenance Ratio	less than 0.05		
<b>Electrical Characteristics</b>			
<b>Connection</b>	<b>120/240V, 1ph, 3 wire</b>	<b>120V, 1ph, 2 wire</b>	<b>120/208V, 3ph, 4 wire</b>
Voltage Adj Range	228 –252 V	114 – 126 V	205 –220 V
Frequency Adj Range	±3%		
Electrical	Drip-proof generator enclosure, fungus & moisture treated, solid state voltage regulator, brushless rotary exciter, solderless connectors, 60Hz: Onan alternator, 4 pole; 400Hz: Onan alternator, 24 pole. Convenience receptacle on 60Hz set.		
<b>Electrical Performance</b>			
<b>Electric Power Quality</b>	<b>AC Voltage</b>		<b>Frequency</b>
Regulation	3%		3%
Modulation	2.5%		
Short term steady state stability (30 sec)	2% bandwidth		2% bandwidth
Long term steady state stability (4 hr)	4% bandwidth		3% bandwidth
Appl./rejection of rated load, recovery time	20% dip/rise, 3 sec		3% under/4% over, 3 sec
Motor load	35% dip, 5 sec to 95% init volt		
Max waveform deviation factor	6% (1 phase); 5% (3 phase)		
Individual waveform harmonic	3% (1 phase); 2% (3 phase)		
EMI	Meets MIL-STD-461C, Part 9		
EMP	HAEMP IAW MIL-STD-2169		
<b>Optional Equipment</b>			
<b>Description</b>	<b>NSN</b>	<b>Tech Bulletin</b>	<b>Effect on Dimensions (in)</b>
Winterization kit	6115-01-476-8973	TB 9-6115-641-13	None (internal)
<b>Technical Manuals</b>			
	<b>Army</b>	<b>Air Force</b>	<b>Marine Corps</b>
Operator	TM 9-6115-641-10	TO 35C2-3-456-11	None
Unit, DS, GS	TM 9-6115-641-24	TO 35C2-3-456-12	
RPSTL	TM 9-6115-641-24P	TO 35C2-3-456-14	
Engine Maintenance	TM 9-2815-252-24	TO 38G1-92-2	
Engine Parts	TM 9-2815-252-24P	TO 38G1-92-4	
Lube Order	LO 9-6115-641-12		
Warranty	TB 9-6115-641-24		

MIL-HDBK-633A  
APPENDIX A



MEP-802A or MEP-812A

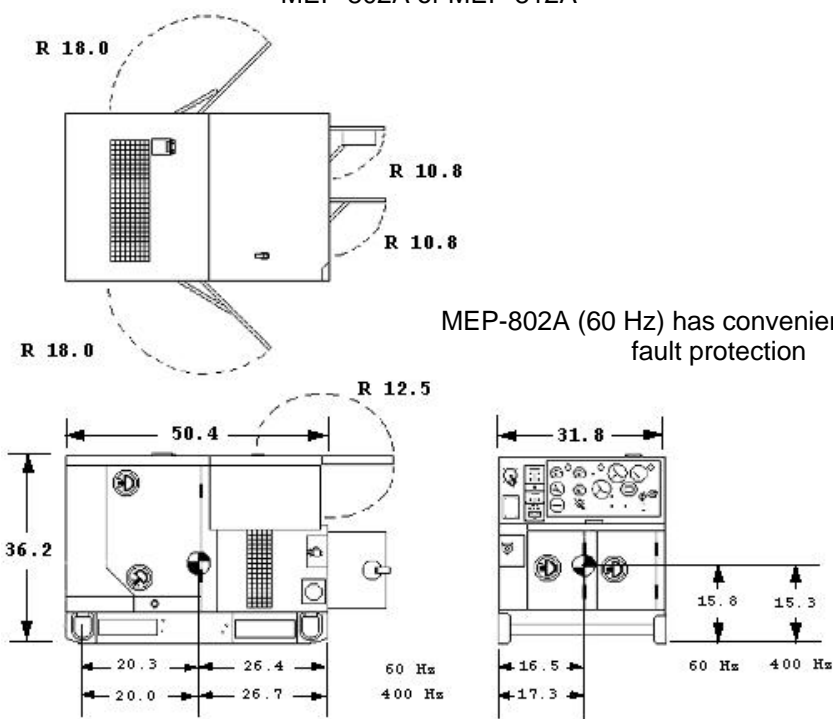

Figure A-5 5 kW Tactical Quiet Generator Set

MIL-HDBK-633A

APPENDIX A

## 5 kW TQ Power Unit, 60 Hz, TRLMTD

Identification Data					
Description	TQ POWER UNIT, 5 kW, 60 Hz, TRLMTD			Camouflage: 97403-13228E1608	
<b>Model</b>	<b>NSN</b>	<b>LIN</b>	<b>SSN</b>	<b>ASSEMBLY</b>	<b>SPEC</b>
PU-797A	6115-01-413-3820	G42238	R62700	TA-13230E6520	
Technical Manual	Operator, Unit and Direct Support			TM 9-6115-659-13&P	
Physical Characteristics					
<b>Dimensions LWH (in) &amp; (Cube) (ft<sup>3</sup>)</b>		<b>Ship Cube (ft<sup>3</sup>)</b>		<b>Wet Weight (lbs)</b>	<b>Ship Weight (lbs)</b>
135 x 86 x 72 & (483)		483		2320	2360

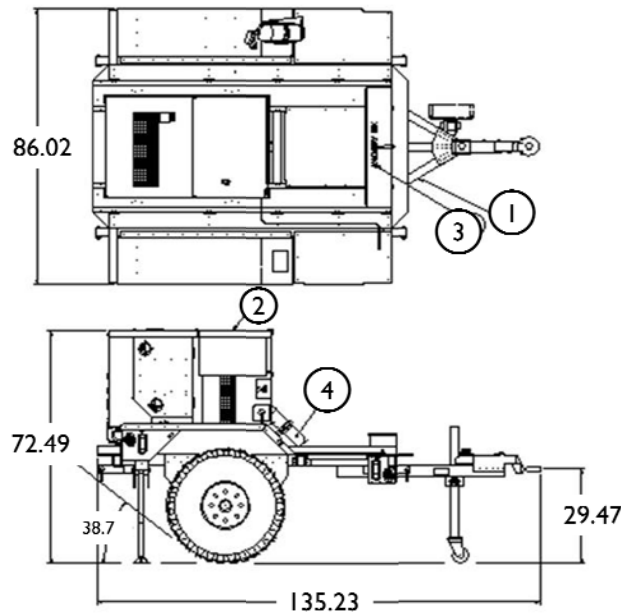

FIND	COMPONENT	QTY	IDENTIFIER
1	Light Tactical Trailer (PU-797A)	1	97403-13230E6565
2	TQ Generator set, DED, 5 kW, 60 Hz, MEP-802A	1	6115-01-274-7387
3	Accessory box	1	97403-13229E7946
4	Fire extinguisher, 5 lb., A-A-1106	1	4210-00-270-4512

Figure A-6 PU-797A



MIL-HDBK-633A

APPENDIX A

5 kW TQ Power Plant, 60 Hz, TRLMTD

Identification Data					
Description	TQ POWER PLANT, 5 kW, 60 Hz, TRLMTD			Camouflage: 97403-13228E1609	
<b>Model</b>	<b>NSN</b>	<b>LIN</b>	<b>SSN</b>	<b>ASSEMBLY</b>	<b>SPEC</b>
PP-AN/MJQ-35A	6115-01-414-9697	P28083	R62700	TA-13230E6560	
Technical Manual	Operator, Unit and Direct Support			TM 9-6115-659-13&P	
Physical Characteristics					
<b>Dimensions (LWH (in)) &amp; (Cube) (ft<sup>3</sup>)</b>		<b>Ship Cube (ft<sup>3</sup>)</b>		<b>Wet Weight (lbs)</b>	<b>Ship Weight (lbs)</b>
135 x 86 x 72 & ( 483)		483		3223	3140

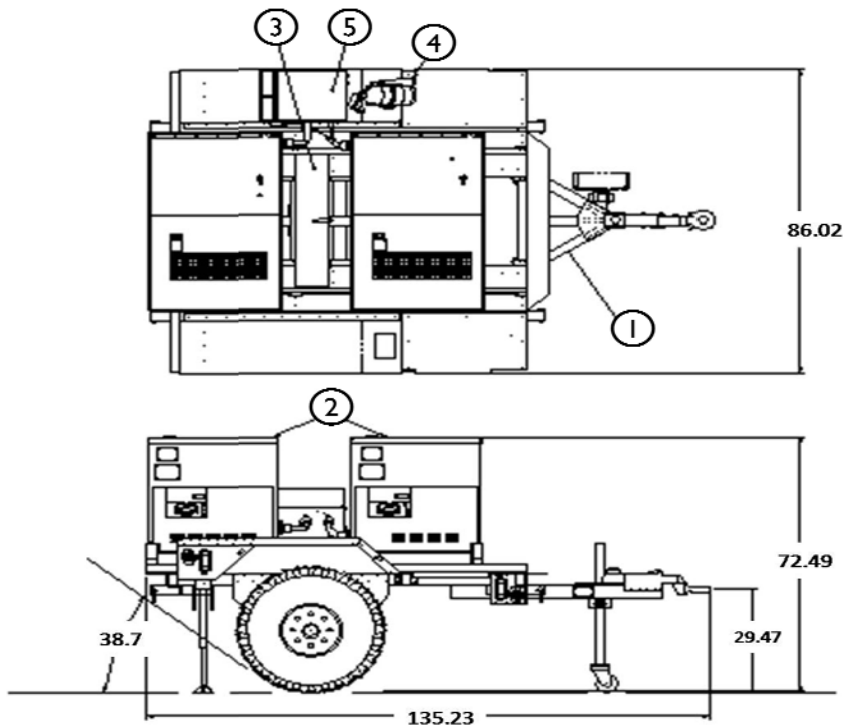

FIND	COMPONENT	QTY	IDENTIFIER
1	Light Tactical Trailer (LTT) (PP-AN/MJQ-35A)	1	97403-13230E6565
2	TQ Generator set, DED, 5 kW, 60 Hz, MEP-802A	2	6115-01-274-7387
3	Accessory box	1	97403-13229E7946
4	Fire extinguisher, 5 lb., A-A-1106	1	4210-00-270-4512
5	Switch box	1	97403-13230E6535

Figure A-7 PP-AN/MJQ-35A

MIL-HDBK-633A  
 APPENDIX A  
 5 kW TQ Power Plant, 60 Hz, TRLMTD

Identification Data					
Description	TQ POWER PLANT, 5 kW, 60 Hz, TRLMTD			Camouflage: 97403-13228E1610	
<b>Model</b>	<b>NSN</b>	<b>LIN</b>	<b>SSN</b>	<b>ASSEMBLY</b>	<b>SPEC</b>
PP-AN/MJQ-36	6115-01-313-4215	P28151	R62700	TA-13229E5660	MIL-P-53132/4
Technical Manual	Operator, Unit and Direct Support			TM 9-6115-659-13&P	
Physical Characteristics					
<b>Dimensions LWH (in) &amp; (Cube) (ft<sup>3</sup>)</b>		<b>Ship Cube (ft<sup>3</sup>)</b>		<b>Wet Weight (lbs)</b>	<b>Ship Weight (lbs)</b>
165 x 83 x 71 & (562)		562		3785	3985

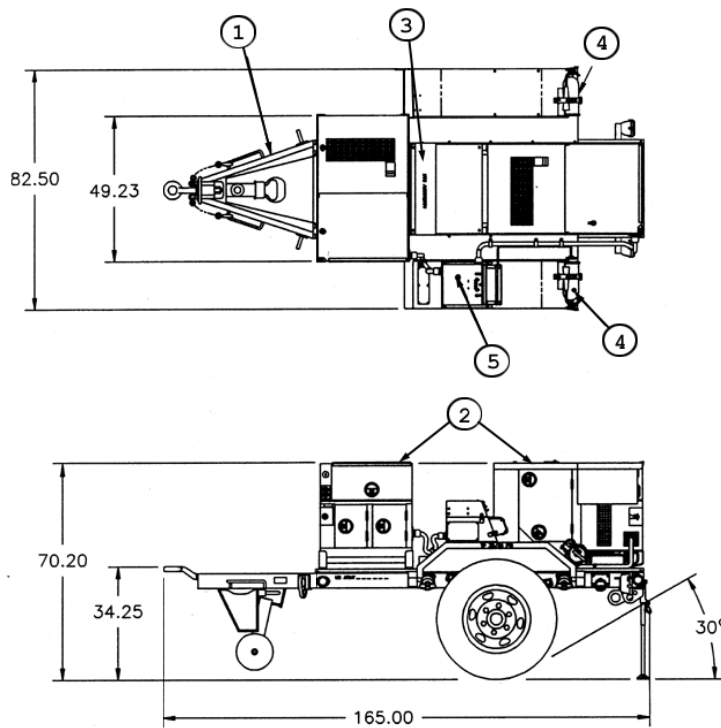

FIND	COMPONENT	QTY	IDENTIFIER
1	1-1/2 Ton modified trailer, M103A3	1	97403-13229E5825
2	Generator set, TQ DED, 5 kW, 60 Hz, MEP-802A	2	6115-01-274-7387
3	Accessory box	1	97403-13229E7946
4	Fire extinguisher, 5 lb., A-A-1106	2	4210-00-270-4512
5	Switch box	1	97403-13230E6535

Figure A-8 PP-AN/MJQ-36

MIL-HDBK-633A  
APPENDIX A

This Page Intentionally Left Blank

## MIL-HDBK-633A

## APPENDIX A

## 10 kW Tactical Quiet Generator Set (TQG)

Identification Data			
Description	10 kW TQG, 60 Hz, DED, Skid Mtd		10 kW TQG, 400 Hz, DED, Skid Mtd
Model	MEP-803A		MEP-813A
NSN	6115-01-275-5061		6115-01-274-7392
LIN	G74711		G74779
Specification	MIL-DTL-53133/3		MIL-DTL-53133/4
SSN	M53500		M53500
Trailer mounted configurations	PU-798A: <a href="#">Figure A-10</a> PP-AN/MJQ-37: <a href="#">Figure A-12</a>		PU-799A: <a href="#">Figure A-11</a> PP-AN/MJQ-38: <a href="#">Figure A-13</a>
Physical Characteristics			
Dimensions LWH (in)	62 x 32 x 37 (Cube:41 ft <sup>3</sup> )		
Wet Weight (lbs)	1182	1220	
Engine	Diesel, Onan model: DN4M-1, 4 cycle, 22 horsepower @ 1800 RPM, 24 VDC start, Liquid cooled.		
Instrumentation	Hour meter, voltmeter, frequency, amps (% RL), oil pressure, fuel, coolant temp, battery amps, emergency stop, battle short.		
Fuels	Diesel DL-1, DL-2; Jet Fuel JP-8		
Fuel Capacity	Fuel tank: 9 gallons		
Performance Characteristics			
Power Rating	10kW, 0.8 pf @ 4000 ft/120°F; 110% Max Power; De-rate: 3.5%/1000 ft from 4000 to 8000 ft		
Environmental Capability	-25°F (-50°F with Winterization Kit) to 125°F, rain, humidity, altitude, sand/dust, transportation, cold storage: -60°F, salt spray, fungus, 15° incline.		
Protective Devices	Automatic shut down with emergency bypass for low oil pressure, coolant high-temp, no fuel, and over-voltage.		
Fuel Consumption	0.97 gph @ rated load.	1.00 gph @ rated load.	
Human Factors	MIL-STD-1474.		
Noise	70 dBA @ 7 meters (23 ft).		
Reliability (MTBF)	771 hr @ 80% LCL	527 hr @ 80% LCL	
Maintenance Ratio:	less than 0.05		
Electrical Characteristics			
<b>Connection</b>	<b>120/240V, 1ph, 3 wire</b>	<b>120V, 1ph, 2 wire</b>	<b>120/208V, 3ph, 4 wire</b>
Voltage Adj Range	228 – 252 V	114 – 126 V	205 – 220 V
Frequency Adj Range	±3%		
Electrical	Drip proof generator enclosure, fungus & moisture treated, solid state voltage regulator, solderless connectors, Onan synchronous rotating field generator: 60 Hz: 4 pole alternator, 400 Hz: 24 pole.		
Electrical Performance			
<b>Electric Power Quality</b>	<b>AC Voltage</b>		<b>Frequency</b>
Regulation	3%		3%
Modulation	1%		
Short term steady state stability (30 sec)	2% bandwidth		2% bandwidth
Long term steady state stability (4 hr)	4% bandwidth		3% bandwidth
Appl./rejection of rated load, recovery time	20% dip/rise, 3 sec		3% under/4% over, 3 sec
Motor load	35% dip, 5 sec to 95% init volt		
Max waveform deviation factor	6% (1 phase); 5% (3 phase)		
Individual waveform harmonic	3% (1 phase); 2% (3 phase)		
EMI	Meets MIL-STD-461C Part 9		
EMP	HAEMP IAW MIL-STD-2169		
Optional Equipment			
<b>Description</b>	<b>NSN</b>	<b>Tech Bulletin</b>	<b>Effect on Dimensions (in)</b>
Winterization kit	6115-01-477-0564	TB9-6115-642-13	None (internal)
Technical Manuals			
	<b>Army</b>	<b>Air Force</b>	<b>Marine Corps</b>
Operators	TM 9-6115-642-10	TO 35C2-3-455-11	TM 09247A/09248A-10/1
Unit, DS, GS	TM 9-6115-642-24	TO 35C2-3-455-12	TM 09247A/09248A-24/2
RPSTL	TM 9-6115-642-24P	TO 35C2-3-455-14	TM 09247A/09248A-24P/3
Lube Order	LO 9-6115-642-12		LI 09247A/09248A-12
Warranty TO	TB 9-6115-642-24		SI 09247A/09248A-24
Engine Maintenance	TM 9-2815-253-24	TO 38G1-93-2	TM 2815-24/3
Engine Parts	TM 9-2815-253-24P	TO 38G1-93-4	TM 2815-24P/1

MIL-HDBK-633A  
APPENDIX A



MEP-803A or MEP-813A

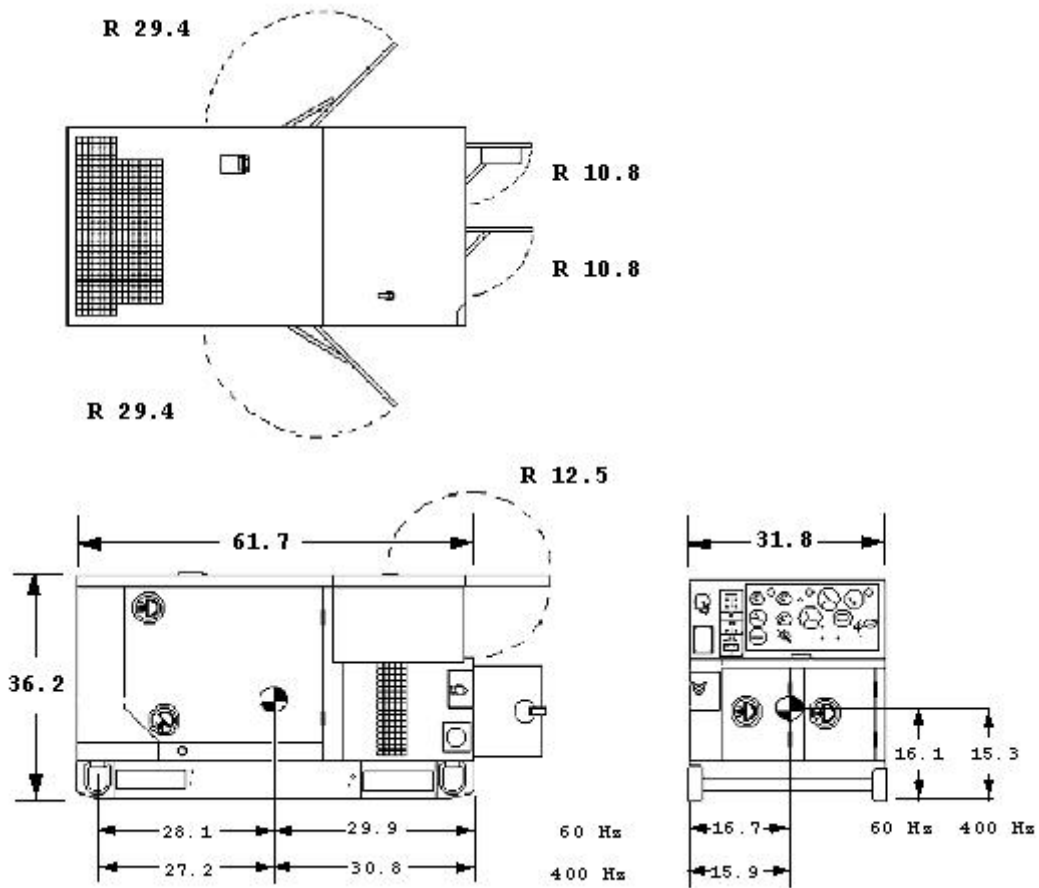
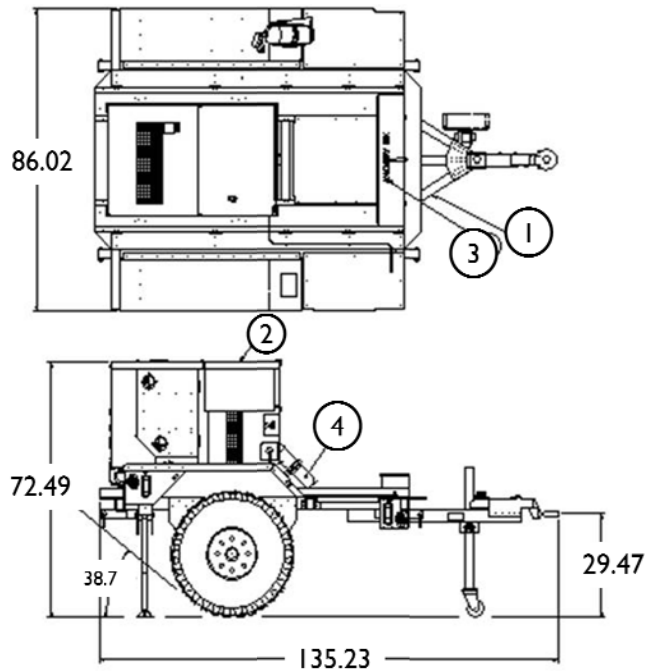

Figure A-9 10 kW Tactical Quiet Generator set

MIL-HDBK-633A  
APPENDIX A  
10 kW TQ Power Unit, 60 Hz, TRLMTD

Identification Data					
Description	10 kW TQ POWER UNIT, 60 Hz, TRLMTD			Camouflage: 97403-13228E1611	
<b>Model</b>	<b>NSN</b>	<b>LIN</b>	<b>SSN</b>	<b>ASSMEBLY</b>	<b>SPEC</b>
PU-798A	6115-01-413-3818	G42170	R62700	TA-13230E6530	
Technical Manual	Operator, Unit and Direct Support			TM 9-6115-660-13&P	
Physical Characteristics					
<b>Dimensions LWH (in) &amp; (Cube) (ft<sup>3</sup>)</b>		<b>Ship Cube (ft<sup>3</sup>)</b>		<b>Wet Weight (lbs)</b>	<b>Ship Weight (lbs)</b>
135 x 86 x 72 & (483)		483		2554	2480



FIND	COMPONENT	QTY	IDENTIFIER
1	Light Tactical Trailer (LTT) (PU-798A)	1	97403-13230E6565
2	TQ Generator set, DED, 10 kW, 60 Hz, MEP-803A	1	6115-01-275-5061
3	Accessory box	1	97403-13229E7946
4	Fire extinguisher, 5 lb., A-A-1106	1	4210-00-270-4512

Figure A-10 PU-798A

MIL-HDBK-633A  
 APPENDIX A  
 10 kW TQ Power Unit, 400 Hz, TRLMTD

Identification Data					
Description	10 kW TQ POWER UNIT, 400 Hz, TRLMTD			Camouflage: 97403-13228E1611	
<b>Model</b>	<b>NSN</b>	<b>LIN</b>	<b>SSN</b>	<b>ASSEMBLY</b>	<b>SPEC</b>
PU-799A	6115-01-413-3819	G53403	R62700	TA-13230E6540	
Technical Manual	Operator, Unit and Direct Support			TM 9-6115-660-13&P	
Physical Characteristics					
<b>Dimensions LWH (in) and (Cube) (ft<sup>3</sup>)</b>		<b>Ship Cube (ft<sup>3</sup>)</b>		<b>Wet Weight (lbs)</b>	<b>Ship Weight (lbs)</b>
135 x 86 x 72 & (483)		483		2585.	2510

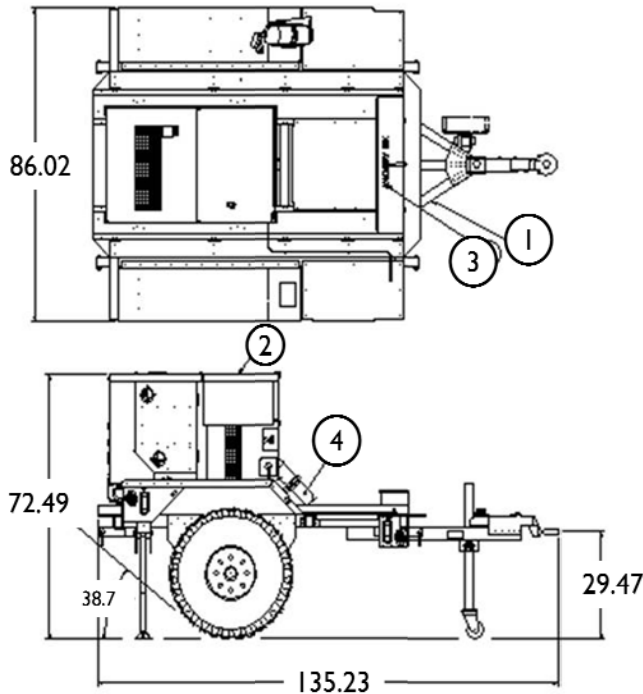

FIND	COMPONENT	QTY	IDENTIFIER
1	Light Tactical Trailer (LTT) (PU-799A)	1	7403-13230E6565
2	TQ Generator set, DED, 10 kW, 400 Hz, MEP-813A	1	6115-01-274-7392
3	Accessory box	1	97403-13229E7946
4	Fire extinguisher, 5 lb., A-A-1106	1	4210-00-270-4512

Figure A-11 PU-799A

MIL-HDBK-633A

APPENDIX A

10 kW TQ Power Plant, 60 Hz, TRLMTD

Identification Data					
Description	10 kW TQ POWER PLANT, 60 Hz, TRLMTD			Camouflage: 97403-13228E1612	
<b>Model</b>	<b>NSN</b>	<b>LIN</b>	<b>SSN</b>	<b>ASSEMBLY</b>	<b>SPEC</b>
PP-AN/MJQ-37	6115-01-299-6035	P42262	R62700	TA-13229E5670	MIL-P-53132/6
Technical Manual	Operator, Unit and Direct Support			TM 9-6115-660-13&P	
Physical Characteristics					
<b>Dimensions LWH (in) &amp; (Cube) (ft<sup>3</sup>)</b>		<b>Ship Cube (ft<sup>3</sup>)</b>		<b>Wet Weight (lbs)</b>	<b>Ship Weight (lbs)</b>
165 x 83 x 71 & (554)		554		4334	4540

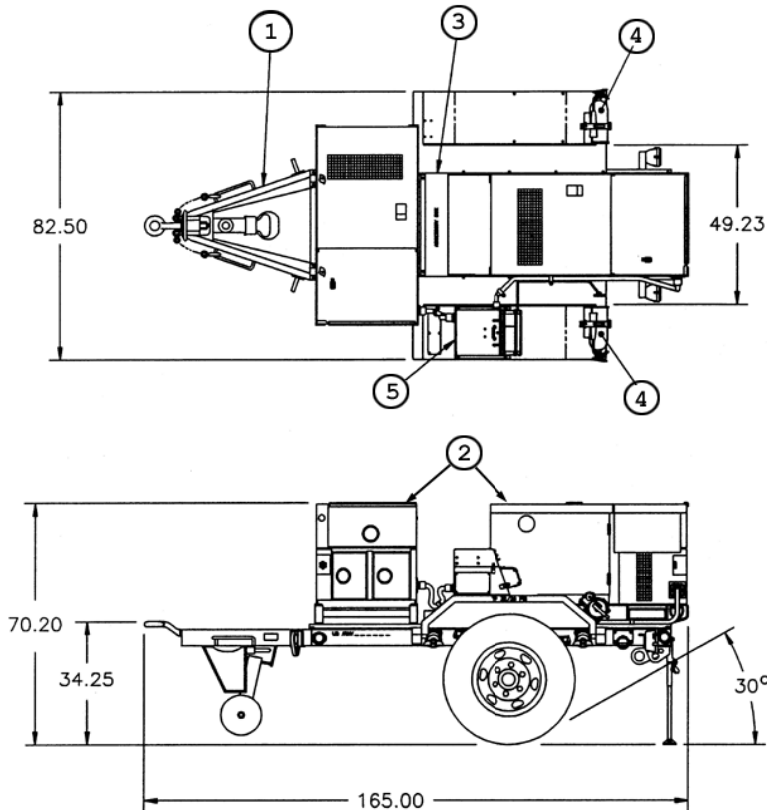

FIND	COMPONENT	QTY	IDENTIFIER
1	1-1/2 Ton modified trailer, M103A3	1	97403-13229E5825
2	TQ Generator set, DED, 10 kW, 60 Hz, MEP-803A	2	6115-01-275-5061
3	Accessory box	1	97403-13229E7946
4	Fire extinguisher, 5 lb., A-A-1106	2	4210-00-270-4512
5	Switch box	1	97403-13230E6535

Figure A-12 PP-AN/MJQ-37



MIL-HDBK-633A

APPENDIX A

## 10 kW TQ Power Plant, 400 Hz, TRLMTD

Identification Data					
Description	10 kW TQ POWER PLANT, 400 Hz, TRLMTD			Camouflage: 97403-13228E1612	
<b>Model</b>	<b>NSN</b>	<b>LIN</b>	<b>SSN</b>	<b>ASSEMBLY</b>	<b>SPEC</b>
PP-AN/MJQ-38	6115-01-313-4214	P42330	R62700	TA-13229E5680	MIL-P-53132/7
Technical Manual	Operator, Unit and Direct Support			TM 9-6115-660-13&P	
Physical Characteristics					
<b>Dimensions LWH (in) &amp; (Cube) (ft<sup>3</sup>)</b>	<b>Ship Cube (ft<sup>3</sup>)</b>		<b>Wet Weight (lbs)</b>	<b>Ship Weight (lbs)</b>	
165 x 83 x 71 & (562)	562		4500	4350	

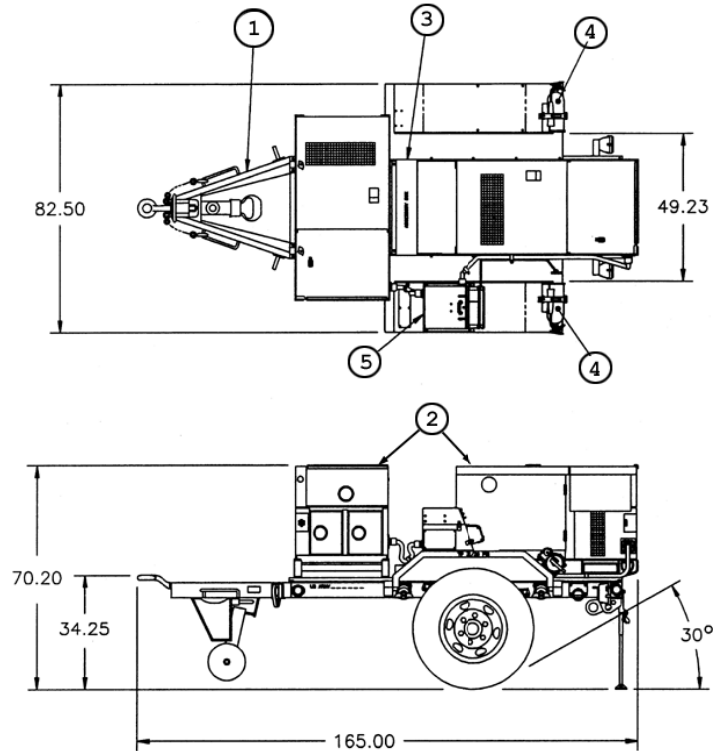

FIND	COMPONENT	QTY	IDENTIFIER
1	1-1/2 Ton modified trailer, M103A3	1	97403-13229E5825
2	TQ Generator set, DED, 10 kW, 400 Hz, MEP-813A	2	6115-01-274-7392
3	Accessory box	1	97403-13229E7946
4	Fire extinguisher, 5 lb., A-A-1106	1	4210-00-270-4512
5	Switch box	1	97403-13230E6535

Figure A-13 PP-AN/MJQ-38

## MIL-HDBK-633A

## APPENDIX A

## 15 kW Tactical Quiet Generator Set (TQG)

Identification Data				
Description	15 kW TQG, 50/60 Hz, DED, Skid Mtd		15 kW, TQG, 400 Hz, DED, Skid Mtd	
Model	MEP-804A MEP-804B		MEP-814A MEP-814B	
NSN	6115-01-274-7388		6115-01-274-7393	
Re-Engine	B model 6115-01-530-1458		B model 6115-01-529-9494	
LIN	G12170 B model G12170		G12238 B model G12238	
Specification	MIL-DTL-53133/5		MIL-DTL-53133/6	
SSN	M53500		M53500	
Trailer mounted configurations	PU-801B: <a href="#">Figure A-16</a> PU-802A: <a href="#">Figure A-17</a> PP-AN/MJQ-48B: <a href="#">Figure A-19</a>		PU-800A: <a href="#">Figure A-15</a> PP-AN/MJQ-39B: <a href="#">Figure A-18</a>	
Physical Characteristics				
Dimensions LWH (in)	70 x 36 x 55 (Cube: 77 ft <sup>3</sup> )			
Wet Weight (lbs)	2124	2238		
Engine	Yanmar - Model:4TNV84T-DFM 4 Cycle, Liquid Cooled, 4 Cyl, 3.31 Inch Bore, 40 BHP @ 1800 RPM, 24 VDC starter,			
Instrumentation	Hour meter, voltmeter, frequency, amps (% RL), oil pressure, fuel, coolant temp, battery amps, emergency stop, battle short.			
Fuels	Diesel DL-1, DL-2; Jet Fuel JP-8.			
Fuel Capacity	Fuel tank: 14 gallons.			
Performance Characteristics				
Power Rating	15 kW (12.5 kW @ 50 Hz), 0.8 pf @ 4000 ft/120 °F; 110% Max Power; De-rate: 3.5%/1000 ft from 4000 to 8000 ft			
Environmental Capability	-25°F (-50°F W/kit) to 125°F, rain, humidity, altitude, sand/dust, transportation, cold storage: -60°F, salt spray, fungus, 15° incline.			
Protective Devices	Automatic shut down with emergency bypass for low oil pressure, coolant high-temperature, no fuel, over-speed, and over-voltage.			
Fuel Consumption	1.44 gph @ rated load.	1.75 gph @ rated load.		
Human Factors	MIL-STD-1474.			
Noise	70 dBA @ 7 meters (23 ft).			
Reliability (MTBF)	594 hr @ 80% LCL	377 hr @ 80% LCL		
Maintenance Ratio	less than 0.05			
Electrical Characteristics				
Connection	120/208V, 3ph, 4 wire	240/416V, 3ph, 4 wire	Freq adj range	
Volt adj range (50Hz)	190 – 213 V	380 – 426 V	48 - 52 Hz	
Volt adj range (60Hz)	197 - 240 V	395 - 480 V	58 - 62 Hz	
Volt adj range (400Hz)	197 - 229 V	395 - 458 V	390 - 420 Hz	
Electrical	Drip proof generator enclosure, fungus & moisture treated, solid state voltage regulator, solderless connectors, brushless Marathon/Lima generator.			
Electrical Performance				
Electric Power Quality	AC Voltage		Frequency	
	50/60 Hz	400 Hz	50/60 Hz	400 Hz
Regulation	1%		0.25%	
Modulation	1%			
Short term steady st stability (30 sec)	1% bandwidth		0.5% bandwidth	
Long term steady state stability (4 hr)	2% bandwidth		1% bandwidth	
Application/rejection of rated load, Recovery time	15% dip/rise, 0.5 sec	12% dip/rise, 0.5 sec	4% und/ over, 2 sec	1.5%und/over, 1 sec
Motor load	30% dip, .7 sec to 95% init volt	25% dip,.7 sec to 95% init volt		
Max waveform deviation factor	5%			
Individual waveform harmonic	2%			
EMI	Meets MIL-STD-461C Part 9			
EMP	HAEMP IAW MIL-STD-2169			

MIL-HDBK-633A  
APPENDIX A

Optional Equipment			
Description	NSN	Tech Bulletin	Effect on Dimensions (in)
Winterization kit	6115-01-477-0566	TB 9-6115-643-13	None (internal)
Technical Manuals			
	Army	Air Force	Marine Corps
Operators	TM 9-6115-643-10	TO 35C2-3-455-21	None
Unit, DS, GS	TM 9-6115-643-24	TO 35C2-3-455-22	
RPSTL	TM 9-6115-643-24P	TO 35C2-3-455-24	
Engine Maintenance	TM 9-2815-254-24	TO 38G1-94-2	
Engine Parts	TM 9-2815-254-24P	TO 38G1-94-4	
Lube Order	LO 9-6115-643-12		
Warranty	TB 9-6115-643-24		



MEP-804A, MEP-804B, MEP-814A or MEP-814B

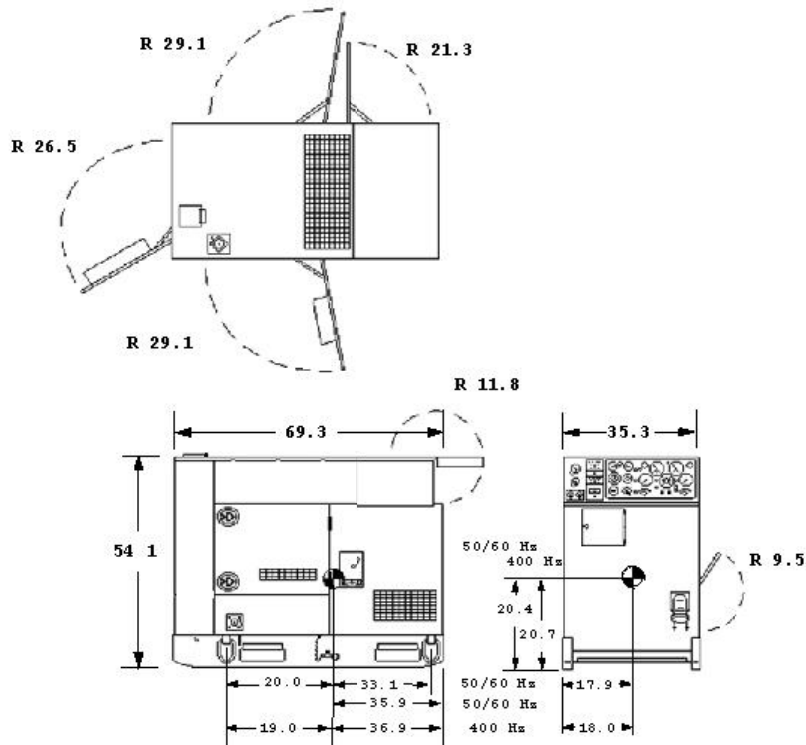
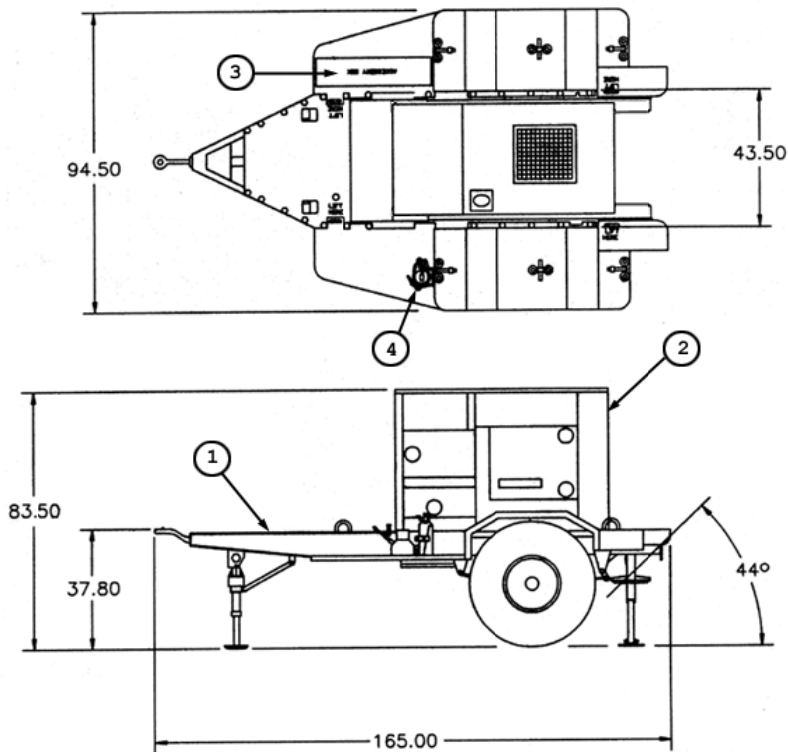

Figure A-14 15 kW Tactical Quiet Generator Set-

MIL-HDBK-633A  
 APPENDIX A  
 15 kW TQ Power Unit, 400 Hz, TRLMTD

Identification Data					
Description	15 kW TQ POWER UNIT, 400 Hz, TRLMTD			Camouflage: 97403-13228E1614	
<b>Model</b>	<b>NSN</b>	<b>LIN</b>	<b>SSN</b>	<b>ASSEMBLY</b>	<b>SPEC</b>
PU-800A	6115-01-565-0929	G78203	R62700	TA-97-2111	MIL-P-53132
Technical Manual	Operator, Unit and Direct Support			TM 9-6115-661-13&P	
Physical Characteristics					
<b>Dimensions LWH (in) &amp; (Cube) (ft<sup>3</sup>)</b>		<b>Ship Cube (ft<sup>3</sup>)</b>		<b>Wet Weight (lbs)</b>	<b>Ship Weight (lbs)</b>
165 x 95 x 84 & (761)		761		4975	4855



FIND	COMPONENT	QTY	IDENTIFIER
1	2 1/2 Ton modified Trailer, M200A1	1	97403-13229E9623
2	TQ Generator set, DED, 15 kW, 400 Hz, MEP-814B	1	6115-01-274-7393
3	Accessory box	1	97403-13229E7946
4	Fire extinguisher, 5 lb., A-A-1106	1	4210-00-270-4512

Figure A-15 PU-800A

MIL-HDBK-633A  
 APPENDIX A  
 15 kW TQ Power Unit, 50/60 Hz, TRLMTD

Identification Data					
Description	15 kW TQ POWER UNIT, 50/60 Hz, TRLMTD			Camouflage: 97403-13228E1613	
<b>Model</b>	<b>NSN</b>	<b>LIN</b>	<b>SSN</b>	<b>ASSEMBLY</b>	<b>SPEC</b>
PU-801B	6115-01-565-0874	G78374	R62700	TA-97-2003	MIL-P-53132/12
Technical Manual	Operator, Unit and Direct Support			TM 9-6115-661-13&P	
Physical Characteristics					
<b>Dimensions LWH (in) &amp; (Cube) (ft<sup>3</sup>)</b>		<b>Ship Cube (ft<sup>3</sup>)</b>		<b>Wet Weight (lbs)</b>	<b>Ship Weight (lbs)</b>
135 x 86 x 91 & (611)		611		3516	3400

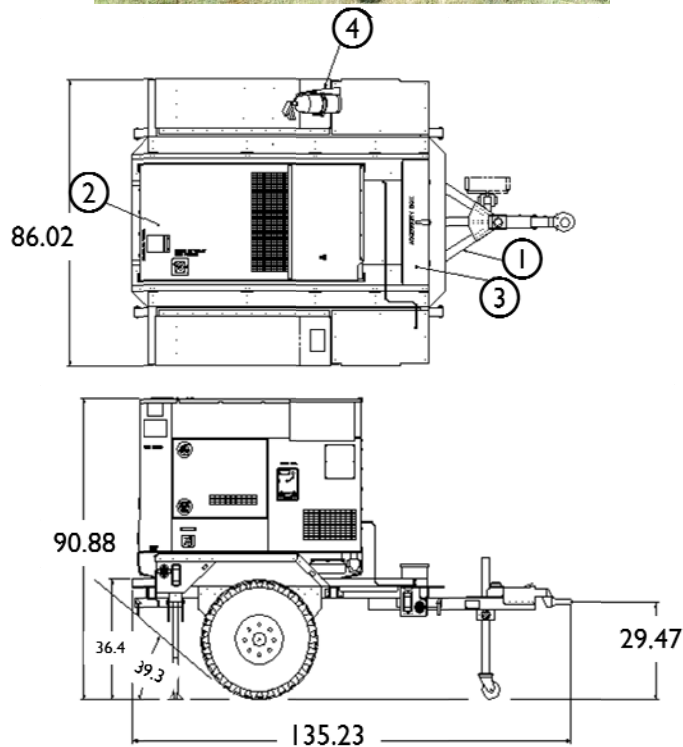

FIND	COMPONENT	QTY	IDENTIFIER
1	Light Tactical Trailer (LTT) (PU-801B)	1	97403-13230E6565
2	TQ Generator Set, DED, 15 kW, 50/60 Hz, MEP-804B	1	6115-01-274-7388
3	Accessory box	1	97403-13229E7946
4	Fire extinguisher, 5 lb., A-A-1106	1	4210-00-270-4512

Figure A-16 PU-801B

MIL-HDBK-633A

APPENDIX A

15 kW TQ Power Unit, 50/60 Hz, TRLMTD

Identification Data					
Description	15 kW TQ POWER UNIT, 50/60 Hz, TRLMTD			Camouflage: 97403-13228E1614	
<b>Model</b>	<b>NSN</b>	<b>LIN</b>	<b>SSN</b>	<b>ASSEMBLY</b>	<b>SPEC</b>
PU-802A	6115-01-565-1576	G53778	R62700	TA-97-2101	MIL-P-53132/13
Technical Manual	Operator, Unit and Direct Support			TM 9-6115-661-13&P	
Physical Characteristics					
<b>Dimensions LWH (in) &amp; (Cube) (ft<sup>3</sup>)</b>		<b>Ship Cube (ft<sup>3</sup>)</b>		<b>Wet Weight (lbs)</b>	<b>Ship Weight (lbs)</b>
165 x 95 x 84 & (754)		754		5040	4920

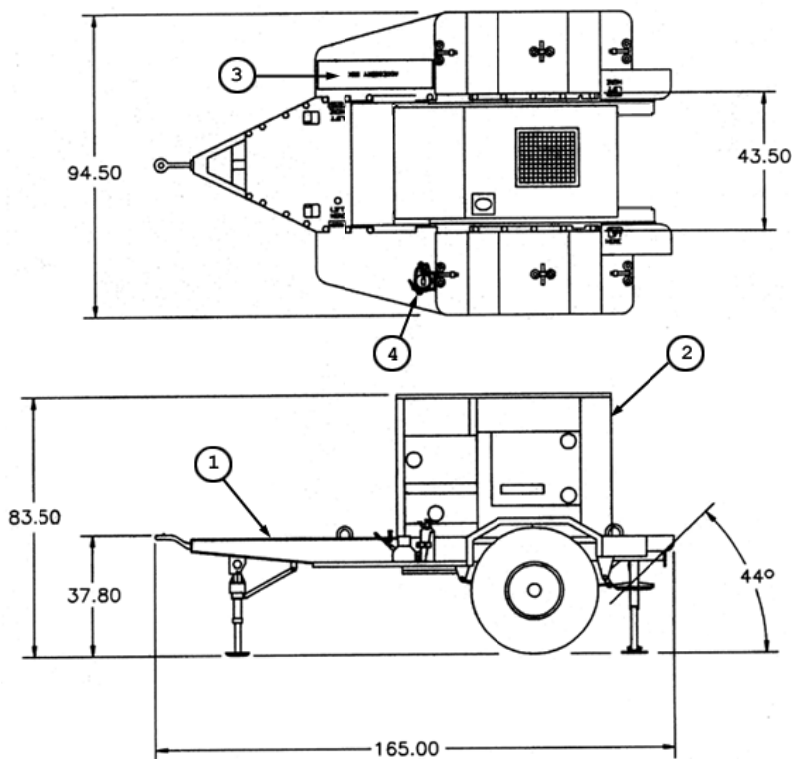

FIND	COMPONENT	QTY	IDENTIFIER
1	2-1/2 Ton modified trailer, M200A1	1	97403-13229E9632
2	TQ Gen set, DED, 15 kW, 50/60 Hz, MEP-804B	1	6115-01-274-7388
3	Accessory box	1	97403-13229E7946
4	Fire extinguisher, 5 lb., A-A-1106	1	4210-00-270-4512

Figure A-17 PU-802A

MIL-HDBK-633A

APPENDIX A

15 kW TQ Power Plant, 400 Hz, TRLMTD

Identification Data					
Description	15kW TQ POWER PLANT, 400 Hz, TRLMTD			Camouflage: 97403-13228E1614	
<b>Model</b>	<b>NSN</b>	<b>LIN</b>	<b>SSN</b>	<b>ASSEMBLY</b>	<b>SPEC</b>
PP-ANMJQ-39B	6115-01-565-0701	P42614	R62700	TA-97-3104	MIL-P-53132
Technical Manual	Operator, Unit and Direct Support			TM 9-6115-661-13&P	
Physical Characteristics					
<b>Dimensions (LWH (in)) &amp; (Cube) (ft<sup>3</sup>)</b>	<b>Ship Cube (ft<sup>3</sup>)</b>		<b>Wet Weight (lbs)</b>		<b>Ship Weight (lbs)</b>
165 x 95 x 84 & (754) each	754 each		Unit A: 4863 Unit B: 4893		Unit A: 4765 Unit B: 4765

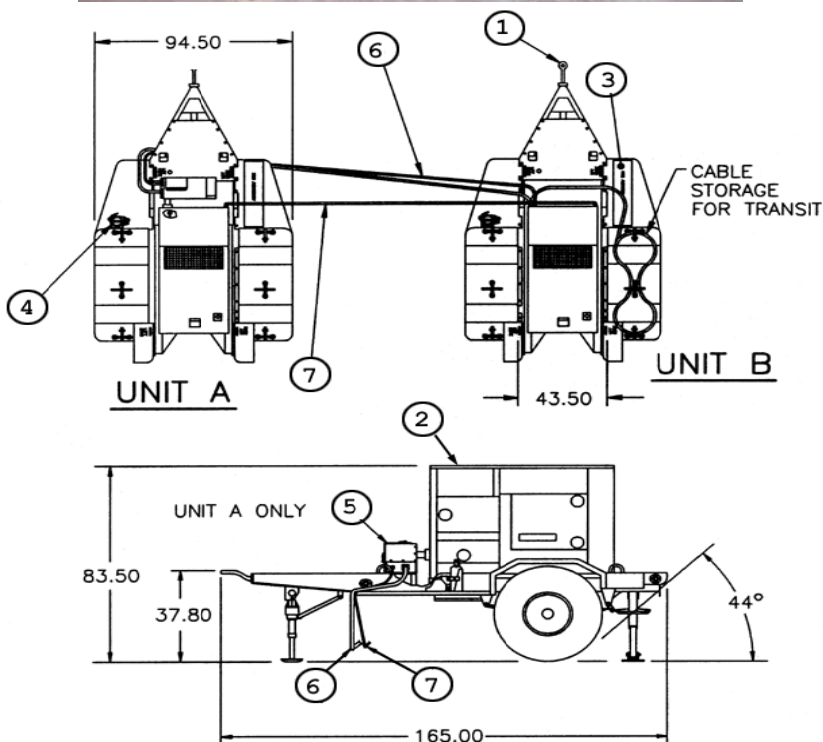

FIND	COMPONENT	QTY	IDENTIFIER
1	2-1/2 Ton modified trailer, M200A1	2	97403-13229E9632
2	TQ Gen set, DED, 15 kW, 400 Hz, MEP-814B	2	6115-01-529-9494
3	Accessory box	2	97403-13229E7946
4	Fire extinguisher, 5 lb., A-A-1106	2	4210-00-270-4512
5	Switch box (unit A)	1	97403-13229E5795-1
6	Cable assembly (unit B)	1	97403-13229E5674
7	Paralleling cable assembly,	2	30554-88-22209

Figure A-18 PP-AN/MJQ-39B

MIL-HDBK-633A

APPENDIX A

## 15 kW TQ Power Plant, 50/60 Hz, TRLMTD

Identification Data					
Description	15kW TQ POWER PLANT, 50/60 Hz, TRLMTD			Camouflage: 97403-13228E1728	
<b>Model</b>	<b>NSN</b>	<b>LIN</b>	<b>SSN</b>	<b>ASSEMBLY</b>	<b>SPEC</b>
PP-AN/MJQ-48B	6115-01-565-0691	Z01012	R62700	TA-97-3003	MIL-P-53132
Technical Manual	Operator, Unit and Direct Support			TM 9-6115-661-13&P	
Physical Characteristics					
<b>Dimensions (LWH (in)) &amp; (Cube) (ft<sup>3</sup>)</b>		<b>Ship Cube (ft<sup>3</sup>)</b>		<b>Wet Weight (lbs)</b>	<b>Ship Weight (lbs)</b>
135 x 86 x 91 & (611) each		611 each		Unit A: 3570 Unit B: 3570	Unit A: 3470 Unit B: 3470

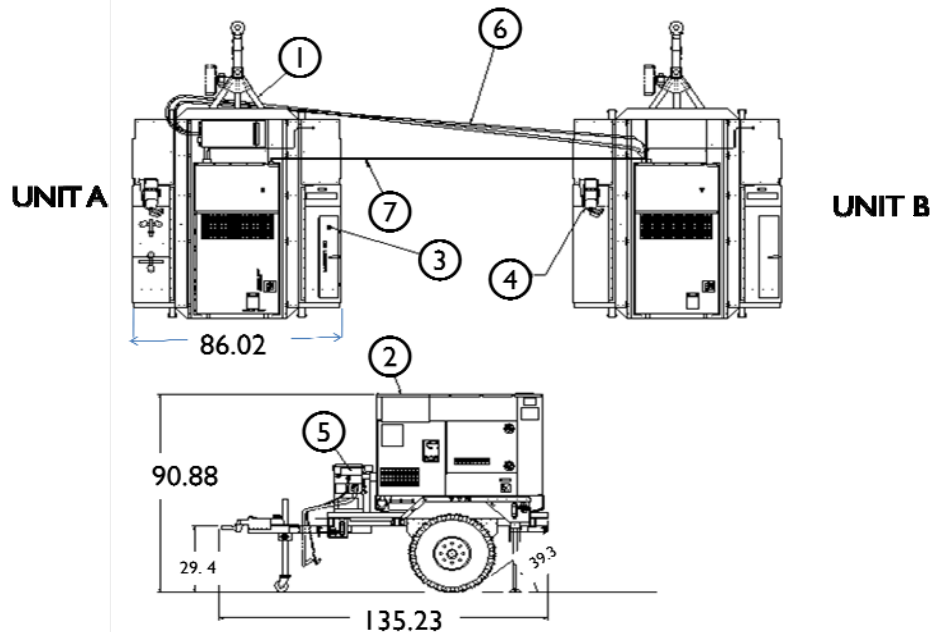

FIND	COMPONENT	QTY	IDENTIFIER
1	Light Tactical Trailer (LTT) AN/MJQ-48A	2	97403-13230E6565
2	TQ Gen set, DED, 15 kW, 50/60 Hz, MEP-804A	2	6115-01-274-7388
3	Accessory box	2	97403-13229E7946
4	Fire extinguisher, 5 lb., A-A-1106	2	4210-00-270-4512
5	Switch box (unit A)	1	97403-13229E5795-1
6	Cable assembly (unit B)	1	97403-13229E5674
7	Paralleling cable assembly,	2	30554-88-22209

Figure A-19 PP-AN/MJQ-48B



MIL-HDBK-633A  
APPENDIX A

This Page Intentionally Left Blank

## MIL-HDBK-633A

## APPENDIX A

## 30 kW Tactical Quiet Generator Set (TQG)

Identification Data				
Description	30 kW TQG, 50/60 Hz, DED, Skid Mtd		30 kW TQG, 400 Hz, DED, Skid Mtd	
Model	MEP-805B		MEP-815B	
NSN	6115-01-461-9335		6115-01-462-0290	
LIN	G74575		G74643	
Specification	MIL-DTL-53133/7		MIL-DTL-53133/8	
SSN	M53500		M53500	
Trailer mounted configurations	PU-803B, <a href="#">Figure A-21</a> PP-AN/MJQ-40B, <a href="#">Figure A-23</a>		PU-804B, <a href="#">Figure A-22</a>	
Physical Characteristics				
Dimensions LWH (in)	80 x 36 x 55 (Cube: 88 ft <sup>3</sup> )			
Wet Weight (lbs)	3040		3060	
Engine	John Deere - Model: 4045TF151 4 cyl Turbo Diesel, 92 hp @ 1800 RPM, 24 VDC starter, liquid cooled. EPA certified.			
Instrumentation	Digital Display			
Fuels	Diesel DL-1, DL-2; Jet Fuel JP-8. Fuel tank: 23 gallons.			
Performance Characteristics				
Power Rating	30 kW (25 kW @ 50 Hz), 0.8 pf @ 4000 ft/120°F; 110% Max Power; De-rate: 3.5%/1000 ft from 4000 to 8000 ft			
Environmental Capability	-25°F (-50°F W/kit) to 125°F, rain, humidity, altitude, sand/dust, transportation, cold storage: -60°F, salt spray, fungus, 15° incline.			
Protective Devices	Automatic shut down with emergency bypass for low oil pressure, coolant high temperature, low fuel, over-speed, and over-voltage.			
Fuel Consumption	2.7 gph @ rated load.		3.0 gph @ rated load.	
Human Factors	MIL-STD-1474			
Noise	70 dBA @ 7 meters (23 ft).			
Reliability (MTBF)	1638 hr @ 80% LCL		679 hr @ 80% LCL	
Maintenance Ratio	less than 0.05			
Other	Remote Control Capable			
Electrical Characteristics				
Connection	120/208V, 3ph, 4 wire	240/416V, 3ph, 4 wire	Frequency adj range	
Volt adj range (50Hz)	190 – 213 V	380 – 426 V	48 - 52 Hz	
Volt adj range (60Hz)	197 - 240 V	395 - 480 V	58 - 62 Hz	
Volt adj range (400Hz)	197 - 229 V	395 - 458 V	390 - 410 Hz	
Electrical	Drip proof generator enclosure, fungus & moisture treated, solid state voltage regulator, solderless connectors, Marathon Electric synchronous rotating field generator.			
Electrical Performance				
Electric Power Quality	AC Voltage		Frequency	
	50/60 Hz	400 Hz	50/60 Hz	400 Hz
Regulation	1%		0.25%	
Modulation	1%			
Short term steady state stability (30 sec)	1% bandwidth		0.5% bandwidth	
Long term steady state stability (4 hr)	2% bandwidth		1% bandwidth	
Application./rejection of rated load, recovery time	15% dip/rise , 0.5 sec	12% dip/rise, 0.5 sec	4% und/over 2 sec	1.5%und/over 1 sec
Motor load	30% dip, .7 sec to 95% init volt	30% dip, .7 sec to 95% init volt		
Max waveform deviation factor	5%			
Individual waveform harmonic	2%			
EMI	Meets MIL-STD-461C, Part 9			
EMP	HAEMP IAW MIL-STD-2169			
Optional Equipment				
Description	NSN	Tech Bulletin	Effect on Dimensions (in)	
Winterization kit	6115-01-474-8354	TB9-6115-644-13	None (internal)	

MIL-HDBK-633A  
APPENDIX A

Technical Manuals			
	ARMY	Air Force	Marine Corps
Operators, DS, GS	TM 9-6115-671-14	TO 35C2-3-446-32	TM 09249A/09246A-14
RPSTL	TM 9-6115-671-24P	TO 35C2-3-446-34	TM 09249A/09246A-24P/3
Engine Maintenance	TM 9-2815-259-24	TO 38BG1-125-2	TM 09249A/09246A-24
Engine Parts	TM 9-2815-259-24P	TO 38BG1-125-4	TM 09249A/2815-24P/4
Lube Order	LO 9-6115-644-12		
Warranty	TB 9-6115-671-24		



MEP-805B or MEP-815B

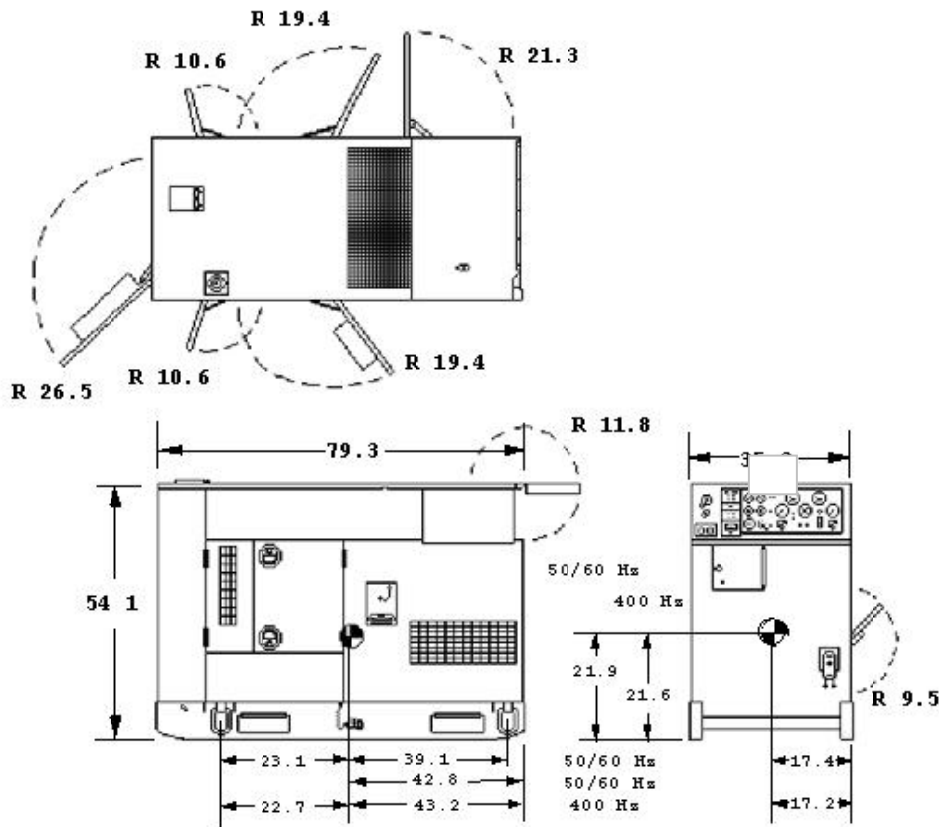

Figure A-20 30 kW Tactical Quiet Generator Set (re-engine)

MIL-HDBK-633A

APPENDIX A

30 kW TQ Power Unit, 50/60 Hz, TRLMTD

Identification Data					
Description	30 kW TQ POWER UNIT, 50/60 Hz, TRLMTD			Camouflage: 97403-13228E1615	
<b>Model</b>	<b>NSN</b>	<b>LIN</b>	<b>SSN</b>	<b>ASSEMBLY</b>	<b>SPEC</b>
PU-803B	6115-01-470-6376	G35851	R62700	TA-13230E6849	MIL-P-53132/15
Technical Manual	Operator, Unit and Direct Support			TM 9-6115-662-13&P	
Physical Characteristics					
<b>Dimensions LWH (in) &amp; (Cube) (ft<sup>3</sup>)</b>	<b>Ship Cube (ft<sup>3</sup>)</b>		<b>Wet Weight (lbs)</b>	<b>Ship Weight (lbs)</b>	
165 x 95 x 85 & (763)	763		5525	5320	

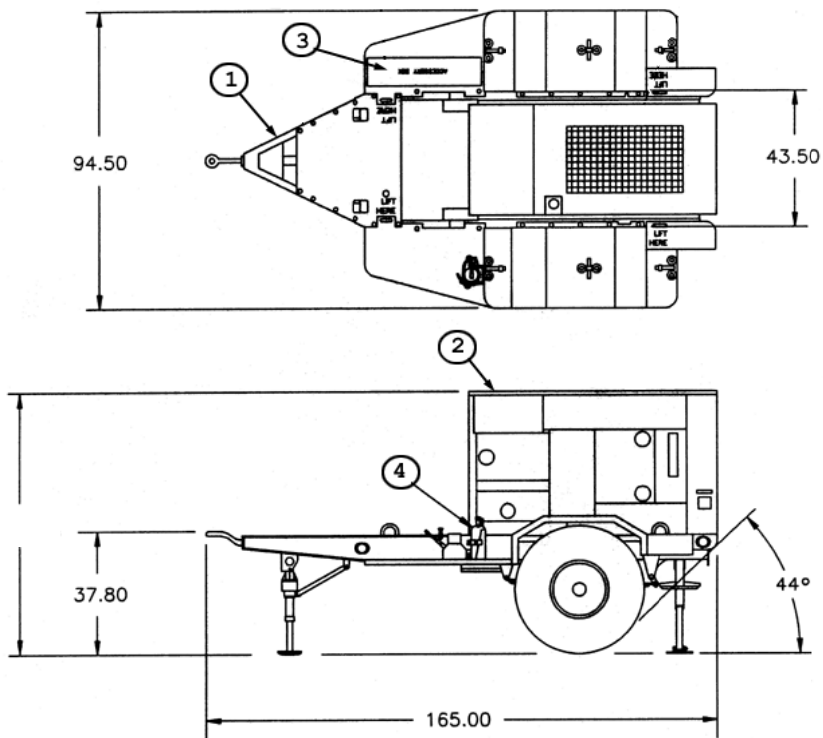

FIND	COMPONENT	QTY	IDENTIFIER
1	2-1/2 Ton modified trailer, M200A1	1	97403-13229E9632
2	TQ Gen set, DED, 30 kW, 50/60 Hz, MEP-805B	1	6115-01-461-9335
3	Accessory box	1	97403-13229E7946
4	Fire extinguisher, 5 lb., A-A-1106	1	4210-00-270-4512

Figure A-21 PU-803B

MIL-HDBK-633A  
 APPENDIX A  
 30 kW TQ Power Unit, 400 Hz, TRLMTD

Identification Data					
Description	30 kW TQ POWER UNIT, 400 Hz, TRLMTD			Camouflage: 97403-13228E1615	
<b>Model</b>	<b>NSN</b>	<b>LIN</b>	<b>SSN</b>	<b>ASSEMBLY</b>	<b>SPEC</b>
PU-804B	6115-01-471-1507	G35919	R62700	TA-13230E6850	MIL-P-53132/16
Technical Manual	Operator, Unit and Direct Support			TM 9-6115-662-13&P	
Physical Characteristics					
<b>Dimensions LWH (in) &amp; (Cube) (ft<sup>3</sup>)</b>		<b>Ship Cube (ft<sup>3</sup>)</b>		<b>Wet Weight (lbs)</b>	<b>Ship Weight (lbs)</b>
165 x 95 x 85 & (763)		763		5545	5340

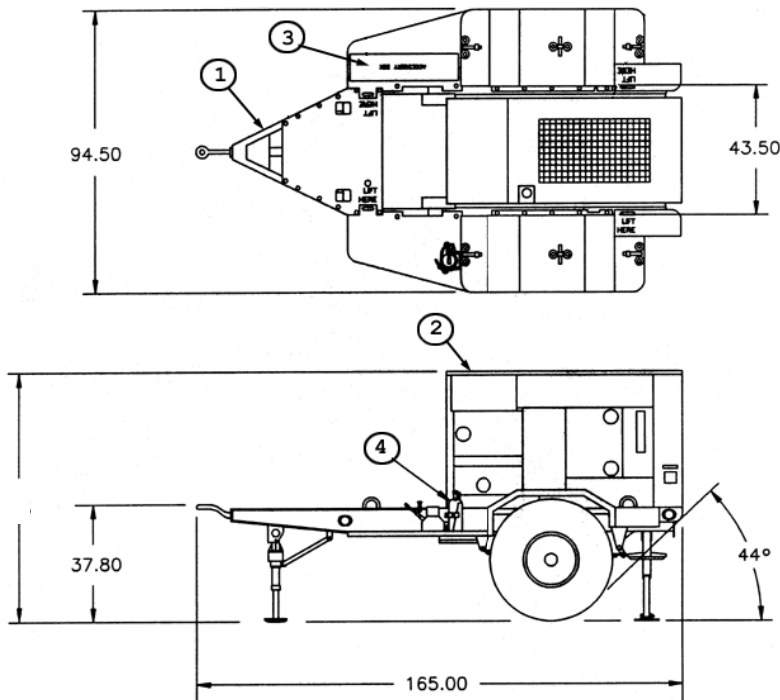

FIND	COMPONENT	QTY	IDENTIFIER
1	2-1/2 Ton modified trailer, M200A1	1	97403-13229E9632
2	TQ Generator set, DED, 30 kW, 400 Hz, MEP-815B	1	6115-01-462-0290
3	Accessory box	1	97403-13229E7946
4	Fire extinguisher, 5 lb., A-A-1106	1	4210-00-270-4512

Figure A-22 PU-804B

MIL-HDBK-633A

APPENDIX A

## 30 kW TQ Power Plant, 50/60 Hz, TRLMTD

Identification Data					
Description	30 kW TQ POWER PLANT, 50/60 Hz, TRLMTD			Camouflage: 97403-13228E1615	
<b>Model</b>	<b>NSN</b>	<b>LIN</b>	<b>SSN</b>	<b>ASSEMBLY</b>	<b>SPEC</b>
PP-AN/MJQ-40B	6115-01-474-3783	P42126	R62700	TA-13230E6853	MIL-P-53132/14
Technical Manual	Operator, Unit and Direct Support			TM 9-6115-662-13&P	
Physical Characteristics					
<b>Dimensions LWH (in) &amp; (Cube) (ft<sup>3</sup>)</b>	<b>Ship Cube (ft<sup>3</sup>)</b>		<b>Wet Weight (lbs)</b>	<b>Ship Weight (lbs)</b>	
165 x 95 x 85 & (763) each	763 each		Unit A: 5590 Unit B: 5590	Unit A: 5390 Unit B: 5390	

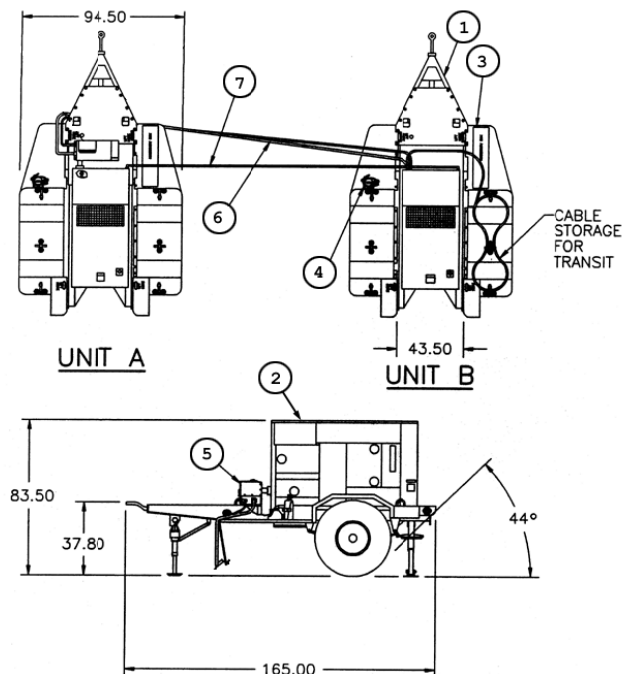

FIND	COMPONENT	QTY	IDENTIFIER
1	2-1/2 Ton modified trailer, M200A1	2	97403-13229E9632
2	TQ Generator set, DED, 30kW, 50/60 Hz, MEP-805B	2	6115-01-461-9335
3	Accessory box	2	97403-13229E7946
4	Fire extinguisher, 5 lb., A-A-1106	2	4210-00-270-4512
5	Switch box (unit A)	1	97403-13229E5795-2
6	Cable assembly ( unit B)	1	97403-13229E5738
7	Paralleling cable assembly	2	30554-88-22209

Figure A-23 PP-AN/MJQ-40B

MIL-HDBK-633A  
APPENDIX A

This Page Intentionally Left Blank

## MIL-HDBK-633A

## APPENDIX A

## 60 kW Tactical Quiet Generator Set (TQG)

Identification Data				
Description	60 kW TQG, 50/60 Hz, DED, Skid Mtd		60 kW TQG, 400 Hz, DED, Skid Mtd	
Model	MEP-806B		MEP-816B	
NSN	6115-01-462-0291		6115-01-462-0292	
LIN	G12034		G18052	
Specification	MIL-DTL-53133/9		MIL-DTL-53133/10	
SSN	M53500		M53500	
Trailer mounted configurations	PU-805B, <a href="#">Figure A-25</a> ; PP-AN/MJQ-41B, <a href="#">Figure A-27</a> ; PP-AN/MJQ-1612B, <a href="#">Figure A-28</a>		PU-806B, <a href="#">Figure A-26</a> PP-AN/MJQ-1632B, <a href="#">Figure A-29</a>	
Physical Characteristics				
Dimensions LWH (in)	87 x 36 x 59 (Cube: 106 ft <sup>3</sup> )			
Wet Weight (lbs)	4200	4240		
Engine	John Deere 6068T151 6 cylinder, 4 cycle Turbo Diesel, 134 horsepower @ 1800 RPM, 24 VDC starter, liquid cooled, electronic governor. EPA certified			
Instrumentation	Digital controls			
Fuels	Diesel DL-1, DL-2; Jet Fuel JP-8. Fuel tank: 43 gallons.			
Performance Characteristics				
Power Rating	60kW (50kW @ 50Hz), 0.8 pf@ 4000ft/120°F; 110% Max Power; De-rate: 3.5%/1000ft fm 4000 - 8000ft			
Environmental Capability	-25°F (-50°F With Winterization Kit) to 125°F, rain, humidity, altitude, sand/dust, transportation, cold storage: -60°F, salt spray, fungus, 15° incline.			
Protective Devices.	Automatic shut down with emergency bypass for low oil pressure, coolant high-temperature, low fuel, over-speed, and over-voltage			
Fuel Consumption	4.7 gph @ rated load.	4.9 gph @ rated load.		
Human Factors	MIL-STD-1474.			
Noise	70 dBA @ 7 meters (23 ft).			
Reliability (MTBF)	606 hr @ 80% LCL	542 hr @ 80% LCL		
Maintenance Ratio	less than 0.05			
Electrical Characteristics				
Connection	120/208V, 3ph, 4 wire	240/416V, 3ph, 4 wire	Freq adj range	
Volt adj range (50 Hz)	190 – 213 V	380 – 426 V	48 - 52 Hz	
Volt adj range (60 Hz)	197 - 240 V	395 - 480 V	58 - 62 Hz	
Volt adj range (400Hz)	197 - 229 V	395 - 458 V	390 - 410 Hz	
Electrical	Drip proof generator enclosure, fungus & moisture treated, solid state voltage regulator, solderless connectors, Marathon (60Hz)/Lim (400Hz) a brushless generator.			
Electrical Performance				
Electric Power Quality	AC Voltage		Frequency	
	50/60 Hz	400 Hz	50/60 Hz	400 Hz
Regulation	1%		0.25%	
Modulation	1%			
Short term steady state stability (30 sec)	1% bandwidth		0.5% bandwidth	
Long term steady state stability (4 hr)	2% bandwidth		1% bandwidth	
Application/rejection of rated load , recovery time	15% dip/rise 0.5 sec		4% und/over 2 sec	1.5%und/over 1 sec
Motor load	30% dip, .7 sec to 95% init volt	25% dip, .7 sec to 95% init volt		
Max waveform deviation factor	5%			
Individual waveform harmonic	2%			
EMI	Meets MIL-STD-461C Part 9			
EMP	HAEMP IAW MIL-STD-2169			
Optional Equipment				
Description	NSN	Tech Bulletin	Effect on Dimensions (in)	
Winterization kit	6115-01-496-7710	TB9-6115-645-13	None (internal)	
Technical Manuals				
Description	ARMY	Air Force	Marine Corps	
Operators, DS, GS	TM 9-6115-672-14	TO 35C2-3-444-32	TM 09244A/09245A-14	
RPSTL	TM 9-6115-672-24P	TO 35C2-3-444-34	TM 09244A/09245A-24P/3	
Engine Maintenance	TM 9-2815-260-24	TO 38G1-126-2	TM 09244A/09245-24	
Engine Parts	TM 9-2815-260-24P	TO 38G1-126-4	TM 09244A/2815-24P/4	
Lube Order	LO 9-6115-645-12			
Warranty	TB 9-6115-672-24			



MIL-HDBK-633A  
APPENDIX A



MEP-806B or MEP-816B

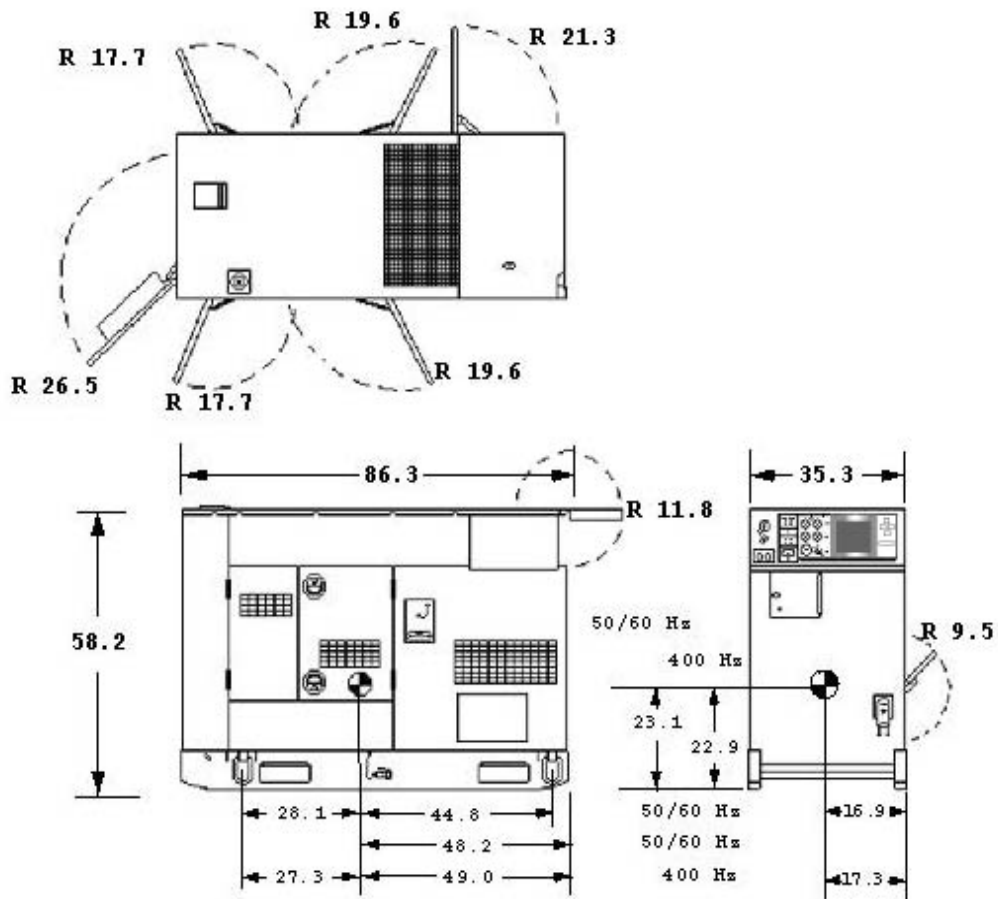

Figure A-24 60 kW Tactical Quiet Generator Set (re-engine)

MIL-HDBK-633A

APPENDIX A

## 60 kW TQ Power Unit, 50/60 Hz, TRLMTD

Identification Data					
Description	60 kW TQ POWER UNIT, 50/60 Hz, TRLMTD			Camouflage: 97403-13228E1616	
<b>Model</b>	<b>NSN</b>	<b>LIN</b>	<b>SSN</b>	<b>ASSEMBLY</b>	<b>SPEC</b>
PU-805B	6115-01-471-1508	G78306	R62700	TA-13230E6851	MIL-P-53132/18
Technical Manual	Operator, Unit and Direct Support			TM 9-6115-663-13&P	
Physical Characteristics					
<b>Dimensions LWH (in) &amp; (Cube) (ft<sup>3</sup>)</b>	<b>Ship Cube (ft<sup>3</sup>)</b>		<b>Wet Weight (lbs)</b>	<b>Ship Weight (lbs)</b>	
165 x 95 x 88 & (788)	788		6820	6460	

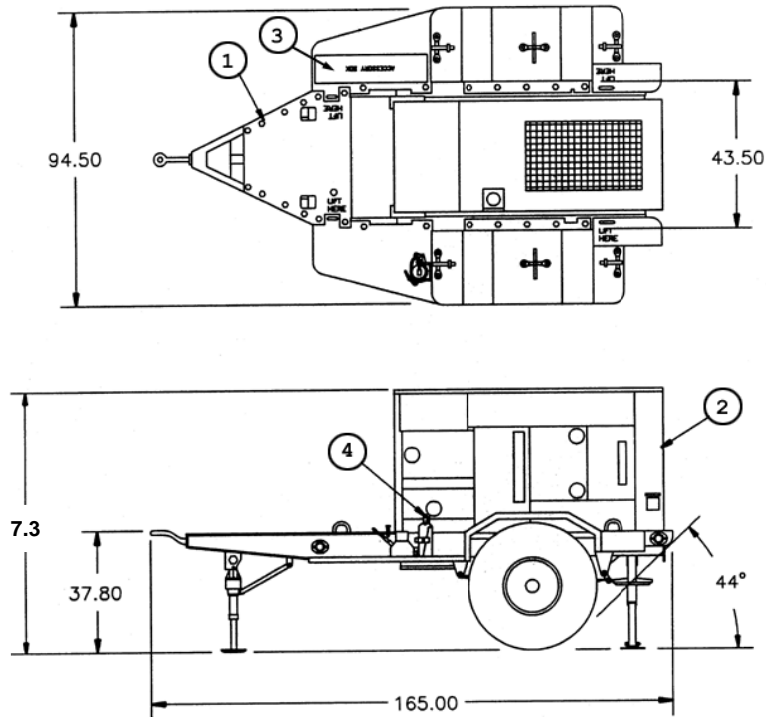

FIND	COMPONENT	QTY	IDENTIFIER
1	2-1/2 Ton modified trailer, M200A1	1	97403-13229E9632
2	TQ Gen set, DED, 60 kW, 50/60 Hz, MEP-806B	1	6115-01-462-0291
3	Accessory box	1	97403-13229E7946
4	Fire extinguisher, 5 lb., A-A-1106	1	4210-00-270-4512

Figure A-25 PU-805B

MIL-HDBK-633A  
 APPENDIX A  
 60 kW TQ Power Unit, 400 Hz, TRLMTD

Identification Data					
Description	60 kW TQ POWER UNIT, 400 Hz, TRLMTD			Camouflage: 97403-13228E1616	
<b>Model</b>	<b>NSN</b>	<b>LIN</b>	<b>SSN</b>	<b>ASSEMBLY</b>	<b>SPEC</b>
PU-806B	6115-01-471-1506	G17406	R62700	TA-13230E6852	MIL-P-53132/19
Technical Manual	Operator, Unit and Direct Support			TM 9-6115-663-13&P	
Physical Characteristics					
<b>Dimensions LWH (in) &amp; (Cube) (ft<sup>3</sup>)</b>		<b>Ship Cube (ft<sup>3</sup>)</b>		<b>Wet Weight (lbs)</b>	<b>Ship Weight (lbs)</b>
165 x 95 x 88 & (788)		788		6860	6500

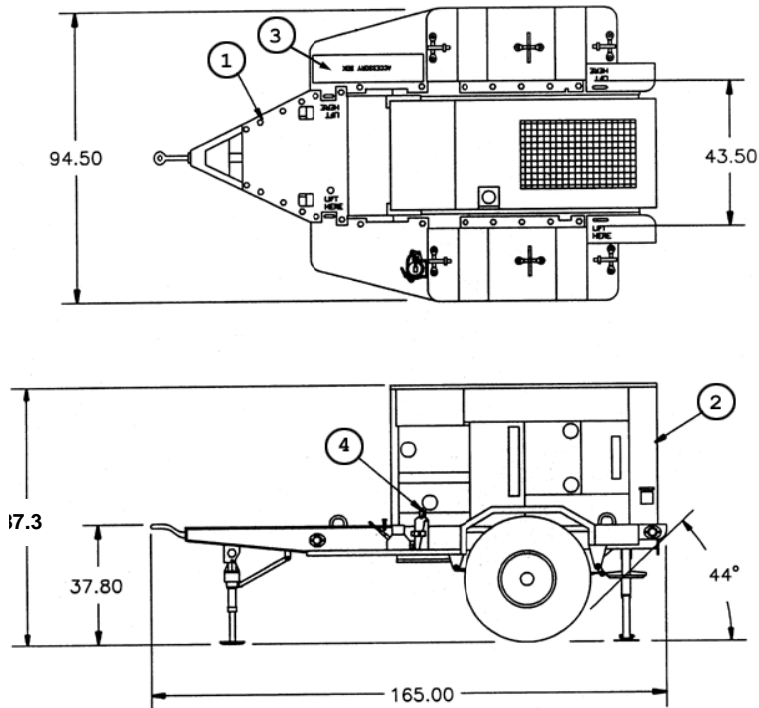

FIND	COMPONENT	QTY	IDENTIFIER
1	2-1/2 Ton modified trailer, M200A1	1	97403-13229E9632
2	TQ Generator set, DED, 60 kW, 400 Hz, MEP-816B	1	6115-01-462-0292
3	Accessory box	1	97403-13229E7946
4	Fire extinguisher, 5 lb., A-A-1106	1	4210-00-270-4512

Figure A-26 PU-806B

MIL-HDBK-633A

APPENDIX A

60 kW TQ Power Plant, 50/60 Hz, TRLMTD

Identification Data					
Description	60 kW TQ POWER PLANT, 50/60 Hz, TRLMTD			Camouflage: 97403-13228E1616	
<b>Model</b>	<b>NSN</b>	<b>LIN</b>	<b>SSN</b>	<b>ASSEMBLY</b>	<b>SPEC</b>
PP-AN/MJQ-41B	6115-01-474-3776	P42194	R62700	TA-13230E6854	MIL-P-53132/17
Technical Manual	Operator, Unit and Direct Support			TM 9-6115-663-13&P	
Physical Characteristics					
<b>Dimensions LWH (in) &amp; (Cube) (ft<sup>3</sup>)</b>	<b>Ship Cube (ft<sup>3</sup>)</b>		<b>Wet Weight (lbs)</b>		<b>Ship Weight (lbs)</b>
165 x 95 x 88 & (788) each	788 each		Unit A: 6880 Unit B: 6900		Unit A: 6440 Unit B: 6460

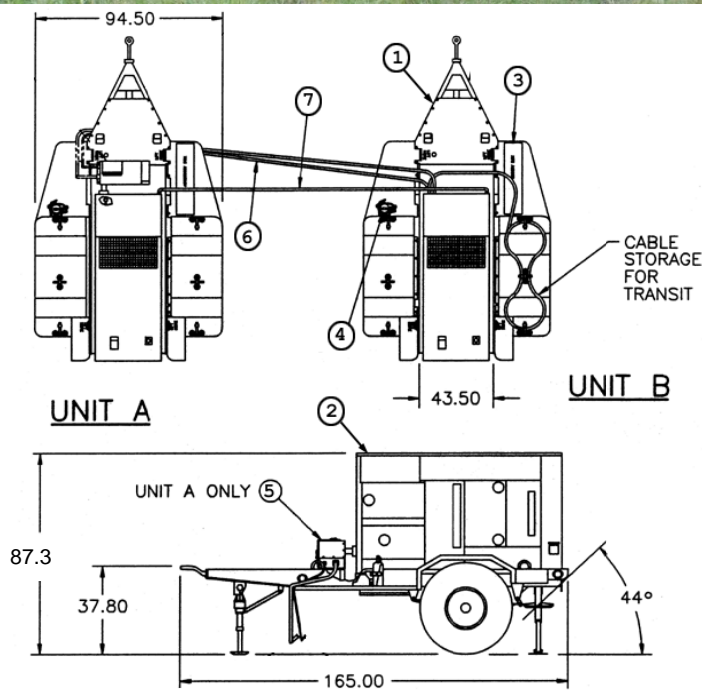

FIND	COMPONENT	QTY	IDENTIFIER
1	2-1/2 Ton modified trailer, M200A1	2	97403-13229E9632
2	TQ Generator set, DED, 60 kW, 400 Hz, MEP-806B	2	6115-01-462-0292
3	Accessory box	2	97403-13229E7946
4	Fire extinguisher, 5 lb., A-A-1106	2	4210-00-270-4512
5	Switch box (unit A)	1	97403-13229E5795-3
6	Cable assembly (unit B)	1	97403-13229E5741
7	Paralleling cable assembly	2	30554-88-22209

Figure A-27 PP-AN/MJQ-41B

MIL-HDBK-633A

APPENDIX A

PP-AN/MJQ-1612, TQ POWER PLANT, DED, 60kW, 50/60 Hz, TRLMTD AIR FORCE POWER PLANT  
NOT TYPE CLASSIFIED FOR ARMY USE

Identification Data					
Description	TQ POWER PLANT, DED, 60kW, 50/60Hz, TRLMTD AF			Camouflage: 97403-13228E1617	
<b>Model</b>	<b>NSN</b>	<b>LIN</b>	<b>SSN</b>	<b>ASSEMBLY</b>	<b>SPEC</b>
PP-AN/MJQ-1612	6115-01-349-1536		M510	TA-13229E9635	
Technical Manual					
Physical Characteristics					
<b>Dimensions LWH (in) &amp; (Cube) (ft<sup>3</sup>)</b>	<b>Ship Cube (ft<sup>3</sup>)</b>		<b>Wet Weight (lbs)</b>	<b>Ship Weight (lbs)</b>	
222.6 x 96.0 x 96.0 & (1187)	1172		14700	15800	

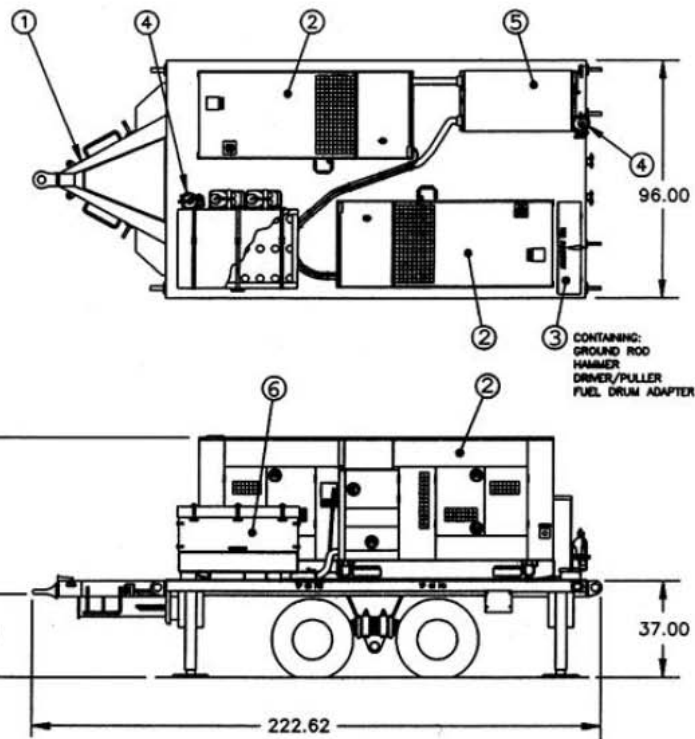

COMPONENT	QTY	FIND	IDENTIFIER
AF Trailer Generator Assembly, M1061A1	1	1	2330-01-573-0985
TQ Gen set, DED, 60 kW, 50/60 Hz, MEP-806B	2	2	6115-01-462-0291
Accessory box	1	3	97403-13229E7946
Fire extinguisher, 5 lb., A-A-1106	2	4	4210-00-270-4512
Switch box	1	5	97403-13230E4550
Cable storage box	1	6	97403-13230E4580

Figure A- 28 PP-AN/MJQ-1612

MIL-HDBK-633A

APPENDIX A

**PP-AN/MJQ-1632, TQ POWER PLANT, DED, 60kW, 400 Hz, TRLMTD AIR FORCE POWER PLANT -  
NOT TYPE CLASSIFIED FOR ARMY USE**

Identification Data					
Description	TQ POWER PLANT, DED, 60kW, 400 Hz, TRLMTD AF PP			Camouflage: 97403-13228E1617	
<b>Model</b>	<b>NSN</b>	<b>LIN</b>	<b>SSN</b>	<b>ASSEMBLY</b>	<b>SPEC</b>
PP-AN/MJQ-1632	6115-01-346-0157		M510	TA-13230E4595	
Technical Manual					
Physical Characteristics					
<b>Dimensions LWH (in) &amp; (Cube) (ft<sup>3</sup>)</b>	<b>Ship Cube (ft<sup>3</sup>)</b>		<b>Wet Weight (lbs)</b>	<b>Ship Weight (lbs)</b>	
222.6 x 96.0 x 96.0 & (1187)	1172		14700	15800	

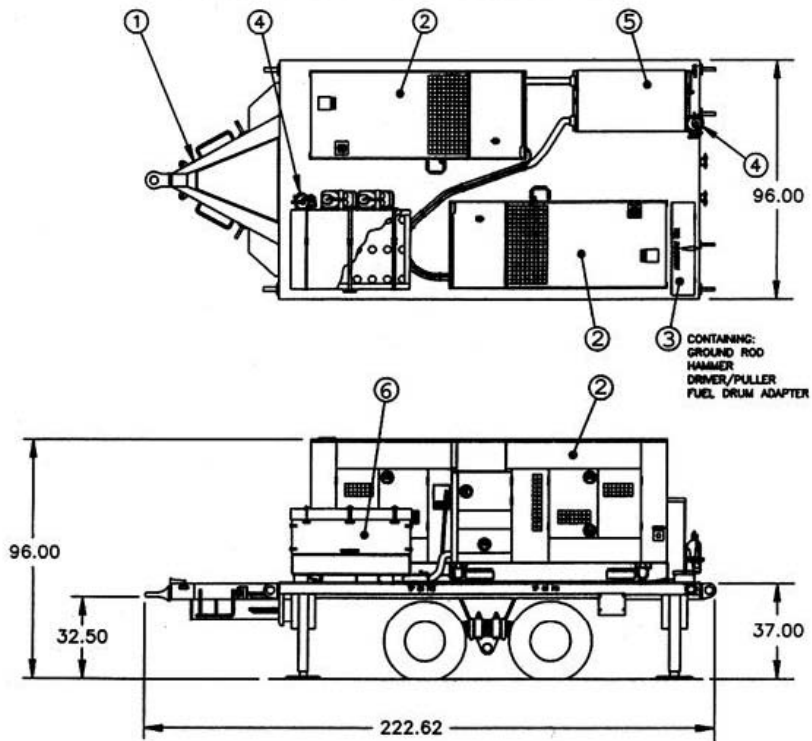

COMPONENT	QTY	FIND	IDENTIFIER
AF Trailer Generator Assembly, M1061A1	1	1	2330-01-573-0985
TQ Generator set, DED, 60 kW, 400 Hz, MEP-816B	2	2	6115-01-462-0292
Accessory box	1	3	97403-13229E7946
Fire extinguisher, 5 lb., A-A-1106	2	4	4210-00-270-4512
Switch box	1	5	97403-13230E4550
Cable storage box	1	6	97403-13230E4580

Figure A- 29 PP-AN/MJQ-1632

MIL-HDBK-633A  
APPENDIX A

This Page Intentionally Left Blank

## MIL-HDBK-633A

## APPENDIX A

## 100 kW Tactical Quiet Generator Set (TQG)

Identification Data			
Description	100 kW TQG, 50/60 Hz, DED, Skid Mtd		
Model	MEP-807A		
NSN	6115-01-296-1463		
LIN	G17596		
SSN	M54400		
Trailer Mounted Conf.	PU-807A, <a href="#">Figure A-31</a>		
Physical Characteristics			
Dimensions LWH (in)	106 x 40 x 65 (Cube: 160 ft <sup>3</sup> )		
Wet Weight (lbs)	6100		
Engine	Caterpillar – Model: 3126B 4 cyl Turbo Diesel, 282 hp @ 1800 RPM, 24 VDC starter, liquid cooled, electronic governor, EPA certified		
Instrumentation	Digital Display		
Fuels	Diesel DL-1, DL-2; Jet Fuel JP-8.		
Fuel Capacity	Fuel tank: 66 gallons		
Performance Characteristics			
Power Rating	60 Hz: 100 kW, 0.8 pf @ 4000 ft/95°F, 50 Hz: 83.3 kW, 0.8 pf @ 4000 ft/95°F		
Environmental Capability	-25°F to 120°F, rain, humidity, altitude, sand/ dust, transportation, cold storage: -60°F, salt spray, fungus, 15° incline.		
Protective Devices	Over-speed, High temp, Low oil pressure, Low fuel, Under-voltage, Over-voltage, Short circuit, Overload, Reverse power, Diagnostics		
Fuel Consumption.	7.8 gph @ rated load		
Human Factors	MIL-STD-1474.		
Noise	70/68 dBA @ 7 meters (23 ft).		
Reliability (MTBOMF)	1250 hr		
Maintenance Ratio	0.026 max		
Electrical Characteristics			
Connection	120/208V, 3ph, 4 wire	240/416V, 3ph, 4 wire	Freq adj range
Volt adj range (50 Hz)	190 – 213 V	380 – 426 V	48 - 52 Hz
Volt adj range (60 Hz)	197 - 240 V	395 - 480 V	58 - 62 Hz
Electrical	Drip proof generator enclosure, fungus & moisture treated, solid state voltage regulator, solderless connectors, Synchronous. brushless generator		
Electrical Performance			
Electric Power Quality	AC Voltage		Frequency
Regulation	3%		3%
Modulation	1%		
Short term steady st stability (30 sec)	2% bandwidth		2% bandwidth
Long term steady state stability (4 hr)	4% bandwidth		3% bandwidth
Application/rejection of rated load, recovery time	20% dip/30%rise, 3 sec		4% under/over, 4 sec
Motor load	40% dip, 5 sec to 95% init volt		
Max waveform deviation factor	5%		
Individual waveform harmonic	2%		
EMI	Meets MIL-STD-461		
EMP	HAEMP IAW MIL-STD-2169		
Optional Equipment			
Description	NSN	Weight (lbs)	Effect on Dimensions (in)
Winterization kit	TBD	TBD	None (internal)
Technical Manuals			
Description	ARMY	Air Force	Marine Corps
Operators	TM 9-6115-729-10	35 C2-3-519-1	TM07464C-10/1
Unit, DS, GS	TM 9-6115-729-24& P	35 C2-3-519-2	TM07464C-24/2
Engine Maintenance			
Engine Parts			
Lube order			
Warranty			



MIL-HDBK-633A  
APPENDIX A

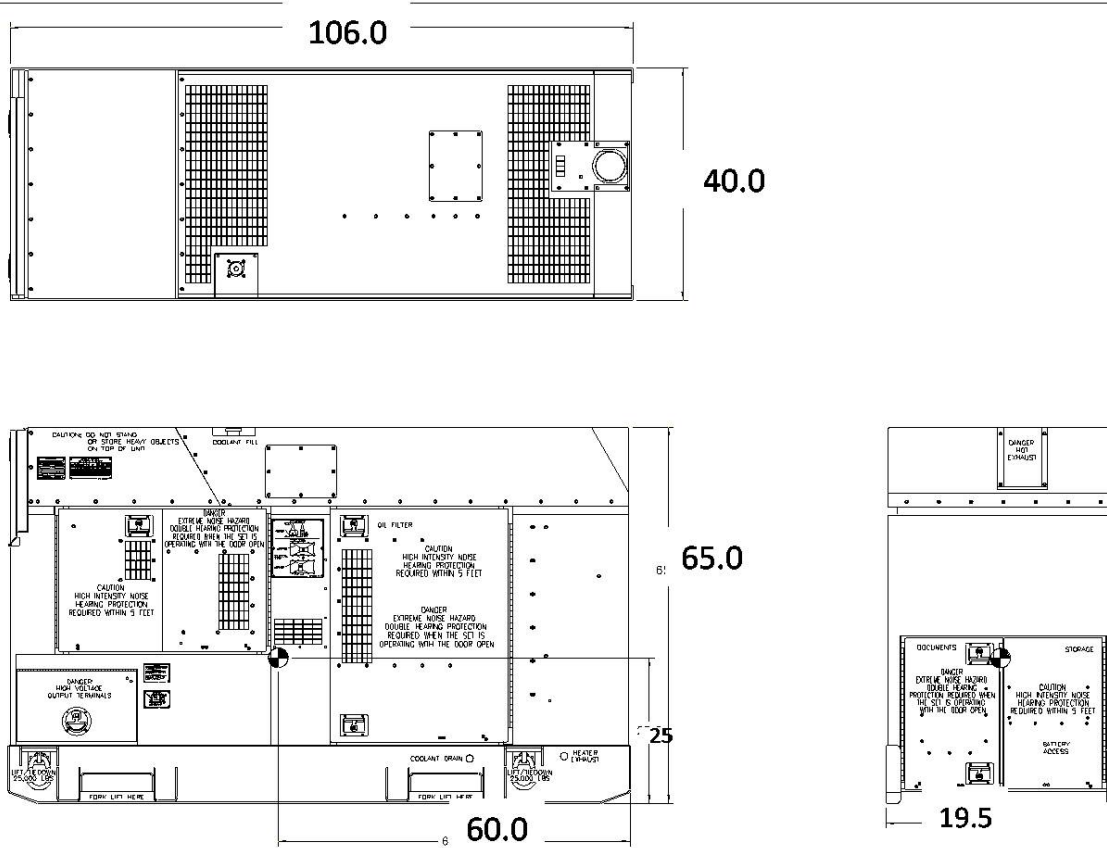

Figure A-30 100 kW Tactical Quiet Generator Set -

MIL-HDBK-633A

APPENDIX A

100 kW TQ Power Unit, 50/60 Hz, TRLMTD

Identification Data					
Description	100 kW TQ POWER UNIT, 50/60 Hz, TRLMTD			Camouflage: 97403-13228E1717	
<b>Model</b>	<b>NSN</b>	<b>LIN</b>	<b>SSN</b>	<b>ASSEMBLY</b>	<b>SPEC</b>
PU-807A	6115-01-471-7088	G1752B	M54400	TA-0116-1910	
Technical Manual	Operator, Unit and Direct Support				
Physical Characteristics					
<b>Dimensions LWH (in) &amp; (Cube) (ft<sup>3</sup>)</b>	<b>Ship Cube (ft<sup>3</sup>)</b>		<b>Wet Weight (lbs)</b>	<b>Ship Weight (lbs)</b>	
225 x 96 x 102 & (1275)	1275		11620	11620	

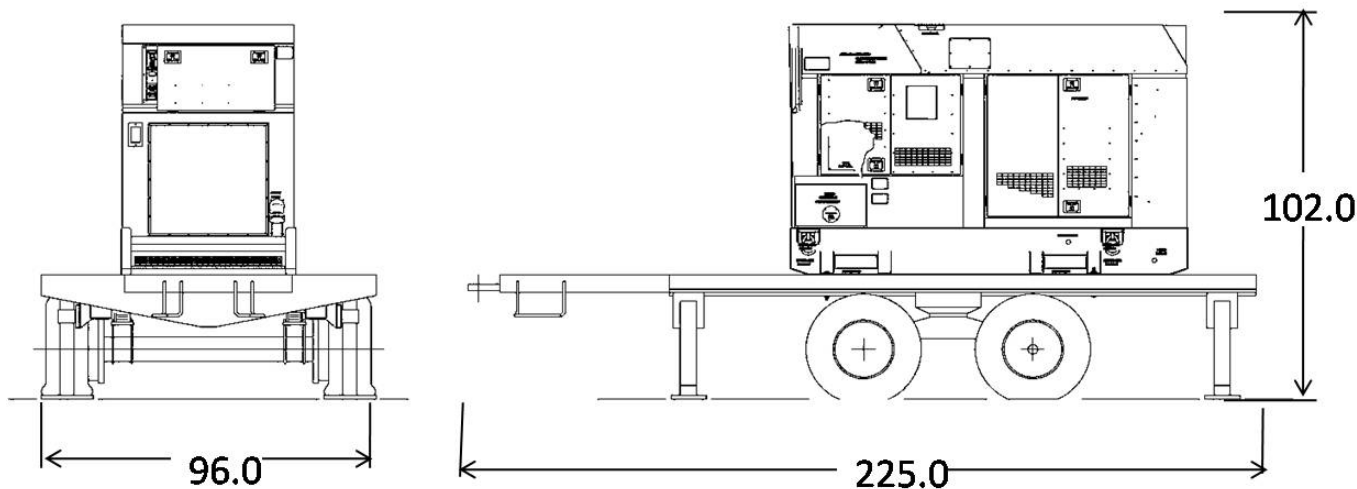

FIND	COMPONENT	QTY	IDENTIFIER
1	5 Ton modified trailer, M1061A1	1	97403-13230E4570
2	TQ Gen set, DED, 100 kW, 50/60 Hz, MEP-807A	1	6115-01-296-1463
3	Accessory box	1	97403-13229E7946
4	Fire extinguisher, 5 lb., A-A-1106	1	4210-00-270-4512

Figure A-31 PU-807A

MIL-HDBK-633A  
APPENDIX A

This Page Intentionally Left Blank

## MIL-HDBK-633A

## APPENDIX A

## 200 kW Tactical Quiet Generator Set

Identification Data			
Description	200 kW TQG, 50/60 Hz, DED, Skid Mtd		
Model	MEP-809A		
NSN	6115-01-296-1462		
LIN	G17664		
SSN	M54400		
Trailer Mounted Conf.	PU-809A, <a href="#">Figure A-33</a>		
Physical Characteristics			
Dimensions LWH (in)	114 x 50 x 75 (Cube: 250 ft <sup>3</sup> )		
Wet Weight (lbs)	9300		
Engine	Caterpillar – Model: C-12 4 cyl Turbo Diesel, 395 hp @ 1800 RPM, 24 VDC starter, liquid cooled, electronic governor, EPA certified		
Instrumentation	Digital Display		
Fuels	Diesel DL-1, DL-2; Jet Fuel JP-8.		
Fuel Capacity	Fuel tank: 128 gallons		
Performance Characteristics			
Power Rating	60 Hz: 200 kW, 0.8 pf @ 4000 ft/95°F, 50 Hz: 167 kW, 0.8 pf @ 4000 ft/95°F		
Environmental Capability	-25°F to 120°F, rain, humidity, altitude, sand/ dust, transportation, cold storage: -60°F, salt spray, fungus, 15° incline.		
Protective Devices	Over-speed, High temp, Low oil pressure, Low fuel, Under-voltage, Over-voltage, Short circuit, Overload, Reverse power, Diagnostics		
Fuel Consumption	13.9 gph @ rated load		
Human Factors	MIL-STD-1474.		
Noise	70/68 dBA @ 7 meters (23 ft).		
Reliability (MTBOMF)	600 hr minimum, 850 hr objective		
Maintenance Ratio	TBD		
Electrical Characteristics			
Connection	120/208V, 3ph, 4 wire	240/416V, 3ph, 4 wire	Frequency adj range
Volt adj range (50 Hz)	190 – 213 V	380 – 426 V	48 - 52 Hz
Volt adj range (60 Hz)	197 - 240 V	395 - 480 V	58 - 62 Hz
Electrical	Drip proof generator enclosure, fungus & moisture treated, solid state voltage regulator, solderless connectors, synchronous, brushless generator.		
Electrical Performance			
Electric Power Quality	AC Voltage		Frequency
	50/60 Hz		50/60 Hz
Regulation	3%		3%
Modulation	1%		
Short term steady state stability (30 sec)	2% bandwidth		2% bandwidth
Long term steady state stability (4 hr)	4% bandwidth		3% bandwidth
Application/rejection of rated load recovery time	30% dip/rise, 3 sec		4% under/over, 4 sec
Motor load	40% dip, 5 sec to 95% init volt		
Max waveform deviation factor	5%		
Individual waveform harmonic	2%		
EMI	Meets MIL-STD-461		
EMP	HAEMP IAW MIL-STD-2169		
Optional Equipment			
Description	NSN	Weight (lbs)	Effect on Dimensions (in)
Winterization kit	TBD	TBD	None (internal)
Technical Manuals			
Description	ARMY	Air Force	Marine Corps
Operators	TM9-6115-730-10	35C2-3-520-1	NONE
Unit, DS, GS	TM 9-6115-730-24& P	35C2-3-520-2	
Engine Maintenance			
Engine Parts			
Lube order			
Warranty			

MIL-HDBK-633A  
APPENDIX A

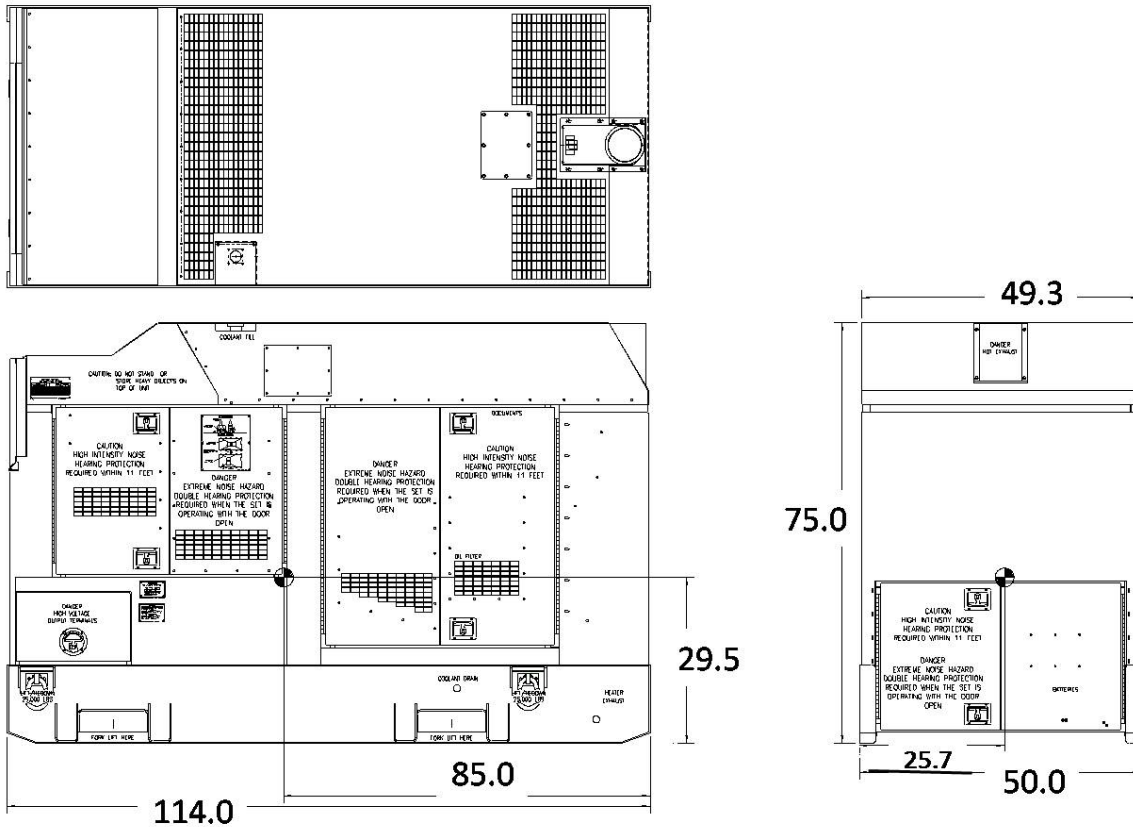

Figure A-32 200 kW Tactical Quiet Generator Set -

MIL-HDBK-633A

APPENDIX A

## 200 kW TQ Power Unit, 50/60 Hz, TRLMTD

Identification Data					
Description	200 kW TQ POWER UNIT, 50/60 Hz, TRLMTD			Camouflage: 97403-13228E1718	
<b>Model</b>	<b>NSN</b>	<b>LIN</b>	<b>SSN</b>	<b>ASSEMBLY</b>	<b>SPEC</b>
PU-809A	6115-01-471-7085	G26345	M54400	TA-0116-2910	
Technical Manual	Operator, Unit and Direct Support				
Physical Characteristics					
<b>Dimensions LWH (in) &amp; (Cube) (ft<sup>3</sup>)</b>		<b>Ship Cube (ft<sup>3</sup>)</b>		<b>Wet Weight (lbs)</b>	<b>Ship Weight (lbs)</b>
225 x 96 x 112 & (1400)		1400		14780	14780

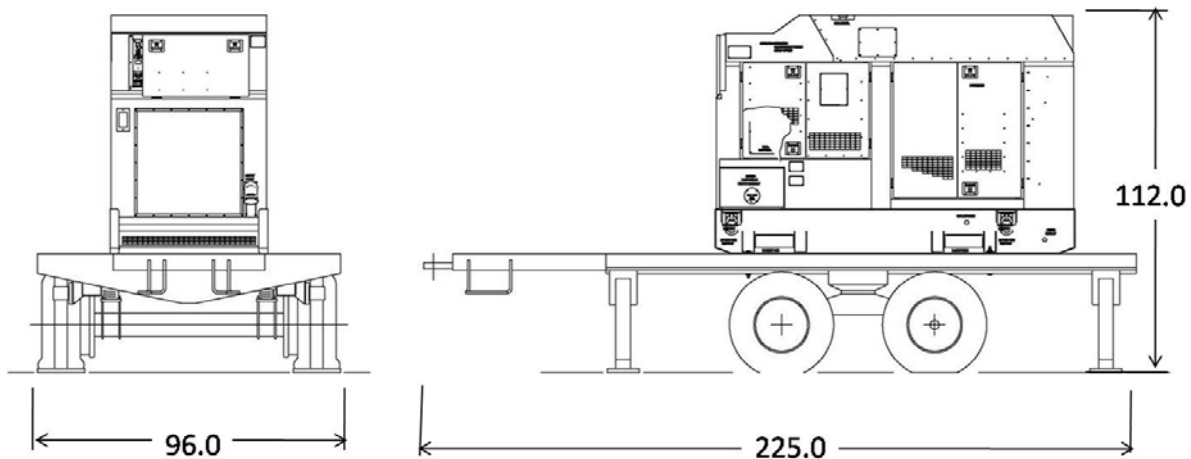

FIND	COMPONENT	QTY	IDENTIFIER
1	5 Ton modified trailer, M1061A1	1	97403-13230E4570
2	TQ Gen set, DED, 200 kW, 50/60 Hz, MEP-809A	1	6115-01-296-1462
3	Accessory box	1	97403-13229E7940
4	Fire extinguisher, 5 lb., A-A-1106	1	4210-00-270-4512

Figure A-33 PU-809A

MIL-HDBK-633A  
APPENDIX A

This Page Intentionally Left Blank

MIL-HDBK-633A  
APPENDIX A  
**840 kW Power Unit**

<b>Identification Data</b>			
Description	840 kW Power Unit, 50/60 Hz, DED		
Model	MEP-PU-810A (C-130 transport)	MEP-PU-810B (Highway transport)	
NSN	6115-01-486-4033	6115-01-486-4032	
LIN	Not Applicable: Air Force Unit	Z00221	
SSN			
Trailer mounted Configurations	Unit is wheel mounted <a href="#">Figure A-34</a>	Integral Highway trailer mounted <a href="#">Figure A-35</a>	
<b>Physical Characteristics</b>			
Dimensions LWH (in)	254 x 96 x 102 (Cube: 1440 ft <sup>3</sup> )	264 x 96 x 130 (Cube: 1902 ft <sup>3</sup> )	
Wet Weight (lbs)	25600 (Dry)	28580 (Dry)	
Engine	Diesel (2), 692 x 2 horsepower @ 1800 RPM, Model: Caterpillar 3456EPG, 24 VDC starter.		
Instrumentation	Voltmeter, frequency meter, ammeter, hour-meter, oil pressure, battery charging ammeter.		
Fuels	Diesel DL-1, DL-2; Jet Fuel JP-8.		
Fuel Capacity	Fuel tank: 120 gallons (day tank)		
<b>Performance Characteristics</b>			
Power Rating	840 kW (60 Hz), <span style="background-color: yellow;">???</span> kW (50 Hz), 0.8 pf lagging @ 4000 ft/125°F		
Environmental Capability	-25°F to 125°F for system. Rain, humidity, altitude, sand/dust, Air, road, rail transportable, vibration, cold storage, salt spray, fungus, 15° incline.		
Protective Devices	Automatic shut down with emergency bypass for low oil pressure, coolant high-temperature, and over-voltage, time over-current.		
Fuel Consumption	60 gph @ rated load.		
Human Factors	MIL-STD-1474.		
Noise	85 dBA @ 7 meters (23 ft).		
Reliability (MTBOMF)	Greater than 650 hrs		
Maintenance Ratio			
<b>Electrical Characteristics</b>			
Connection	Voltage adjustment range	Freq adj range	
2400/4160 V, 3 phase, 4 wire (60 Hz)	3720 – 4400 V	±3%	
2200/3800 V, 3 phase, 4 wire (50 Hz)	3400 – 4000 V	±3%	
Electrical Drip proof generator enclosure, fungus & moisture treated, solid state voltage regulator, solderless connectors, permanent magnet pilot excited, two Caterpillar SR4B 50/60 Hz generators.			
<b>Electrical Performance</b>			
Electric Power Quality	AC Voltage	Frequency	
Regulation	3%	3%	
Modulation	1%		
Short term steady st stability (30 sec)	2% bandwidth	1% bandwidth	
Long term steady state stability (4 hr)	2% bandwidth	2% bandwidth	
Application/rejection of rated load, recovery time	30% dip/rise, 2 sec	3% under/5% over, 4 sec/6 sec	
Motor load	N/A		
Max waveform deviation factor	5%		
Individual waveform harmonic	3%		
EMI	Meets MIL-STD-461		
EMP	HAEMP IAW MIL-STD-2169		
<b>Optional Equipment</b>			
Description	NSN	Weight (lbs)	Effect on Dimensions (in)
Winterization kit			None (internal)
<b>Technical Manuals</b>			
Description	ARMY	Air Force	Marine Corps
Deployment & Operation	TM 9-6115-484-14	TO 35C2-3-518-1	none
Parts Manual	TM 9-6115-484-24P	TO 35C2-3-518-4	



MIL-HDBK-633A  
APPENDIX A



PU-810A (C-130 Transportable)

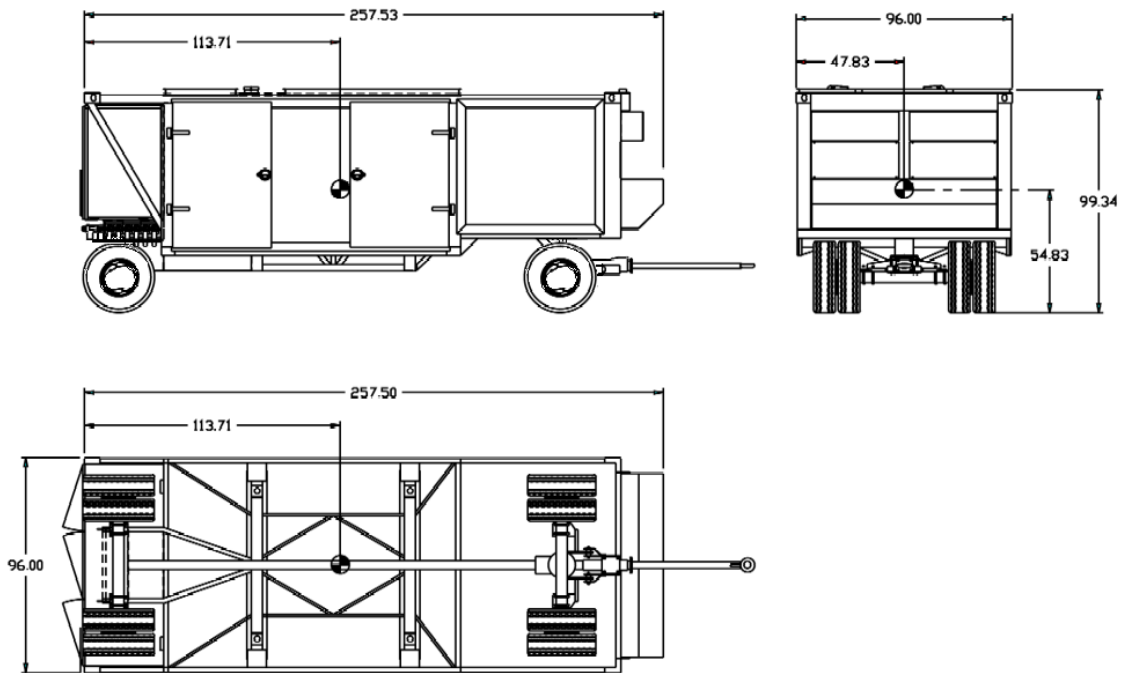

Figure A-34 PU-810A

MIL-HDBK-633A  
APPENDIX A

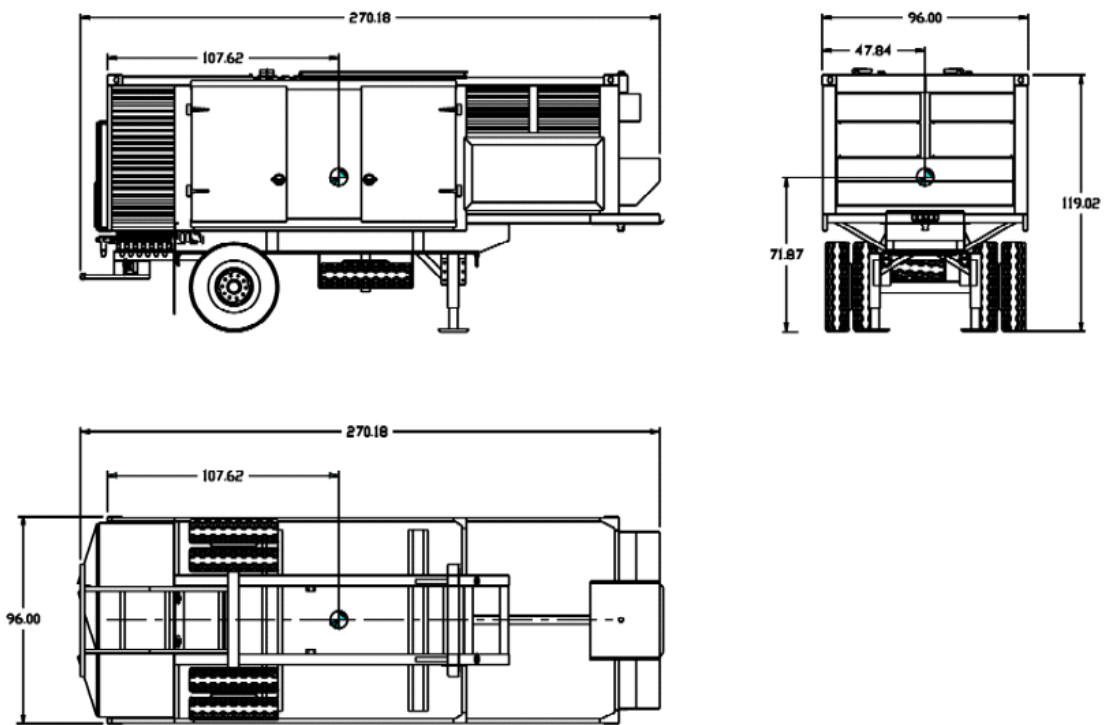

Figure A-35 PU-810B

**MIL-STD-633F**  
**APPENDIX B**  
**STANDARD FAMILY OF AUXILIARY POWER UNITS (APU)**

**B.1 SCOPE**

**B.1.1 Scope.** This Appendix identifies the current Auxiliary Power Unit (APU) members of the DoD Standard Family of MEPGS. Data contained in this Appendix is for information only and is provided to assist both field operation and materiel developer personnel to select the power generation source that will best meet their needs. The APUs are not separately fielded items but are part of a vehicle or shelter system. DoD activities are to utilize these power sources to the maximum extent practicable per DoD DIRECTIVE 4120.11.

**B.1.2 Appendix Organization.** This Appendix is a compilation of characteristics data sheets (see [Table B- I](#) Guide to CHARACTERISTICS DATA SHEETS of APPENDIX B) arranged by power rating capacity.

**Table B- I Guide to CHARACTERISTICS DATA SHEETS of APPENDIX B**

<b>MODEL NO.</b>	<b>ITEM DESCRIPTION</b>	<b>NSN</b>	<b>FIG</b>	<b>PAGE</b>
MEP-952	5 kW, 28 VDC, DED/APU	6115-01-317-2139	Figure B- 1	68
MEP-903A	10 kW, 60 Hz, DED/APU	6115-01-431-3062	Figure B- 2	70

**B.2 APPLICABLE DOCUMENTS**

**B.3 DEFINITIONS**

**B.3.1 Auxiliary Power Unit (APU).** An Auxiliary Power Unit (APU) is a power source consisting of a self-contained engine and generator, including remote controls, capable of producing electrical power when connected to its host's source of fuel and starting power.

**B.4 GENERAL DESCRIPTIONS**

**B.4.1 Item Descriptions.**

**B.4.1.1 5 kW 28 VDC Auxiliary Power Unit (APU).** The 5 kW 28 VDC APU is a newly developed diesel engine driven replacement for the 4.2 kW gasoline engine driven APU used on M577 Armored Personnel Carriers. The 4.2 kW APUs are noisy, unreliable, difficult to maintain and require an additional fuel (gasoline), not used by other equipment, to be brought to the battlefield. The new 5 kW 28 VDC APU eliminates these problems. More importantly, the 5 kW 28 VDC APU also provides power to the M1068 tracked vehicle, which houses the communications, intelligence and command and control computer suite, a lynch pin in the Army's Force XXI strategy. The APU utilizes a standard NATO slave receptacle to connect to a DC power system. The APU is usually started by the power provided via the NATO slave receptacle, but has a hand crank to start the set if batteries are not charged or available.

**B.4.1.2 10 kW, 60 Hz Auxiliary Power Unit (APU).** The 10 kW, 60 Hz, 120/240 volt APU was a joint development effort among the Army project managers; Project Manager, Mobile Electric Power (PM, MEP), PM, Joint Tactical Area Communication System (PM, JTACS), PM, Platforms (previously the PM, Standard Integrated Command Post System (PM, SICPS)), and PM, Air Defense Command and Control Systems (PM, ADCCS). The differing rail and tunnel dimensions between the SICPS shelter and the JTACS shelter cause the SICPS APU to be slightly modified (rail and muffler) for the JTACS application. Electrical generation hardware and performance of the JTACS APU are identical to the SICPS APU. The 10 kW APU has a remotely located control panel, usually mounted inside the shelter, which interfaces through the shelter utility tunnel.

**B.5 DETAILED DESCRIPTIONS**

**B.5.1 Detailed Descriptions.** Details of these Auxiliary Power Units are contained in the CHARACTERISTICS DATA SHEETS of [Figure B- 1](#) and [Figure B- 2](#)

MIL-HDBK-633A  
APPENDIX B

**5 kW, 28VDC, DED, Auxiliary Power Unit (APU)**

(Army Unique - Not Separately Type Classified)

<b>Identification data</b>	
Nomenclature	APU, 5 kW, DED, 28VDC
APU	MEP-952A
NSN	6115-01-317-2139
LIN	
SSN	
Used with M557 Armored Personnel Carrier and the M1068 Tracked carriers.	
<b>Physical Characteristics</b>	
Dimensions LWH (in)	34.5 x 30.5 x 17.0 (housed APU for external mounting) (Cube: 11.4 ft <sup>3</sup> )
Wet Weight (lbs)	550 (includes housing)
Engine	Farymann - Diesel, 13.2 hp @ 3000 rpm, Air cooled, Electronic governor, Starter: 28 VDC (from NATO slave receptacle) and hand crank (provided). No belts or pulleys.
Fuels	Diesel DL-1, DL-2 and jet fuel JP-8 and Jet A-1. Provided with quick disconnect fuel line.
Instrumentation	Start/prime & run/off switch, emergency stop, volt/current meter (with switch). Local and remote switch for remote operation. Indicators for power on, high eng temp, low oil, preheat on. Lamp test.
<b>Performance Characteristics</b>	
Electric Power Rating	5 kW (180 amps, 28 VDC), from -25°F to 4000 ft/95°F, derate 17% @ 8000 ft/95°F.
Environmental Capability	-25°F to 120°F, rain, humidity, sand/dust, cold storage -65°F, salt spray, fungus. Operable at inclines up to 27°.
Protective Devices	Automatic shut down with emergency bypass for low oil pressure, engine overtemp.
Fuel Consumption	0.42 gal/hour.
Noise	70 dBA @ 7 meters (23 ft).
Human Factors	MIL-STD-1474.
<b>Electrical Characteristics</b>	
Voltage Connection:	28VDC, NATO slave receptacle.
Electrical	Uses a Bradley M2/M3, Alternator. Brushless, solid state rectifier, solid state regulator. Capable of 280 amps @ 3000 rpm.
EMI	Suppressed to MIL-STD-461 limits.
EMP	Protected.
<b>Electrical Performance</b>	
Electric Power Quality	DC Voltage
Regulation	4%
Short term steady state stability (30 sec)	2% bandwidth
Long term steady state stability (4 hr)	2% bandwidth
Application/Rejection of rated load, recovery time	30% dip/rise, 1 sec
Rejection of rated load (transient), recovery time	40% dip/rise, 0.5 sec
DC ripple	5.5%
Voltage adjustment range	23 - 35 V
<b>Optional Equipment</b>	
None	
<b>Technical Manuals</b>	
OPERATORS, UNIT, DS, and GS :	ARMY: TM 9-6115-664-14

MIL-HDBK-633A  
APPENDIX B

5 kW, 28VDC, DED, Auxiliary Power Unit (APU)  
Photos of Prototype

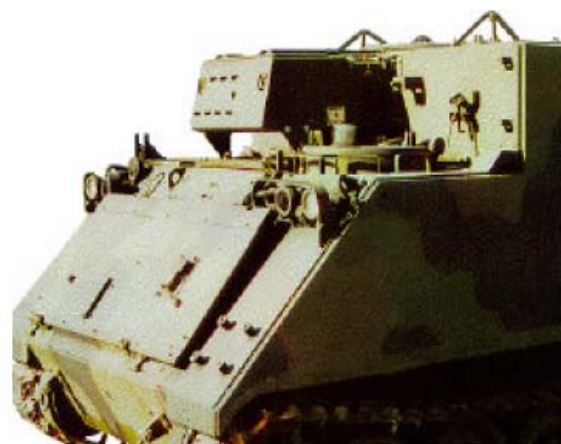

MEP-952A on M557  
(Power connector side)

MEP-952A on M557

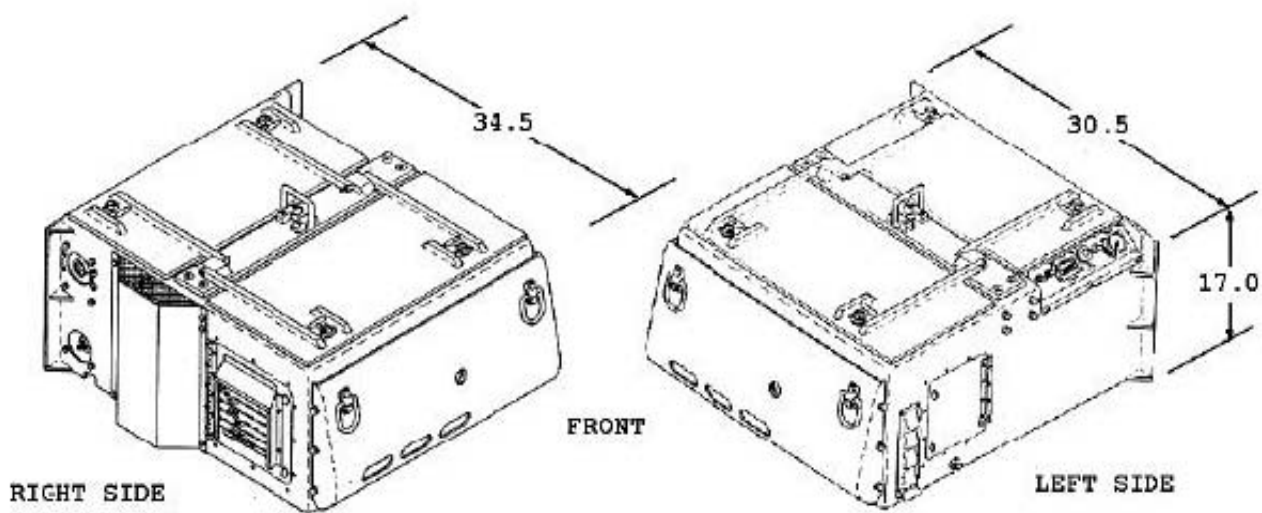

Figure B- 1 5 kW, 28VDC, DED, Auxiliary Power Unit

MIL-HDBK-633A  
APPENDIX B

**10 kW, 60 Hz, DED, Auxiliary Power Unit (APU)**

(Not Separately Type Classified)

<b>Identification Data</b>		
Nomenclature	APU, 10 kW, DED, 60 Hz	
APU	MEP-903A	
NSN	6115-01-431-3062	
LIN		
SSN		
Configuration	Used with SICPS shelter.	
<b>Physical Characteristics</b>		
Dimensions LWH (in)	36 x 26.5 x 27.7 (Cube:15.3 ft <sup>3</sup> )	
Weight (lbs)	Wet: 460 lb on rail for shelter tunnel insertion	
Engine	Kubota turbocharged diesel, 22.8 hp @ 3600 rpm, liquid cooled, Electronic governor, Starter: 28 VDC (from vehicle). No belts or pulleys. 20 amp battery charger.	
Fuels	Diesel DL-1, DL-2 and jet fuel JP-8 and Jet A-1. Uses vehicle fuel via quick disconnect fuel line.	
Instrumentation	Start/stop/preheat switch, volt meter, frequency meter, battery charging ammeter, percent load. Indicator for power on and malfunction indicator energizes appropriate fault lamp.	
<b>Performance Characteristics</b>		
Electric Power Rating	10 kW, 60 Hz @ .8 pf from -25°F to 120°F, 4000 ft/95 °F. Derate 3.5% per 1000 ft above 4000 ft up to 8000 ft.	
Environmental Capability	(when housed in shelter tunnel) -25°F to 120°F, rain, humidity, sand/dust, -60°F cold storage, salt spray, fungus.	
Protective Devices	Automatic shut down with emergency bypass for overspeed, low oil pressure, low fuel (day tank), high coolant temperature, overvoltage, undervoltage, short circuit, overload, AC interrupt, battle short.	
Fuel Consumption	0.?? gal/hour.	
Noise	70 dBA @ 7 meters (23 ft).	
RAM (MTBOMF)	400 hr.	
Human Factors	MIL-STD-1474.	
<b>Electrical Characteristics</b>		
Voltage Connection	120V, 1 phase, 2 wire	120/240V, 1 phase, 3 wire
Voltage Adj. Range	114 - 126	228 - 252
Frequency Adj. Range	+3%	+3%
Electrical	Alternator: brushless, solid state regulator, 2 pole, 3600 rpm, sealed bearings. Shelter has standard power outlets.	
EMI	Suppressed to MIL-STD-461 limits	
EMP	HAEMP protected	
<b>Electrical Performance</b>		
Electric Power Quality	Voltage	Frequency
Regulation (max)	3%	3%
Modulation (max)	3%	
Short term steady state stability (30 sec)	2% bandwidth	2% bandwidth
Long term steady state stability (8 hr)	4% bandwidth	3% bandwidth
Application, rejection of rated load (transient), recovery time	20% dip, 30% rise, 1 sec	3% under/over , 3 sec
Motor load (low power factor), recovery time	40% dip ,5 sec	
Max waveform deviation factor	6%	
Individual waveform harmonic	2%	
<b>Optional Equipment</b>		
None		
<b>Technical Manuals</b>		
OPERATORS, UNIT, DS, and GS	ARMY: TM 9-6115-670-14&P	

MIL-HDBK-633A  
APPENDIX B



10 kW APU and control panel  
removed from shelter. –  
rear view --



10 kW APU ready to slide  
into shelter.  
- front view -

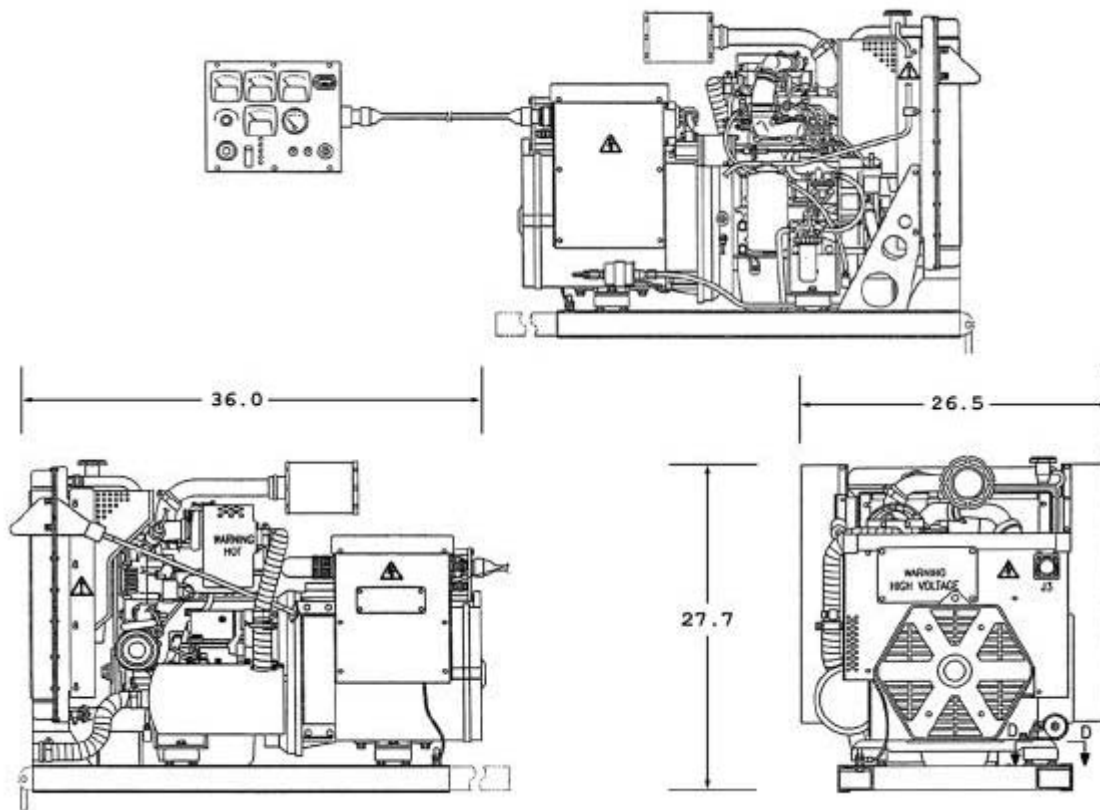

Figure B- 2 MEP-903A

MIL-HDBK-633A  
APPENDIX B

This Page Intentionally Left Blank



**MIL-HDBK-633A  
APPENDIX C**

**STANDARD FAMILY OF AVIATION GROUND POWER UNITS**

**C.1 SCOPE**

C.1.1 Scope. This Appendix identifies the current members of the DoD Standard Family of MEPGS for aviation ground power support. Data contained in this Appendix is for information only and is provided to assist both field operation and materiel developer personnel to select the power generation source that will best meet their needs. DoD activities are to utilize these power sources to the maximum extent practicable per DoD DIRECTIVE 4120.11.

C.1.2 Appendix Organization. This appendix is a compilation of characteristics data sheets (see [Table C- I](#) Guide to CHARACTERISTICS DATA SHEETS of APPENDIX C) arranged by power rating capacity.

**Table C- I Guide to CHARACTERISTICS DATA SHEETS of APPENDIX C**

MODEL NO.	ITEM DESCRIPTION	NSN	FIG	PAGE
MEP-362A	10 kW, 28VDC, GTED, Aircraft Support Unit, Integral wheel mount	6115-01-161-3992	Figure C- 1	74
MEP-356A	60 kW, 400 Hz; 2 kW, 28VDC; Pneumatic, Self Propelled, GTED, Aviation Ground Power Unit	6115-00-420-8486	Figure C- 2	76
MEP-357A	72 kW, 400 Hz; 21 kW, 28VDC; Self Propelled, DED, Aviation Support Unit	6115-00-110-1859	Figure C- 3	78

**C.2 APPLICABLE DOCUMENTS**

This section is not applicable to this Appendix.

**C.3 DEFINITIONS**

C.3.1 Use definitions of basic document.

**C.4 GENERAL DESCRIPTIONS**

C.4.1 Item Descriptions.

C.4.1.1 10 kW 28 VDC Start Cart (MEP-362A). The 28 VDC start cart is a wheeled aviation ground support generator set used to start and service aircraft (primarily helicopters) utilizing 28 volt direct current. The start cart is gas turbine engine powered. Power is provided via a standard 28 VDC aircraft connection.

C.4.1.2 60 kW, 400 Hz, and pneumatic Aircraft Ground Support Unit. This self propelled unit provides electrical and pneumatic (bleed air) power to start and service aircraft by the USAF. The unit is gas turbine engine powered.

C.4.1.3 72 kW, 400 Hz; 21 kW 28 VDC Aircraft Ground Support Power Unit. This unit is an integral trailer mount, AC & DC power unit to start and service aircraft by the Navy. The unit is diesel engine driven. The unit has AC & DC power cable retracting reels and a parking brake.

C.4.2 Delivered condition.

C.4.2.1 Safety Items. The items of this Appendix are delivered with fire extinguishers. Aircraft ground support generators and the connected aircraft should have a single common ground.

C.4.3 NATO slave receptacle. A NATO slave receptacle can be used to start the generator set from an external 24 VDC power source.

**C.5 DETAILED DESCRIPTIONS**

C.5.1 Detailed Descriptions. Detailed descriptions are contained in the CHARACTERISTICS DATA SHEETS of [Figure C- 1](#) through [Figure C- 3](#).

MIL-HDBK-633A  
APPENDIX C**10 kW, 28 VDC, GTE, Aircraft Support Unit**

<b>Identification Data</b>			
Nomenclature	GEN SET, 10kW, GTE, 28VDC		
Model Number	MEP-362A		
NSN	6115-01-161-3992		
LIN	G38140		
SSN			
<b>Physical Characteristics</b>			
Dimensions LWH (in)	89.0 x 71.0 x 49.0 (Cube: 179 ft <sup>3</sup> )		
Weight (lbs)	Dry: 960		Wet: 1175
Mobility	All weather frame and housing, wheel mounted, parking brake. A 40 foot power cable is provided.		
Engine	Gas Turbine, 50300 rpm (12000 at gearbox), Tiernay Turbines Model:101800-1, 28 VDC starter.		
Fuels	JP-8, Jet-A. Fuel tank: 32 gallons,.		
Instrumentation	On/off switch, hourmeter, voltmeter, output current meter, battery charging meter.		
<b>Performance Characteristics</b>			
Electric Power Rating	10 kW @ 125°F/MSL, 107°F/5000 ft, 95°F/8000 ft.		
Environmental Capability	-65°F to 125°F, rain, humidity, altitude, sand/dust, transportation, cold storage - 65°F, salt spray, fungus.		
Protective Devices	Automatic shut down with emergency bypass for low fuel, low oil pressure, engine overtemp, overspeed, overload, overvoltage, generator overtemp and undervoltage		
Fuel Consumption	8 gal/hour		
Noise	Not specified.		
Human Factors	MIL-STD-1474.		
<b>Electrical Characteristics</b>			
Voltage Connection:	28VDC, 2 wire with ground		
Electrical	Drip proof generator enclosure, fungus & moisture treated, solid state voltage regulator, generator: Teledyne Brown, model 481-007.		
EMI	Suppressed to MIL-STD-461 limits.		
EMP	HEAMP protected.		
<b>Electrical Performance</b>			
<b>Electric Power Quality</b>		<b>DC Voltage</b>	
Regulation	4%		
Short term steady state stability (30 sec)	2% bandwidth		
Long term steady state stability (4 hr)	2% bandwidth		
Application of rated load (transient) recovery	30% dip 1 sec		
Rejection of rated load (transient) recovery	40% rise 0.5 sec		
DC ripple	5.5%		
<b>Optional Equipment</b>			
<b>None</b>			
<b>Technical Manuals</b>			
<b>Army</b>	<b>Air Force</b>	<b>Marine Corps</b>	<b>Navy</b>
TM 5-6115-612-12			AG-320B0-OMM-000
TM 5-6115-612-34			AG-320B0-MME-000
TM 5-6115-612-24P	TO 35C2-3-471-4	TM 6115-24P/1	AG-320B0-IPE-000

MIL-HDBK-633A  
APPENDIX C

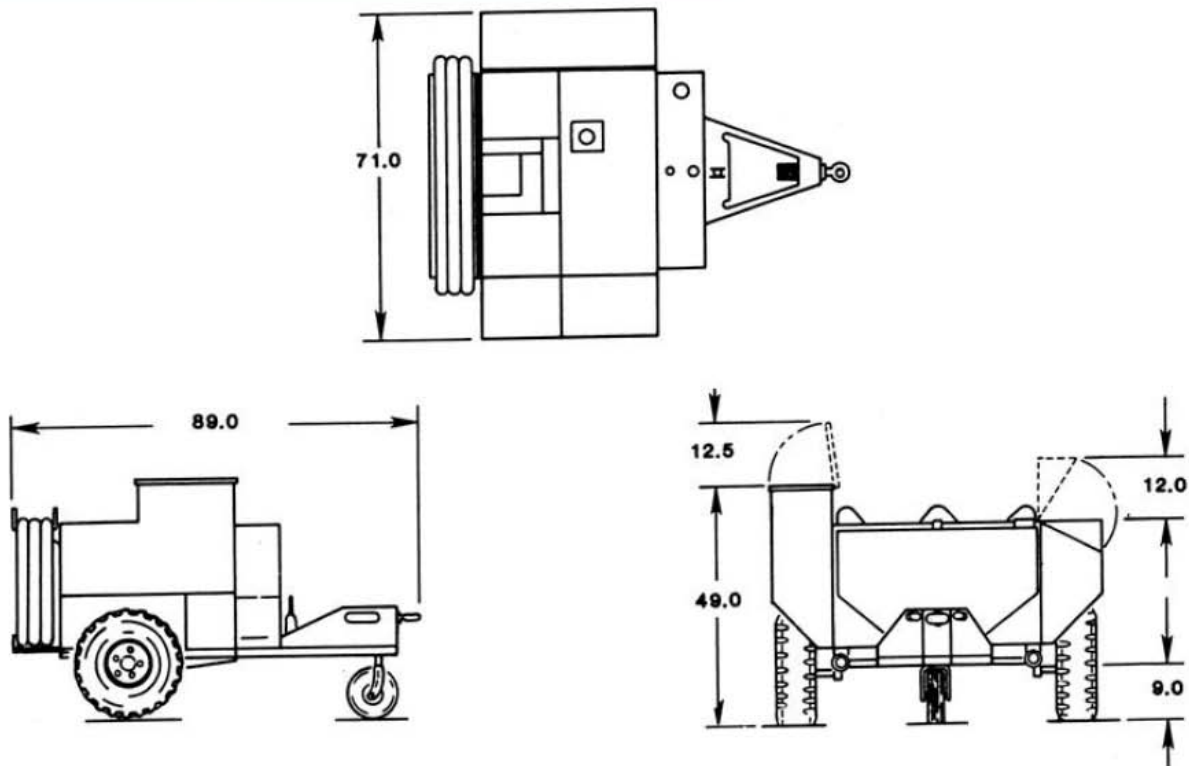
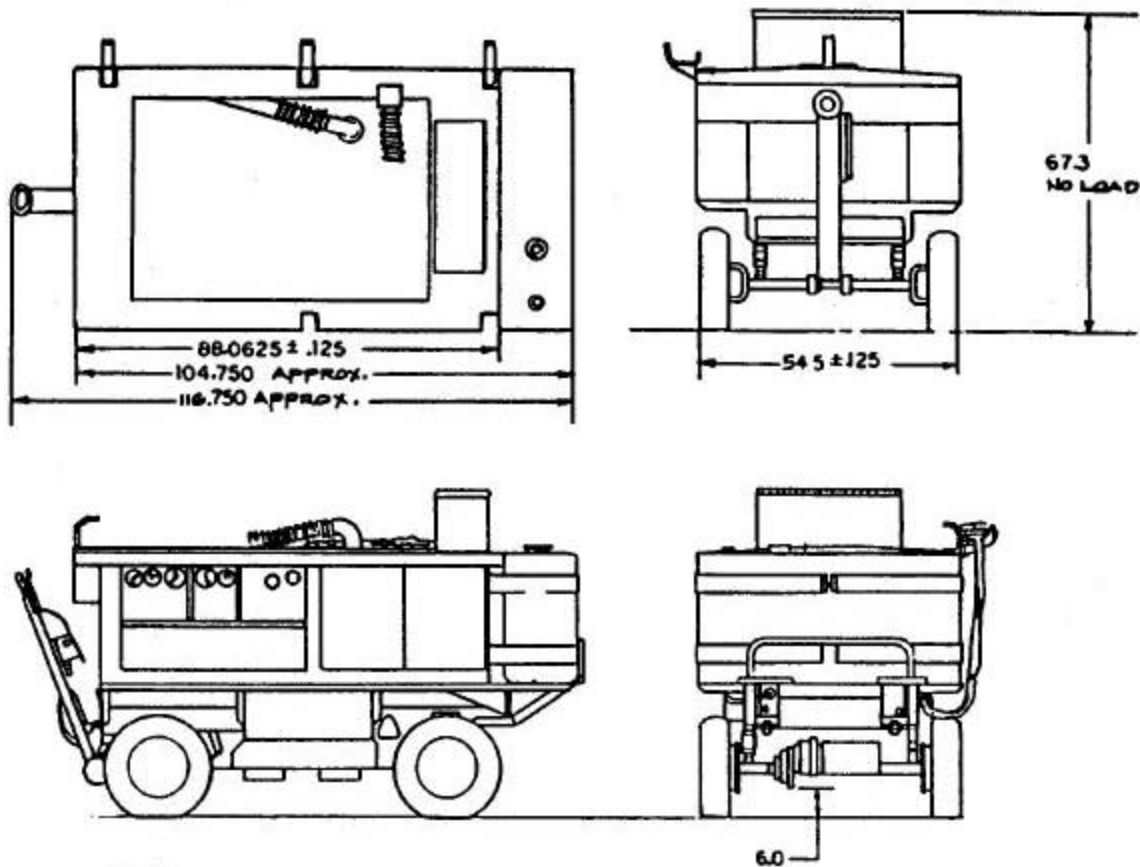

Figure C-1 MEP-362A

MIL-HDBK-633A  
APPENDIX C**60kW Aircraft Ground Support Unit**  
(Air Force Unit, Not Type Classified for Army use)

<b>Identification Data</b>			
Nomenclature	Gen Set, 60kW, GTE, 400 Hz, pneumatic, self propelled		
Model Number	MEP-356A		
NSN	6115-00-420-8486		
LIN			
SSN			
<b>Physical Characteristics</b>			
Weight (lbs)	Dry: 2800	Wet: 3940	
Dimensions LWH (in)	116.75 x 54.5 x 67.3 (Cube: 247 ft <sup>3</sup> )		
Engine	Gas turbine, 177 horsepower @ 42,000 rpm, bleed air, 24 VDC starter.		
Fuel	JP-8, Jet-A. Fuel tank: 190 gallons.		
Mobility	Fully enclosed, electrically self propelled, wheel mounted, AC power cable, pneumatic hose, parking brake.		
Instrumentation	Hour meter, AC/DC voltmeter, frequency meter, battery charging ammeter & voltmeter, fuel level, tachometer.		
Pneumatic	Flow rate: 150 – 4 pounds/minute. Pressure: 51 – 2 psia @ 385°F		
<b>Performance Characteristics</b>			
Electric Power Rating	60 kW, 0.8 power factor @ 5000 ft/125°F		
Environmental Capability	-65°F to 125°F, rain, humidity, altitude, sand/dust, transportation, -65°F cold storage, salt spray, fungus.		
Protective Devices	Short circuit, AC overvoltage/undervoltage, AC under-frequency, low oil pressure, high temperature, overspeed.		
Fuel Consumption	33 gal/hr (41 w/ bleed air).		
Reliability (MTBF)	478 Hr. specified.		
Noise	93 dBA @ 25 feet.		
Human Factors	MIL-STD-1474.		
<b>Electrical Characteristics</b>			
Voltage Connection:	3 phase: 115/200 V - 4 wire, 60 foot cable: 400 Hz convenience outlet, DC: 28 V - 2 wire (propulsion and utility only, not for aircraft), 28 VDC slave receptacle.		
Electrical	Drip proof generator enclosure, fungus & moisture treated, solid state voltage regulator, solderless connectors, Separate AC brushless rotary exciters: ? pole (AC), x pole (DC).		
EMI	Suppressed to MIL-STD-461 limits.		
EMP	not protected.		
<b>Electrical Performance</b>			
Electric Power Quality			
Condition	Voltage	Frequency	
Short term steady state stability	not rated	0.5 % bandwidth	
Long term steady state stability	not rated	not rated	
Application of rated load (transient) , recovery	25% dip, 0.25 sec	1% undershoot, 0.4 sec	
Rejection of rated load (transient), recovery time	25% rise, 0.25 sec	0.25% overshoot, 1.5 sec	
Max waveform deviation factor	not rated		
Individual waveform harmonic	2%		
Motor load	not rated		
Mobility	Wheel mounted, electric self-propelled		
<b>Optional Equipment</b>			
None			
<b>Technical Manuals</b>			
<b>Air Force</b>	TO 35C2-3-372-11	TO 35C2-3-13	TO 35C2-3-14

MIL-HDBK-633A  
APPENDIX C



NOTE:  
DIMENSIONS ARE IN INCHES.

Figure C- 2 MEP-356A

MIL-HDBK-633A  
APPENDIX C**Aircraft Ground Support Power Unit**  
(Navy Unit, Not Type Classified for Army use)

<b>Identification Data</b>			
Nomenclature	Gen Set, 72 kW, DED, 400 Hz; 21 kW, 28 VDC		
Model Number	MEP-357A		
NSN	6115-00-110-1859		
LIN			
SSN			
<b>Physical characteristics</b>			
Weight (lbs)	Dry: 7000	Wet: 7200	
Dimensions LWH(in)	116.75 x 60.0 x 44.0 (Cube: 178 ft <sup>3</sup> )		
Mobility	Fully enclosed integral trailer mount, AC & DC power cable with retracting reels; parking brake; running lights.		
Engine	Diesel, 215 horsepower @ 1846 rpm, Detroit Diesel Co., 24 VDC starter.		
Fuels	DL-1, DL-2, marine diesel. Emergency: JP-5, JP-8. Fuel tank: 30 gallons.		
Instrumentation	On/off switch, hour, AC/DC volt, frequency, AC/DC ammeter, hourmeter, oil pressure, coolant temperature, fuel level, tachometer.		
<b>Performance Characteristics</b>			
Power Rating	72 kW, 400 Hz, @ 0.8 power factor and 21 kW 28VDC @ MSL/125 °F.		
Environmental Capability	-25°F to 125°F, rain, humidity, altitude, sand/dust, transportation, cold storage: -45°F, salt spray, fungus.		
Fuel Consumption.	6.7 gal/hours at rated load		
Protective Devices	Low fuel, high coolant temperature, DC overvoltage, AC overvoltage/undervoltage overfrequency/underfrequency, engine overspeed low oil pressure. Fault indicators for above. Thermal and magnetic overload protection.		
Noise	87 dBA @ 25 feet.		
Human Factors	MIL-STD-1474.		
Reliability (MTBOMF)	250 hr. (specified)		
<b>Electrical Characteristics</b>			
Voltage Connection:	400 Hz, 3 phase: 115/200 V - 4 wire, DC: 28 V - 2 wire.		
<b>Adjustment Range</b>	<b>Voltage</b>	<b>Frequency</b>	
115/200 V, 3 ph, 4 wire	105-125 V	380-440 Hz	
28 VDC	23-35 V		
Electrical	Drip proof generator enclosure, fungus & moisture treated, solid state voltage regulator, solderless connectors, static exciter generator 24 VDC power supply with 750 and 1000 amp current limits. Marathon/Lima brushless generator.		
EMI	Suppressed to MIL-STD-461 limits.		
EMP	Not protected.		
<b>Electrical Performance</b>			
<b>Electric Power Quality</b>	<b>AC Voltage</b>	<b>DC Voltage</b>	<b>Frequency</b>
Regulation (max)	1%	0.5 VDC	1%
Modulation (max)	1%		
Short term steady state stability (30 sec)	1%	2%	0.5%
Long term steady state stability (4 hr)	1%	2%	1%
Application/rejection of rated load, recovery time	25% dip/rise, 0.4 sec	13% dip/rise, 0.5 sec	nr , 1 sec
Motor load	nr		
Max waveform deviation factor	nr		
Individual waveform harmonic	2%		
DC ripple voltage		1.5 volts	
<b>Optional Equipment</b>			
Winterization system:			
<b>Technical Manuals</b>			
Navy	OPERATORS:	NAVAIR 19-45-20	

MIL-HDBK-633A  
APPENDIX C

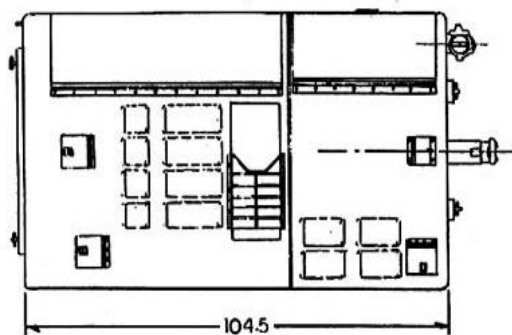

TOP VIEW

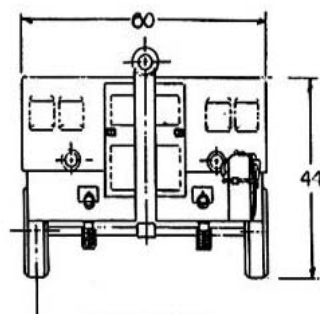

FRONT VIEW

NOTE: ALL DIMENSIONS ARE IN INCHES.

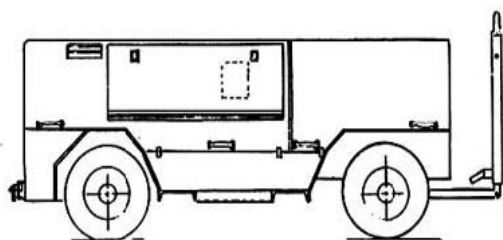

SIDE VIEW-RH

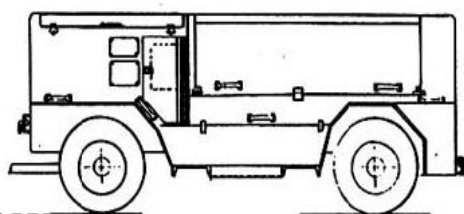

SIDE VIEW-LH

MEP-357A

Figure C-3 MEP-357A

MIL-HDBK-633A  
APPENDIX C

This Page Intentionally Left Blank



MIL-HDBK-633A  
**APPENDIX D**  
 POWER DISTRIBUTION AND ILLUMINATION SYSTEM, ELECTRICAL (PDISE)

D.1. SCOPE

D.1.1. Scope. This Appendix provides information on the Power Distribution and Illumination System, Electrical (PDISE) and the original Distribution and Illumination System, Electrical (DISE) which was developed for the Deployable Medical System (DEPMEDS).

D.1.2. Appendix Organization. This Appendix is a compilation of characteristics data sheets (see [Table D- I](#)) arranged by number of phases, current rating per phase and finally lights and receptacles.

**Table D- I. Guide to CHARACTERISTICS DATA SHEETS of APPENDIX D**

MODEL NO.	ITEM DESCRIPTION	NSN	FIG	PAGE
M200	200 amp/phase Feeder Sys - 3 Phase-DEPMEDS	6150-01-208-9755	Figure D- 2	84
M200 A/P	200 amp/phase Feeder Sys - 3 Phase	6150-01-308-5672	Figure D- 2	84
M100	100 amp/phase Feeder Sys - 3 Phase- DEPMEDS	6150-01-208-9754	Figure D- 3	85
M100 A/P	100 amp/phase Feeder Sys - 3 Phase	6150-01-308-5671	Figure D- 3	85
M40	40 amp/phase Dist Sys - 3 Phase-DEPMEDS	6150-01-208-9753	Figure D- 4	86
M40 A/P	40 amp/phase Dist Sys - 3 Phase	6150-01-307-9446	Figure D- 4	86
M60	60 amp Dist Sys - 1 Phase	6150-01-307-9445	Figure D- 5	87
M60 A/P	60 amp Dist Sys - 1 Phase-DEPMEDS	6150-01-208-9752	Figure D- 5	87
M46	Electrical Kit, Utility Receptacle	6150-01-208-9751	Figure D- 6	88

D.2. APPLICABLE DOCUMENTS

This section is not applicable to this Appendix.

D.3. DEFINITIONS Acronyms used in this Appendix:

- a. DISE - Distribution and Illumination System, Electrical: see D.4.1.1 below.
- b. PDISE - Power Distribution and Illumination System, Electrical: see D.4.1.1 below.
- c. DEPMEDS - Deployable Medical System - A mobile hospital system.
- d. GF - Used in this Appendix to indicate circuit breaker is a ground fault protection type.

D.4. GENERAL DESCRIPTIONS

D.4.1. Item Descriptions.



Figure D- 1 Power Distribution and Illumination System, Electrical (PDISE) Family

## MIL-HDBK-633A APPENDIX D

D.4.1.1. Power Distribution and Illumination System, Electrical (PDISE). The PDISE (and the original DISE used with DEPMEDS) is a set of man portable, reliable, modular, quick to assemble standardized electrical distribution system components. The PDISE provides power networks which can reduce the number of generator sets needed at a field location. The PDISE is not an end item (i.e. does not have an NSN), but a family of 5 end items, consisting of two feeder systems, two distribution systems and a utility receptacle and lighting system (each with an independent NSN), and associated auxiliary equipment. These items consist of cabling and circuit protection components which can be optimized (see [D.4.2](#)) to meet unique user applications. The [APPENDIX D](#) feeder systems and the 3-phase distribution system will subdivide and distribute 60 Hz, 3 phase, 120/208 volt power from a single power source to multiple 60 Hz, 120 volt, 1 phase or 120/208 volt, 3 phase equipment users within shelters and various unit complexes. The 60 amp single phase distribution system will distribute power from a 60 Hz, 120 V single phase generator set to multiple single phase users. The feeder and distribution system components interface with DoD standard MEPGS from 5 kW to 200 kW, as well as other power sources and components. Military standard connectors, receptacles and cabling supplemented with some hospital grade commercial receptacles are used throughout the systems. Cables for different phase and power ratings have unique connectors to prevent improper connections. The only exceptions are the pigtail cable, which is the primary interface to a generator set, and the universal adapter (see [Figure D- 8](#)). Extreme care should be taken to insure that the proper power characteristics are being provided by the pigtail connection or universal adapter.

D.4.1.2. Feeder System. The PDISE/DISE has two feeder systems, a 200 amp per phase system (M200) and a 100 amp per phase system (M100). Each system consists of a feeder center (circuit breaker box with military standard input and output connectors) with appropriate military standard connectors and military standard cabling that distributes the power from a 3-phase generator set to one or more 3 phase distribution systems.

D.4.1.3. Distribution System. The PDISE/DISE has two distribution systems. A three phase, 40 amp/phase distribution system (M40) consists of a housed circuit breaker system used to distribute 120/208 V, 3 phase power from a feeder system or smaller (5 kW -15 kW generator sets) to any 120/208 V, 3 phase loads and to 120V single phase loads. The single phase, 120 V, 60 amp (M60) distribution system was developed for applications which require up to 7.2 kW single phase power from a single phase generator set. It does not interface with either feeder system or the 40 amp distribution system. Both distribution systems interface with the utility receptacle and illumination kit.

D.4.1.4. Utility receptacle and illumination kit. The PDISE utility receptacle and illumination kit (M46) is a set of power cords, light sets and duplex boxes that can be connected to the feeder system to provide power and light to where it is needed. The PDISE utility receptacle and illumination kit has no self protection and should only be used with one of the PDISE distribution systems (i.e. M40 or M60). The PDISE utility receptacle and illumination kit provides internal tent and shelter wiring and lighting. The utility receptacles consist of hospital grade 120 volt "wall outlet" 20-ampere commercial receptacles.

D.4.1.5. Differences between systems. The primary difference between the PDISE and DISE systems is the circuit breakers. The PDISE uses hydraulic-magnetic circuit breakers and the DISE uses Thermal-magnetic circuit breakers. This difference also modifies the interior of the feeder and distribution centers but not the exteriors. In addition, the DISE utilizes ground fault protection circuit breakers on many of the 20 amp, single phase outputs.

### D.4.2. Utilization Considerations.

D.4.2.1. Application Planning. This Appendix is not a substitute for proper training and detailed manuals, but does provide information on the size and types of PDISE hardware to assist planners. The number and types of power generating sources available and the details of the users power requirements, such as where and how much power is needed, will be the driving factors in determining which and how many PDISE components are required. The PDISE system is flexible and no single solution is a "best" solution. Some possible component quantities are given in [Table D- II](#). A typical application is [APPENDIX D](#) presented in [Figure D- 7](#). The basis of issue for PDISE may not necessarily be one kilowatt of PDISE capability for each kilowatt of generator set capability. PDISE may be issued

## MIL-HDBK-633A APPENDIX D

based on the user's load dispersion needs. It should be recognized that in some applications the PDISE total power capability can be much less than the generator set kW rating and in others, it can be much greater, but in all cases it should disburse the power to where the user needs it within a 100 foot radius of the generator set (300 feet when using the M100 and M200 to feed power to the M40).

D.4.2.2. Safety. Grounding of a PDISE is through the mobile electric power generating source. Care must be taken to insure that an adequate and proper neutral to ground connection is provided at this point. The system neutral should only be connected to ground at this single point or ground currents (faults) can be created. If connection is made to a grounded shelter, care must be taken to insure that the neutral is not connected to ground at the shelter. All warning and caution notices as described in the manuals and posted on the hardware are intended to prevent serious injury or death. As previously noted, the system has unique connectors which can not be interconnected. The only exceptions are the pigtail cable which is the primary interface to a generator set and the universal adapter (see [D.4.1.1](#)). Extreme care should be taken to insure that the pigtail connection to the generator or within the universal adapter is made properly.

D.4.2.3. Voltage Drop Considerations. The voltage drop, caused by resistance in the cabling, will limit the distance to which the power can be distributed. Generally, full rated power can be distributed about 100 feet from a distribution center and up to 200 feet from a Feeder system for a total of about 300 feet. [Table D- III](#) provides voltage drops for various cable size and length combinations. The voltage drops tabulated are for rated current. Since voltage drops are proportional to the current, 50% of rated would produce 50% of the drop listed in the table.

D.4.2.4. Auxiliary Equipment. Since application of PDISE can vary greatly, additional components may have to be added to the system. A table of Auxiliary equipment is provided at [Table D- IV](#). These items may be used to tailor the PDISE to the user's requirements. The universal adapter, item 26 of [Table D- IV](#), is of particular value and is shown in [Figure D- 8](#). It is designed to connect electrical equipment, with a connection not supported by PDISE, to PDISE. It consists of a box with a three-phase 40/60 ampere input connector (for connection to the proper distribution center) and five terminals (for connecting the user's equipment with a user supplied cable). The universal adapter also enables users not having the required connectors for the 40 and 60 ampere outlets on the 100M and 200M Feeder systems, or the feed-thru on the 40 ampere Distribution system, to hook up to PDISE. Also note that a pneumatic crimping tool has been supplied to all direct support maintenance units in the Army. The pneumatic crimping tool gives the units the capability to repair damaged cables and connectors. Its use saves time and cost of ordering new cables.

D.4.2.5. Phase Balance. Phase balance must be considered when connecting single phase loads to a 3-phase generator. If a phase is unbalanced by more than 10% it can cause damage to the power generation source. The phase connections of the PDISE feeder and distribution centers are given in [Table D- V](#).

### D.5. DETAILED DESCRIPTIONS

D.5.1. Detailed Descriptions. Detailed descriptions are contained in the CHARACTERISTICS DATA SHEETS of [Table D- I](#) through [Table D- V](#). Data common to all PDISE components are contained in [Table D- VI](#).

**MIL-HDBK-633A  
APPENDIX D**

**200 Amp per Phase Feeder System - 3 Phase**

Used to distribute 3 phase power from 60, 100 and 200 kW generator sets.

	<b>PDISE</b>	<b>DISE</b>
Model	M200 A/P Electrical Feeder System	M200 Electrical Feeder System
Description	120/208V, 3 phase, 200 amp/phase. Includes feeder center, pigtail, feeder cable and carrying straps	Same but for DEPMEDS
NSN	6150-01-308-5672	6150-01-208-9755
LIN	F55488	same
SSN	R45500	same
Weight (lbs)	140	same
Circuit breakers	hydraulic-magnetic	Thermal-magnetic w/ground fault on 20 amp output
Dimensions	33.5"x 23.0"x 20.4", (9.1 ft <sup>3</sup> )	same



Figure D- 2 200 Amp per Phase Feeder System - 3 Phase

**MIL-HDBK-633A  
APPENDIX D**

**100 Amp per Phase Feeder System - 3 Phase**

Used to distribute 3 phase power from 30, 60, 100 and 200 kW generator sets.

	<b>PDISE</b>	<b>DISE</b>
Model	M100 A/P Electrical Feeder System	M100 Electrical Feeder System
Description	120/208 V, 3 phase, 100 amp/ ph. Includes feeder center, pigtail, feeder cable and carrying straps.	Same but for DEPMEDS
NSN	6150-01-308-5671	6150-01-208-9754
LIN	F55487	same
SSN	R45400	same
Weight (lbs)	77	same
Circuit breakers	hydraulic-magnetic	Thermal-magnetic w/ground fault on 20 amp output
Dimensions	24.3"x 22.4"x 20.4", ( 6.4 ft <sup>3</sup> )	same



1



2

**1 - Electrical Feeder Center:** 3-phase 120/208 V, 100 amp/ph, LIN F55621, NSN 6150-01-308-5671, Part Number 13226E7029, 1 ea

**2 - Service/Feeder Cable:** 50-ft (15.2m), 100-amp, 8-pin, NSN 6150-01-256-6304, Part Number 13226E7024, 2 ea

**3 - Cable Carrying Strap,** NSN 6150-01-256-6299, Part Number 13226E5825, 8 ea



4

**4 - Pigtail Cable:** 4-ft (1.2 m), 100-amp, 200-amp, 8-pin, NSN 6150-01-256-6300, Part Number 13226E7020, 1 ea

Figure D- 3 100 Amp per Phase Feeder System - 3 Phase

**MIL-HDBK-633A  
APPENDIX D**

**40 Amp per Phase Distribution System - 3 Phase**

Used to distribute power from 10 through 200 kW AC generator sets.

	<b>PDISE</b>	<b>DISE</b>
Model	M40 A/P Electrical distribution System	M40 Electrical Distribution System
Description	120/208 V, 3 phase, 40 amp/phase. Includes distribution center, cables, carrying straps, receptacles and storage container	Same but for DEPMEDS
NSN	6150-01-307-9446	6150-01-208-9753
LIN	F55485	same
SSN	R45300	same
Weight (lbs)	55	same
Circuit breakers	hydraulic-magnetic	Thermal-magnetic & ground fault on some 20 amp output
Dimensions	24.3"x 21.8"x 16.1", (4.9 ft <sup>3</sup> )	same



1



2



4

**1 – Distribution Center:** 3-phase, 120/208 V, 40-amp/ph, LIN F55485, NSN 6150-01-307-9446, Part Number 13226E7028, Dist Ctr Part Number 13229E6345, 1 ea

**2 – Service/Feeder Cable:** 100-ft (30.48m), 40/60-amp, 3-pin, NSN 6150-01-247-4761, Part Number 13226E7023-2, 1 ea

**3 – Cable Carrying Strap,** NSN 6150-01-256-6299, Part Number 13227E5825, 16 ea

**4 - Pigtail Cable:** 4-ft (1.2m), 40/60-AMP, 3-pin, NSN 6150-01-256-6301, part Number 13226E7019, 1 ea



**Transit and Storage Container,** NSN 6150-01-256-6298, Part Number 13227E5830, 1 ea  
Packaging List, Part Number 13227E5826

**Box Receptacle,** 120 V, 20-amp, NSN 6150-01-251-9125, Part Number 13226E7040, 1 ea

**Extension Cable,** 25-ft (7.6 m), 20-amp, 3-pin, NSN 6150-01-250-0044, Part Number 13226E7032-2, 3 ea

**Extension Cable,** 50-ft (15.2 m), 20-amp, 3-pin, NSN 6150-01-250-3643, Part Number 13226E7032-1, 3 ea

**Utility Light,** PN# 13226E7043, 2 ea

**Light Bulb Container,** PN# 132275829, 3 ea  
Blue, 40 Watt, PN# W-L-101/68, 3 ea  
White, 75 Watt, PN# W-L-101/85, 3 ea

Figure D- 4 40 Amp per Phase Distribution System - 3 Phase

Photo is of Three Phase Family of PDISE components and includes 200 and 100 amp feeder centers and 40 amp distribution center.

**MIL-HDBK-633A  
APPENDIX D**

**60 Amp Distribution System - Single Phase**

Used to distribute single phase power from 5 through 15 kW AC generator sets and single phase output from feeder systems.

	<b>PDISE</b>	<b>DISE</b>
Model	M60 A/P Electrical Distribution System	M60 Electrical Distribution System
Description	120 V, 1 phase, 60 amp dist center and associated components	Same but for DEPMEDS
NSN	6150-01-307-9445	6150-01-208-9752
LIN	F55553	same
SSN	R45200	same
Weight (lbs)	45	same
Circuit breakers	hydraulic-magnetic	Thermal-magnetic w/ground fault on some 20 amp output
Dimensions	24.3"x 21.8"x 15.5", (4.7 ft <sup>3</sup> )	same

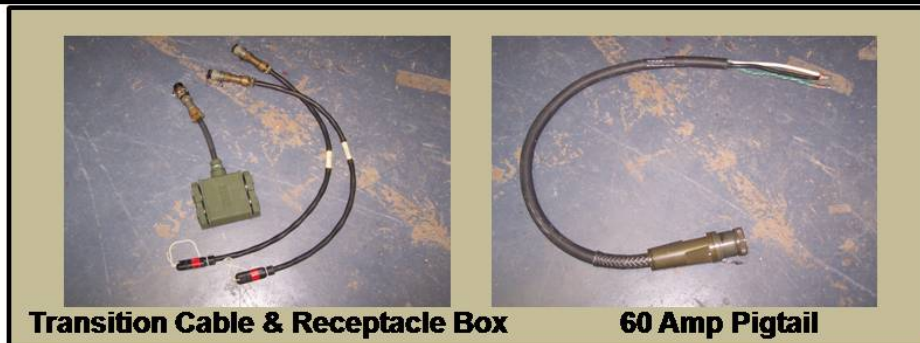

Figure D- 5 60 Amp Distribution System - 1 Phase

**MIL-HDBK-633A  
APPENDIX D**

**Utility Receptacles and Lighting Set**

Used to distribute single phase power to lighting and electrical receptacles from distribution systems.

	<b>PDISE and DISE</b>
Model	M46 Electrical Utility Kit
Description	Extension cords, utility receptacles and lighting sets
NSN	6150-01-208-9751
LIN	U89185
SSN	R62800
Weight (lbs)	85
Dimensions	16.0"x 16.0" x 26.0", (3.9 ft <sup>3</sup> )



**1 – Transit and Storage Container**, LIN U89185, NSN 6150-01-208-9751, Part Number 13229E6362, 1 ea

**2 - Receptacle Box**: 120 V, 20-amp, NSN 6150-01-251-9125, part Number 13226E7040, 6ea

**3 – Cable Securing Strap**, NSN 6150-01-250-0045, Part Number 13226E7044, 6 ea

**4 – Support Rope Assembly**, 53-h (1.2m), NSN 6150-01-256-6302, Part Number 13226E7041, 2 ea

**5 – Light Bulb Kit**: NSN 6150-01-264-2068, Part Number 13227E5829, 3 ea  
 40 W, **Blue**, NSN 6240-00-617-1 744, Part Number W-L-I 01/68, 3 ea  
 75 W, **White**, NSN 6240-00-689-8504, Part Number 40A/B-120V, 3 ea

**6 – Utility Light**, 120 V, dual socket, incandescent, NSN 6230-01-247-4784, Part Number 13226E7043, 2 ea

**7 – Extension Cables**, NSN 6150-01-247-4766, Part Number 13226E7032-3, 6 ea

**8 – Branch Circuit Cable Assembly**: 24-h (7.3m), 20-amp, 3-pin, NSN 6150-01-251-9124, Part Number 13226E7034, 2 ea

**9. Fluorescent Utility Light** : NSN 6230-01-465-8931, 2 ea, Part Number: 13230E7018

Figure D- 6 Utility Receptacles and Lighting Set



MIL-HDBK-633A  
APPENDIX D

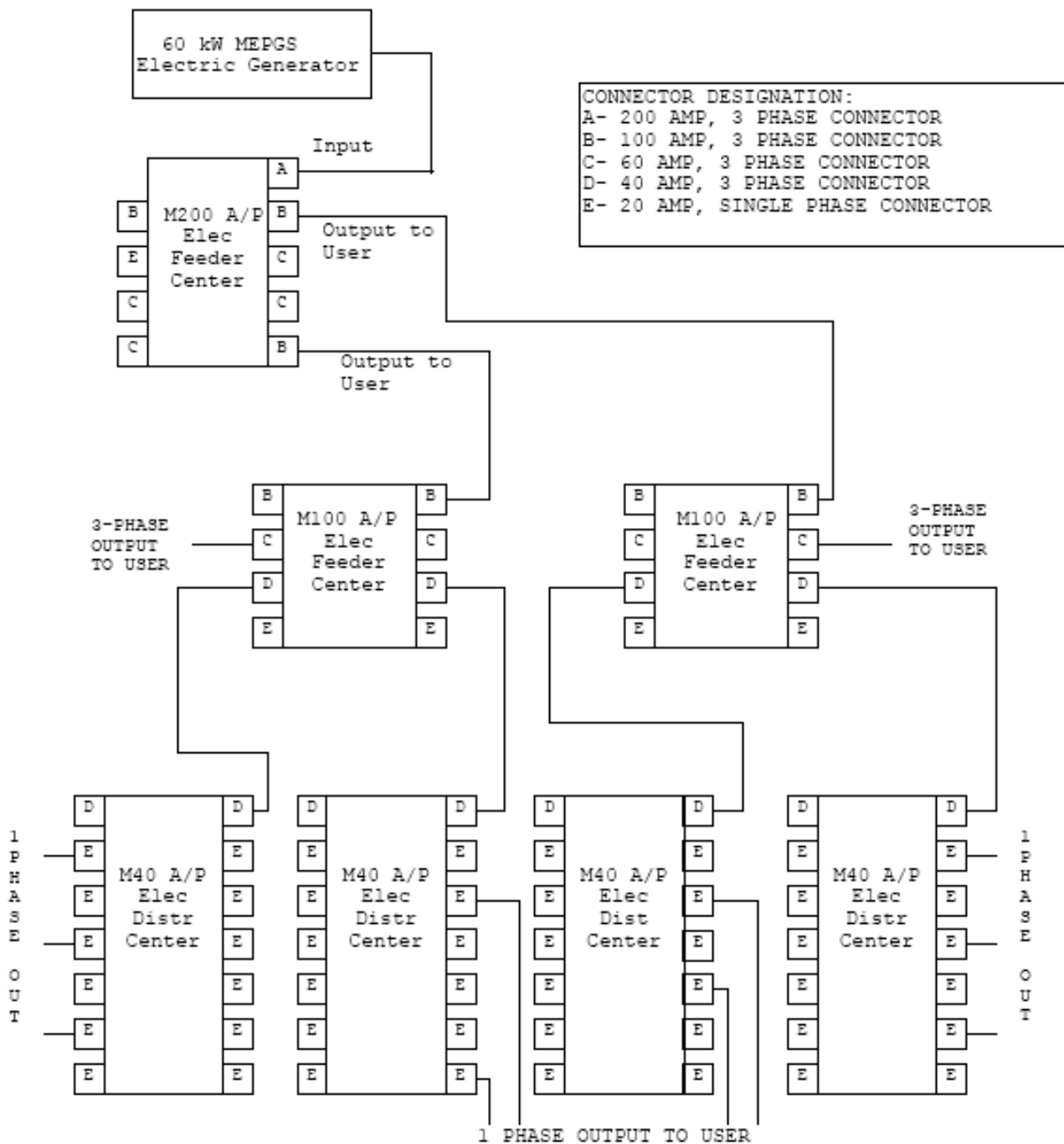

Figure D- 7 Sample of a possible distribution arrangement

MIL-HDBK-633A  
APPENDIX D

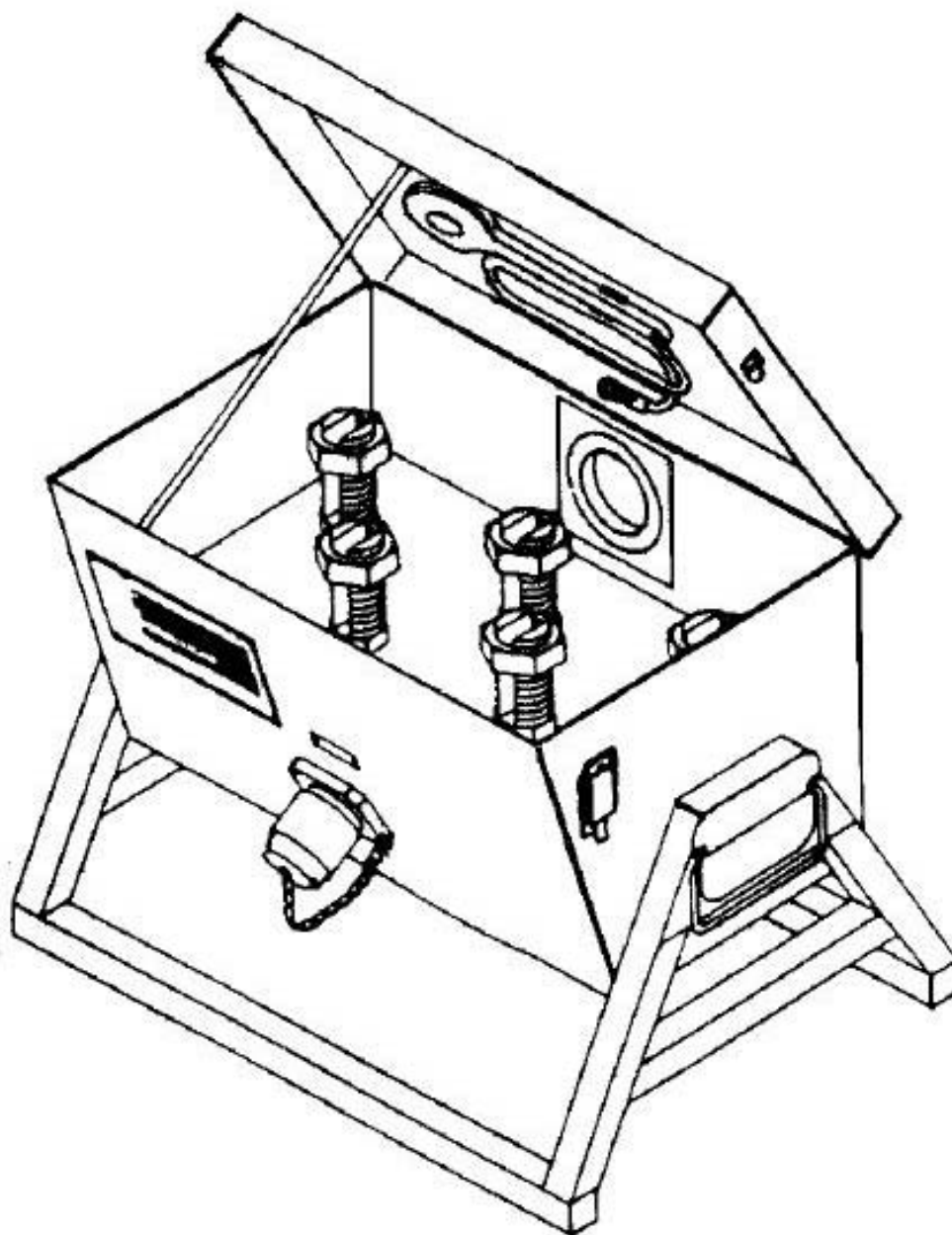

Figure D- 8 Universal Adapter

**MIL-HDBK-633A  
APPENDIX D**

Table D- II Some PDISE - generator applications

Generator kW	M200/ M200A/P	M100/ M100A/P	M40/ M40A/P	M60/ M60A/P	M46	# of phases
5				1	3	1
10				1	3	1
10			1		6	3
15				3	9	1
15			1		6	3
30			2		12	3
30		1	1		6	3
60		2	4		24	3
60	1	2	2		12	3
100		3	6		36	3
100	2	4	8		48	3
200	3	6	12		72	3

(Possible quantities of PDISE components shown)

Table D- III Approximate voltage losses at rated amperage\*

Rated amperage/no. of pins	Cable length in feet					
	15	25	50	100	200	300
200 amp/8 pin cables (3-ph)	1 V	1.6 V	3.2 V	6.4 V	12.8 V	19.2 V
100 amp/8 pin cables (3-ph)	0.4 V	0.7 V	1.4 V	2.8 V	5.6 V	8.4 V
60 amp/5 pin cables (3-ph)	0.5 V	0.9 V	1.6 V	3.5 V	6.4 V	10.5 V
40 amp/5 pin cables (3-ph)	0.3 V	0.6 V	1.1 V	2.3 V	4.4 V	6.9 V
60 amp/4 pin cables (1-ph)	0.5 V	0.9 V	1.7 V	3.4 V	6.8 V	10.2 V
20 amp/3 pin cables (1-ph)	1.1 V	1.8 V	3.6 V	7.2 V	14.4 V	21.6 V

\* actual voltage drop will be affected by temperature and the quality of the connection made when mating the connectors (dirt, corrosion, and oil affect pin resistance).

**MIL-HDBK-633A  
APPENDIX D**

Table D- IV Auxiliary equipment

	<b>Extras of existing PDISE components Item Description</b>	<b>Weight lb</b>	<b>NSN</b>
1	Branch circuit cable, 8 ft, 20 amp, 3 pin	2	6150-01-250-5644
2	Branch circuit cable, 16 ft, 20 amp, 3 pin	4	6150-01-256-6297
3	Branch circuit cable, 24 ft, 20 amp, 3 pin	6	6150-01-251-9124
4	Cable carrying strap	negligible	
5	Cable securing strap	negligible	
6	Container, transit and storage		6150-01-256-6298
7	Duplex receptacle, 120 V, 20 amp		6150-01-251-9125
8	Extension cable, 3.5 ft, 20 amp, 3 pin	0.7	6150-01-258-1253
9	Extension cable, 15 ft, 20 amp, 3 pin	3	6150-01-247-4766
10	Extension cable, 25 ft, 20 amp, 3 pin	5	6150-01-250-0044
11	Extension cable, 50 ft, 20 amp, 3 pin	10	6150-01-250-3643
12	Florescent light, 4 ft, 120 V, single tube		6150-01-250-0046
13	Container, light bulb kit, 2-bulb		6150-01-256-2068
14	Pigtail cable, 4 ft, 40/60 amp, 5 pin	5	6150-01-256-6301
15	Pigtail cable, 4 ft, 60 amp, 4 pin	4	6150-01-247-4778
16	Pigtail cable, 4 ft, 100 amp, 8 pin	17	6150-01-256-6300
17	Pigtail cable, 4 ft, 200 amp, 8 pin	28	6150-01-247-4768
18	Rope support assembly, 53 ft		6150-01-256-6302
19	Service/feeder cable, 25 ft, 40/60 amp, 5 pin	27	6150-01-247-4780
20	Service/feeder cable, 25 ft, 200 amp, 8 pin	136	6150-01-247-4782
21	Service/feeder cable, 50 ft, 40/60 amp, 5 pin	53	6150-01-247-4781
22	Service/feeder cable, 50 ft, 60 amp, 4 pin	48	6150-01-256-6303
23	Service/feeder cable, 50 ft, 100 amp, 8 pin	100	6150-01-256-6304
24	Service/feeder cable, 100 ft, 40/60 amp, 5 pin	105	6150-01-247-4779
25	Service/feeder cable, 100 ft, 60 amp, 4 pin	96	6150-01-247-4793
26	Universal adapter		5975-01-247-4791
27	Utility light, 120 V, dual socket, incandescent		6230-01-247-4784
28	Interface cable, 40/60 amp, 5-ton expando van		6150-01-250-3564
29	Interface cable, 20 amp, general illumination lighting set		6150-01-256-4290
30	Cable carrying strap (double), 200 amp		
31	Fluorescent Utility Light		6230-01-465-8931

**MIL-HDBK-633A  
APPENDIX D**

Table D- V Connector to phase links

Center	Connector:	Phase	A	B	C	N
			L1	L2	L3	
<b>200 amp feeder center - M200 A/P &amp; M200</b>						
J-1	200 amp input (120/208 V, 3 phase)		x	x	x	x
J-4	100 amp output (120/208 V, 3 phase)		x	x	x	x
J-5	100 amp output (120/208 V, 3 phase)		x	x	x	x
J-6	20 amp output (120 V, 1 phase)(GF on M200)*			x		x
J-7	60 amp output (120/208 V, 3 phase)		x	x	x	x
J-8	60 amp output (120/208 V, 3 phase)		x	x	x	x
J-9	60 amp output (120/208 V, 3 phase)		x	x	x	x
J-10	60 amp output (120/208 V, 3 phase)		x	x	x	x
J-11	100 amp output (120/208 V, 3 phase)		x	x	x	x
<b>100 amp feeder center - M100 A/P &amp; M100</b>						
J-1	100 amp input (120/208 V, 3 phase)		x	x	x	x
J-2	100 amp output (120/208 V, 3 phase)		x	x	x	x
J-3	60 amp output (120/208 V, 3 phase)		x	x	x	x
J-4	40 amp output (120/208 V, 3 phase)		x	x	x	x
J-5	40 amp output (120/208 V, 3 phase)		x	x	x	x
J-6	60 amp output (120/208 V, 3 phase)		x	x	x	x
J-7	20 amp output (120 V, 1 phase)(GF on M100)				x	x
J-8	20 amp output (120 V, 1 phase)(GF on M100)		x			x
<b>40 amp distribution center - M40 A/P &amp; M40</b>						
J-1	40 amp input (120/208 V, 3 phase)		x	x	x	x
J-2	40 amp output (120/208 V, 3 phase)		x	x	x	x
J-3	20 amp output (120 V, 1 phase)(GF on M40)				x	x
J-4	20 amp output (120 V, 1 phase)				x	x
J-5	20 amp output (120 V, 1 phase)(GF on M40)			x		x
J-6	20 amp output (120 V, 1 phase)			x		x
J-7	20 amp output (120 V, 1 phase)(GF on M40)		x			x
J-8	20 amp output (120 V, 1 phase)		x			x
J-9	20 amp output (120 V, 1 phase)(GF on M40)				x	x
J-10	20 amp output (120 V, 1 phase)				x	x
J-11	20 amp output (120 V, 1 phase)(GF on M40)			x		x
J-12	20 amp output (120 V, 1 phase)			x		x
J-13	20 amp output (120 V, 1 phase)(GF on M40)		x			x
J-14	20 amp output (120 V, 1 phase)(GF on M40)		x			x
<b>60 amp distribution center - M60 A/P &amp; M60</b>						
J-1	60 amp input (120 V, 1 phase)		x			x
J-2	60 amp output (120 V, 1 phase)		x			x
J-3	20 amp output (120 V, 1 phase)(GF on M60)		x			x
J-4	20 amp output (120 V, 1 phase)		x			x
J-5	20 amp output (120 V, 1 phase)(GF on M60)		x			x
J-6	20 amp output (120 V, 1 phase)		x			x
J-7	20 amp output (120 V, 1 phase)(GF on M60)		x			x
J-8	20 amp output (120 V, 1 phase)		x			x

\* GF - ground fault protection.

Table D- VI Common characteristics of PDISE/DISE

Environmental Capability	-25°F to 120°F, rain, humidity, sand/dust, cold storage -65°F, salt spray, fungus. Note any special procedures in the manual.
Human Factors	MIL-STD-1474. Man portable and operable in 4 hours after arrival at site.
Auxiliary Equipment:	Extra DISE/PDISE components may be requisitioned on an as required basis to meet particular needs. See <a href="#">Table D-III</a> .
Technical Manuals:	OPERATOR, UNIT and DIRECT SUPPORT MAINT: ARMY: TM 9-6150-226-13 REPAIR PARTS AND SPECIAL TOOLS LIST: TM 9-6150-226-23P

**MIL-HDBK-633A**  
**APPENDIX D**

This Page Intentionally Left Blank

**MIL-HDBK-633A  
APPENDIX E**

**STANDARD MEPGS AND ASSOCIATED POWER UNITS AND POWER PLANTS NO LONGER  
PROCURABLE BUT REMAIN IN INVENTORY**

**E.1 SCOPE**

E.1.1 Scope. This Appendix identifies members of the DoD Standard Family of MEPGS that are no longer procurable but remain supportable. Also included are standard trailer mounted (Power Unit (PU)/Power Plant (PP)) configurations of these items. Data contained in this Appendix is for information only and is provided to assist both field operation and materiel developer personnel to select the power generation source that will best meet their needs. Procurable MEPGS from [APPENDIX A](#) are preferred to the sets identified in this Appendix but if the items of Appendix A are unavailable then these power sources may be used to meet power needs. DoD activities are to utilize these power sources to the maximum extent practicable per DoD DIRECTIVE 4120.11.

Table E- I Guide to CHARACTERISTICS DATA SHEETS of APPENDIX E

<b>MODEL NO.</b>	<b>ITEM DESCRIPTION</b>	<b>NSN</b>	<b>FIG</b>	<b>PAGE</b>
MEP-019A	0.5 kW, 400 Hz, GED, Tactical Utility unmodified	6115-00-940-7862	Figure E- 1	98
MEP-015A	1.5 kW, 60 Hz, GED, Tactical Utility unmodified	6115-00-889-1446	Figure E- 2	100
MEP-025A	1.5 kW, 28 VDC, GED, Tactical Utility unmodified	6115-00-017-8236	Figure E- 2	100
MEP-016A	3 kW, 60 Hz, GED unmodified	6115-00-017-8237	Figure E- 3	102
MEP-016C	3 kW, 60 Hz, GED, modified	6115-01-143-3311	Figure E- 3	102
MEP-021A	3 kW, 400 Hz, GED, Tactical Utility unmodified	6115-00-017-8238	Figure E- 3	102
MEP-021C	3 kW, 400 Hz, GED, Tactical Utility modified	6115-01-175-7321	Figure E- 3	102
MEP-026A	3 kW, 28 VDC, GED, Tactical Utility unmodified	6115-00-017-8239	Figure E- 3	102
MEP-026C	3 kW, 28 VDC, GED, Tactical Utility modified	6115-01-175-7320	Figure E- 3	102
MEP-016B	3 kW, 60 Hz, DED, TU, without ASK	6115-01-150-4140	Figure E- 4	104
MEP-701A	3 kW, 60 Hz, DED with ASK	6115-01-234-5966	Figure E- 4	104
AN/MJQ-32	Power Plant, DED, 3 kW, 60 Hz TRLMTD	6115-01-280-2300	Figure E- 5	106
AN/MJQ-33	Power Plant, DED, 3 kW, 60 Hz TRLMTD	6115-01-280-2301	Figure E- 6	107
MEP-017A	5 kW, 60 Hz, GED, Tactical Utility	6115-00-017-8240	Figure E- 7	108
MEP-022A	5 kW, 400 Hz, GED, Tactical Utility	6115-00-017-8241	Figure E- 7	108
MEP-002A	5 kW, 60 Hz, DED, Tactical Utility	6115-00-465-1044	Figure E- 8	110
PU-751/M	Generator Set, DED, 5 kW, 60 Hz, TRLMTD	6115-00-033-1373	Figure E- 9	112
PU-797	Generator Set TQG, 5 kW, 60 Hz TRLMTD	6115-01-332-0741	Figure E- 10	113
AN/MJQ-16	Power Plant, DED, 5 kW, 60 Hz TRLMTD	6115-00-033-1395	Figure E- 11	114
AN/MJQ-35	Power Plant, TQG, 5 kW, 60 Hz TRLMTD	6115-01-313-4216	Figure E- 12	115
MEP-003A	10 kW, 60 Hz, DED, Tactical Utility	6115-00-465-1030	Figure E- 13	116
MEP-112A	10 kW, 400 Hz, DED, Tactical Utility	6115-00-465-1027	Figure E- 13	116
PU-753/M	Generator Set, DED, 10 kW, 60 Hz, TRLMTD	6115-00-033-1389	Figure E- 14	118
PU-798	10 kW TQ Power Unit, 60 Hz, TRLMTD	6115-01-319-9032	Figure E- 15	119
PU-799	10 kW TQ Power Unit, 400 Hz, TRLMTD	6115-01-313-4283	Figure E- 16	120
AN/MJQ-18	Power Plant, DED, 10 kW, 60 Hz TRLMTD	6115-00-033-1398	Figure E- 17	121
AN/MJQ-25	Power Plant, DED, 10 kW, 400 Hz TRLMTD	6115-01-153-7742	Figure E- 18	122
MEP-018A	10 kW, 60 Hz, GED, Tactical Utility	6115-00-889-1447	Figure E- 19	123
MEP-023A	10 kW, 400 Hz, GED, Tactical Utility	6115-00-926-0843	Figure E- 19	123
MEP-004A	15 kW, 50/60 Hz, DED, Tactical Utility	6115-00-118-1241	Figure E- 20	125
MEP-113A	15 kW, 400 Hz, DED, Tactical Precise	6115-00-118-1244	Figure E- 20	125
PU-405A/M	Gen Set, DED, 15 kW, 50/60 Hz, TRLMTD	6115-00-394-9577	Figure E- 21	127
PU-732/M	Generator Set, DED, 15 kW, 400 Hz, TRLMTD	6115-00-260-3082	Figure E- 22	128
PU-800	15 kW TQ POWER UNIT, 400 Hz, TRLMTD	6115-01-317-2137	Figure E- 23	129
PU-801	15 kW TQ POWER UNIT, 50/60 Hz, TRLMTD	6115-01-319-9033	Figure E- 24	130
PU-801A	15 kW TQ POWER UNIT, 50/60 Hz, TRLMTD	6115-01-413-3821	Figure E- 25	131
PU-802	15 kW TQ POWER UNIT, 50/60 Hz, TRLMTD	6115-01-317-2138	Figure E- 26	132
AN/MJQ-15	Power Plant, DED, 15 kW, 400 Hz TRLMTD	6115-00-400-7591	Figure E- 27	133
AN/MJQ-39	15kW TQ POWER PLANT, 400 Hz, TRLMTD	6115-01-299-6034	Figure E- 28	134
AN/MJQ-48	15kW TQ POWER PLANT, 50/60 Hz, TRLMTD	6115-01-540-8433	Figure E- 29	135
AN/MJQ-48A	15kW TQ POWER PLANT, 50/60 Hz, TRLMTD	6115-01-540-9465	Figure E- 30	136
MEP-005A	30 kW, 50/60 Hz, DED, Tactical Utility	6115-00-118-1240	Figure E- 31	137
MEP-114A	30 kW, 400 Hz, DED, Tactical Precise	6115-00-118-1248	Figure E- 31	137

**MIL-HDBK-633A  
APPENDIX E**

MODEL NO.	ITEM DESCRIPTION	NSN	FIG	PAGE
PU-406B/M	Gen Set, DED, 30 kW, 50/60 Hz, TRLMTD	6115-00-394-9576	Figure E- 32	139
PU-760/M	Generator Set, DED, 30 kW, 400 Hz, TRLMTD	6115-00-394-9581	Figure E- 33	140
PU-803	TQ PU,DED,30kW, 50/60Hz,TRLMTD	6115-01-317-2136	Figure E- 34	141
PU-804	TQ POWER UNIT, DED,30kW,400Hz, TRLMTD	6115-01-317-2135	Figure E- 35	142
AN/MJQ-10A	Power Plant, DED, 30 kW, 50/60 Hz TRLMTD	6115-00-394-9582	Figure E- 36	143
AN/MJQ-40	TQ Power Plant,DED, 30kW,50/60 Hz,TRLMTD	6115-01-299-6033	Figure E- 37	143
MEP-006A	60 kW, 50/60 Hz, DED, Tactical Utility	6115-00-118-1243	Figure E- 38	144
MEP-115A	60 kW, 400 Hz, DED, Tactical Precise	6115-00-118-1253	Figure E- 38	144
PU-650B/G	Gen Set, DED, 60 kW, 50/60 Hz, TRLMTD	6115-00-258-1622	Figure E- 39	147
PU-707A/M	Generator Set, DED, 60 kW, 400 Hz, TRLMTD	6115-00-394-9573	Figure E- 40	148
PU-805	TQ POWER UNIT,DED,60kW,50/60Hz,TRLMTD	6115-01-317-2134	Figure E- 41	149
PU-806	TQ POWER UNIT, DED, 60kW,400 Hz,TRLMTD	6115-01-317-2133	Figure E- 42	150
AN/MJQ-12A	Power Plant, DED, 60 kW, 50/60 Hz TRLMTD	6115-00-257-1602	Figure E- 43	151
AN/MJQ-41	TQ Power Plant,DED,60kW,50/60Hz,TRLMTD	6115-01-303-7896	Figure E- 44	151
MEP-007B	100 kW, 50/60 Hz, DED, Tactical Utility	6115-01-036-6374	Figure E- 45	153
PU-495B/G	Gen Set, DED, 100 kW, 50/60 Hz, TRLMTD	6115-01-134-0165	Figure E- 46	155
MEP-108A	200 kW, 50/60 Hz, DED, Tactical Precise	6115-00-935-8729	Figure E- 47	156
MEP-009A	200 kW, 50/60 Hz, DED, Tactical Utility	6115-00-133-9104	Figure E- 47	156
MEP-009B	200 kW, 50/60 Hz, DED, Tactical Utility	6115-01-021-4096	Figure E- 48	158
AN/MJQ-11A	Power Plant, DED, 200 kW, 50/60 Hz, TRLMTD	6115-00-394-9583	Figure E- 49	160
MEP-029A	500 kW, 50/60 Hz, DED, Tactical Utility	6115-01-030-6085	Figure E- 50	161
MEP-012A	750 kW, 50/60 Hz, DED, PU	6115-01-143-3850	Figure E- 51	163
MEP-208A	750 kW, 50/60 Hz, DED, PU	6115-00-450-5881	Figure E- 52	165

E.1.1 Appendix Organization. This Appendix is a compilation of characteristics data sheets (see [Table E- I](#)) arranged by power rating capacity. Within a power rating, standard skid mounted power generating sources are listed first followed by standard trailer mounted variants.

## E.2 APPLICABLE DOCUMENTS

This section is not applicable to this Appendix.

## E.3 DEFINITIONS

E.3.1 Use definitions of basic document.

## E.4 GENERAL DESCRIPTION

### E.4.1 General.

E.4.1.1 Gasoline engine-driven (GED) generator sets. Gasoline engine-driven generator sets were developed in the 0.5 to 10 kW power range. Since gasoline is no longer a logistics fuel that will be supported on the modern battlefield, these sets have been phased out as diesel fueled units become available to replace them.

E.4.1.2 Diesel engine-driven (DED) generator set. There are no planned additional procurements for diesel engine-driven generator sets listed in this Appendix. They have been replaced by the generator sets being procured and/or developed as listed in APPENDIX A.

E.4.1.3 Trailer mounted configurations. Several trailers are used in Power Unit and Power Plant MEPGS systems depending on size, weight and configuration. The PU/PPs of this Appendix have been phased out as sufficient quantities of units from APPENDIX A become available. A list of trailers follows.

a. M116A3. The M116A3 is a 3/4 ton trailer modified to carry the extra weight of a generator set and its associated hardware. The mobility is sufficient to allow lower speed access to areas accessible to a HMMWV.



**MIL-HDBK-633A**  
**APPENDIX E**

b. M103A4. The M103A4 is a 1-1/2 ton trailer modified to carry the extra weight of a generator set and its associated hardware.

c. M200A1. The M200A1 is a 2-1/2 ton trailer modified to carry the extra weight of a generator set and its associated hardware.

E.4.2 Delivered condition.

This information is provided as a historical record. These items are not longer available.

E.5 DETAILED DESCRIPTIONS

E.5.1 Detailed Descriptions. Detailed descriptions are contained in the CHARACTERISTICS DATA SHEETS of [Figure E- 1](#) through [Figure E- 52](#).

**MIL-HDBK-633A  
APPENDIX E**

**0.5 kW, GED, 400 Hz Generator Set**

<b>Identification Data</b>			
Description	0.5 kW, GED, 400 Hz Generator Set		
Model Number	MEP-019A		
NSN	6115-00-940-7862		
LIN	J43027		
Configuration	Tubular frame skid.		
<b>Physical Characteristics</b>			
Dimensions LWH (in)	19.6 x 17.0 x 17.0 (Cube: 3 ft <sup>3</sup> )		
Dry Weight (lbs)	85		
Engine	1 cylinder gasoline, 1.5 hp @ 3428 RPM, rope start, air cooled.		
Fuels	Automotive gasoline, emergency - aviation gasoline		
Fuel Capacity	1 gal		
Instrumentation	Voltmeter		
<b>Performance Characteristics</b>			
Power Rating	0.5 kW @ 1.0 pf from -25°F to 125°F/MSL, 107°F/5000 ft, 95°F/8000 ft.		
Environmental Capability	rain, humidity, altitude, sand/dust, transportation, 3 foot drop, vibration, 65°F cold storage, salt spray, fungus. Operable at incline to 15%.		
Protective Devices	None		
Fuel Consumption	0.25 gal/hour @ rated load.		
Human Factors	MIL STD1474.		
Noise	Man portable. 76 dBA @ 25 ft.		
Reliability (MTBF)	250 hr (specified).		
<b>Electrical Characteristics</b>			
Voltage Connection:	120 V, 400 Hz, 1 phase, 2 wire.		
Adjustment Range	114 V to 126 V		
Electrical	Drip proof generator enclosure, fungus & moisture treated, solid state voltage regulator, brushless rotary exciter.		
<b>Electrical Performance</b>			
<b>Electric Power Quality</b>	<b>Voltage</b>	<b>Frequency</b>	
Short term steady state stability (30 sec)	2% bandwidth	4% bandwidth	
Long term steady state stability (4 hr)	2% bandwidth	4% bandwidth	
Application/rejection of rated load, recovery time	30% under/over, 2 sec	3% under/5% over, 4 sec/6 sec	
Max waveform deviation factor	8%		
Individual waveform harmonic	5%		
Regulation	4%	3%	
EMI	Suppressed to MIL-STD-461 limits..		
EMP	Not protected		
<b>Optional Equipment</b>			
<b>Description</b>	<b>NSN</b>	<b>Weight (lbs)</b>	<b>Effect on Dim.(in)</b>
Canvas cover	6115-00-990-8770	4	negligible
Spark Arrester kit	2990-01-032-0755		none
<b>Technical Manuals:</b>			
<b>Army</b>	<b>Air Force</b>	<b>Marine Corps</b>	<b>Navy</b>
TM5-6115-329-14	TO35C2-3-440-1	TM 81283-14	P-8-611E
TM5-2805-256-14	TO35C2-102-2	SL-4-81283B	
TM5-2805-256-24P	TO35C2-102-4		
LO 5-2805-256-12			

MIL-HDBK-633A  
APPENDIX E



MEP-019A

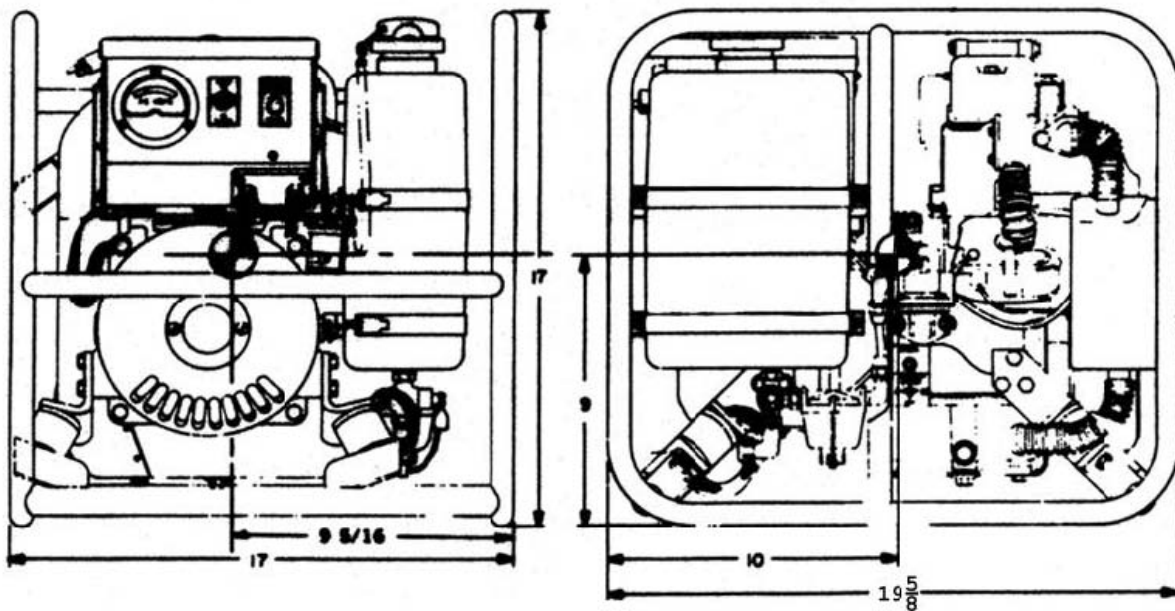

Figure E- 1 0.5 kW, GED, 400 Hz Generator Set

**MIL-HDBK-633A  
APPENDIX E**

**1.5 kW, GED, Generator Set**

<b>Identification Data</b>			
Nomenclature	1.5 kW, 60 Hz, GED, Tactical Utility	1.5 kW, 28 VDC, GED, Tactical Utility	
Model Number	MEP-015A	MEP-025A	
NSN	6115-00-889-1446	6115-00-017-8236	
LIN	J43918	J44056	
Configuration	Tubular frame skid, lifting attachments provided.		
<b>Physical Characteristics</b>			
Dimensions LWH (in)	27.3 x 20.3 x 18.5. (Cube: 6 ft <sup>3</sup> ).		
Dry Weight (lbs)	125	125	
Engine	2 cylinder gasoline, 3 hp @ 3600 RPM, rope start, air cooled.		
Fuels	Automotive gasoline, emergency - aviation gasoline;		
Fuel Capacity	1.5 gal.		
Instrumentation	AC: voltmeter, frequency meter, DC: ammeter, voltmeter.		
<b>Performance Characteristics</b>			
Electric Power Rating	1.5 kW @ 1.0 pf from -25°F to: 125°F/MSL, 107°F/ 5000 ft, 95°F/8000 ft.		
Environmental Capability	rain, humidity, altitude, sand/dust, transportation, 3 foot drop, vibration, cold storage: -45°F, salt spray, fungus. Operable at incline to 15%.		
Protective Devices	DC: Overload, short circuit.		
Fuel Consumption	0.54 gal/hour @ rated load.		
Human Factors	MIL-STD-1474. Man portable.		
Noise	78 dBA @ 25 ft.		
Reliability (MTBF)	250 hr (specified).		
<b>Electrical Characteristics</b>			
Connection	120V, 1 ph, 2 wire	240V, 1 ph, 2 wire	28 VDC, 2 wire
Voltage Adj Range	114 to 126 V	228 to 252 V	26.6 - 29.4 V
Electrical	Drip proof generator enclosure, fungus & moisture treated, solid state voltage regulator, brushless rotary exciter.		
<b>Electrical Performance</b>			
<b>Electric Power Quality</b>	<b>AC Voltage</b>	<b>Frequency</b>	<b>DC Voltage</b>
Short term steady state stability (30 sec)	2% bandwidth	4% bandwidth	2% bandwidth
Long term steady state stability (4 hr)	2% bandwidth	4% bandwidth	2% bandwidth
Application/rejection of rated load, recovery time	30% dip/rise, 2 sec	3% dip/5% rise, 4 sec/ 6 sec	30% dip/40% rise, 2 sec
Max waveform deviation factor	8%		
Individual waveform harmonic	5%		
DC ripple			5.5%
Regulation	4% - 120 V 5% - 240 V	3%	4%
EMI	Suppressed to MIL-STD-461 limits.		
EMP	Not protected.		
<b>Optional Equipment</b>			
<b>Description</b>	<b>NSN</b>	<b>Weight (lbs)</b>	<b>Effect on Dim.(in)</b>
Canvas cover	6115-00-941-1655	5	negligible
Spark arrester kit	2990-01-032-0755		none
<b>Technical Manuals</b>			
<b>Army</b>	<b>Air Force</b>	<b>Marine Corps</b>	<b>Navy</b>
TM5-6115-323-14	TO35C2-3-385-1	SL4-07609A/07610A	P-8-612E
TM5-6115-323-15	TO35C2-3-385-11	TM 81283-14	
TM5-6115-323-24P	TO35C2-3-385-4	SL4-81283B	
TM5-2805-257-14	TO38G2-103-2		
TM5-2805-257-24P	TO38G2-103-4		

MIL-HDBK-633A  
APPENDIX E



MEP-015A

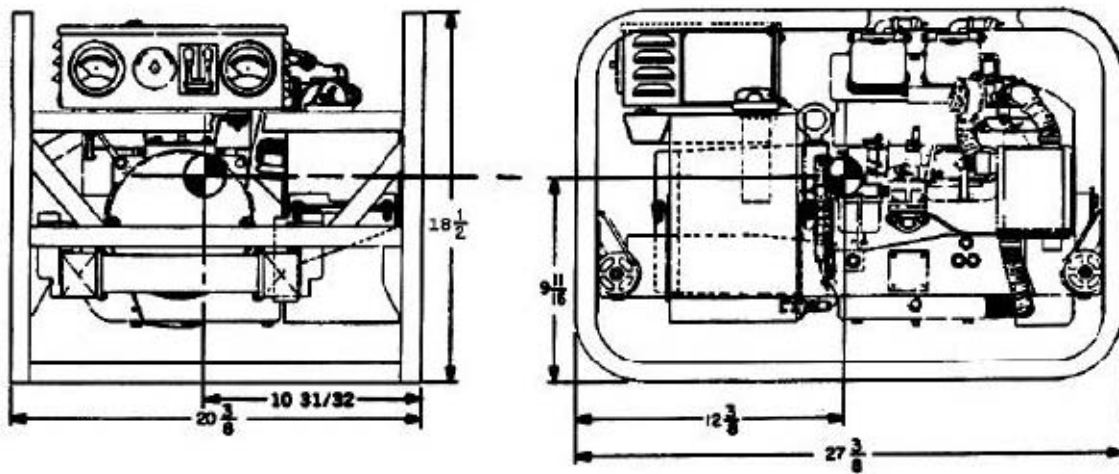

MEP-025A

Figure E- 2 1.5 kW, GED, Generator Set

**MIL-HDBK-633A  
APPENDIX E**

**3 kW, GED, Generator Set (Diesel conversion kit is available to Reserves)**

Identification Data			
Nomenclature	3 kW, 60 Hz, GED, TU	3 kW, 60 Hz, GED, TU mod	
Model Number	MEP-016A	MEP-016C	
NSN	6115-00-017-8237	6115-01-143-3311	
LIN	J45699	J45699	
Nomenclature	3 kW, 400 Hz, GED, TU	3 kW, 400 Hz, GED, TU mod	
Model Number	MEP-021A	MEP-021C	
NSN	6115-00-017-8238	6115-01-175-7321	
LIN	J45836	J45836	
Nomenclature	3 kW, DC, GED, TU	3 kW, DC, GED, TU mod	
Model Number	MEP-026A	MEP-026C	
NSN	6115-00-017-8237	6115-01-143-3311	
LIN	J46110	J46110	
Configuration	Tubular frame skid, lifting attachments provided.		
Physical characteristics			
Dimensions LWH(in)	35.0 x 23.8 x 25.0. (Cube: 12 ft <sup>3</sup> )		
Weight (lbs)	285	285	
Engine	4 cylinder gasoline, 6 hp @ 3600 RPM, rope start, air cooled.		
Fuels	Automotive gasoline, (emergency - aviation gasoline);		
Fuel Capacity	3.6 gal		
Performance Characteristics			
Electric Power Rating	3kW (AC @0.8 pf) from -25°F (-65°F with Winterization kit) to: 125°F/MSL, 107°F/5000 ft, 95°F/8000 ft.		
Instrumentation	Voltmeter, frequency meter, ammeter, hourmeter.		
Environmental Capability	rain, humidity, altitude, sand/dust, 3 foot drop, transportation, vibration, -65°F cold storage, salt spray, fungus. Operable at incline to 15%.		
Protective Devices	Short circuit.		
Fuel Consumption	0.84 gal/hour @ rated load..		
Human Factors	MIL-STD-1474. Man portable.		
Noise	79 dBA @ 25 ft.		
Reliability( MTBF)	250 hr specified.		
Electrical Characteristics			
Connection	120/208V, 3ph, 4 wire	120/240V, 1ph, 3 wire	28 VDC, 2 wire
Voltage Adj Range	197 - 218 V	228 -252 V	26.6 - 29.4
Frequency Adj Range	-3%		
Electrical	Drip proof generator enclosure, fungus & moisture treated, solid state voltage regulator, brushless rotary exciter.		
Electrical Performance			
Electric Power Quality	AC Voltage	Frequency	DC Voltage
Short term steady state stability (30 sec)	2% bandwidth	1% bandwidth	
Long term steady state stability (4 hr)	2% bandwidth	2% bandwidth	2% bandwidth
Application/Rejection of rated load recovery time	30%dip/rise, 2 sec	3%dip/ 5% rise, 4 sec/ 6 sec	30%dip/40%rise, 2 sec
Max waveform deviation factor	6%-1ph; 5%-3ph		
Individual waveform harmonic	3%		
Ripple			5.5%
Regulation	4% (5% @ 240V)	3%	4%
EMI	Suppressed to MIL-STD-461 limits.		
EMP	HAEMP protected.		
Optional Equipment			
Description	NSN	Weight (lbs)	Effect on Dim.(in)
Spark arrester kit	2990-01-032-7384		none
Canvas cover (wint kit)	6115-00-941-1655	5	negligible
Torch (wint kit)	4520-00-710-4341		negligible
Diesel conversion kit*	2815-01-440-4426	negligible	none
* Avail. to US Army Reserves.			

MIL-HDBK-633A  
APPENDIX E

Technical Manuals			
Army	Air Force	Marine Corps	Navy
TM5-6115-271-14	TO35C2-3-386-1		
TM5-6115-271-15	TO35C2-3-386-4	SL-4-06926A	
TM5-2805-203-14	TO38G2-90-1		
TM5-2805-203-24P	TO38G2-90-14	SL-4-03522B	P-8-613E-24P
LO5-2805-203-12			



MEP-026C (typical DC)

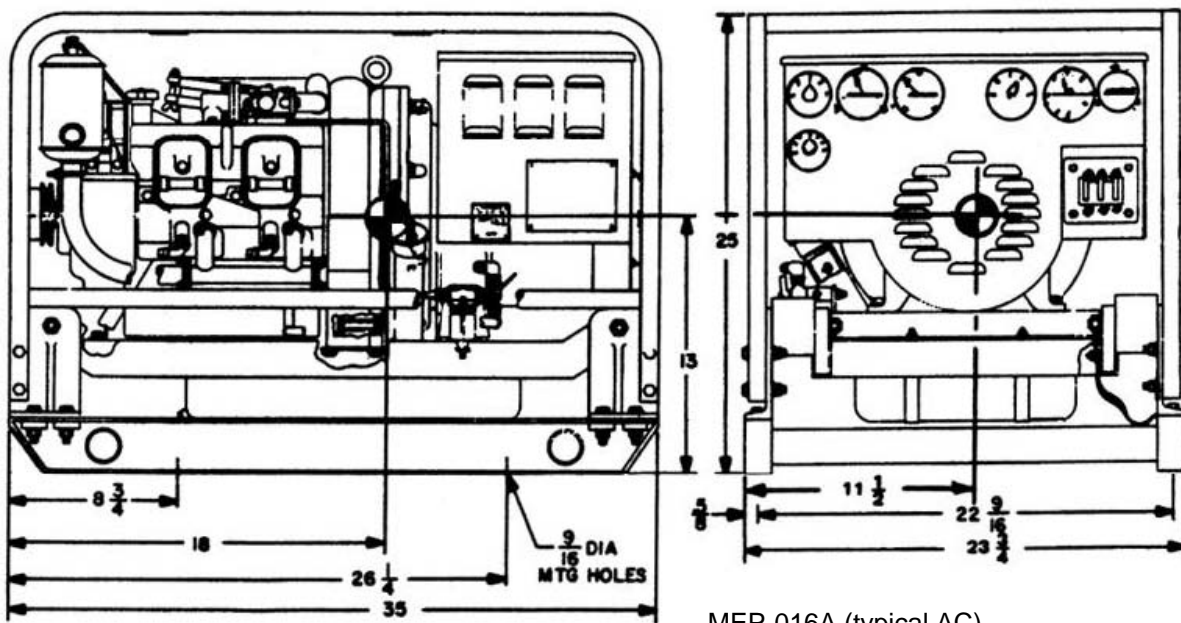

MEP-016A (typical AC)

Figure E-3 3 kW, GED, Generator Set

**MIL-HDBK-633A  
APPENDIX E**

**3 kW, DED, 60 Hz Generator Set**

Identification Data			
Nomenclature	Gen Set, DED, 3kW, 60 Hz		w/Acoustic Suppression Kit (ASK)
Model Number	MEP-016B		MEP-701A
NSN	6115-01-150-4140		6115-01-234-5966
LIN	G54041		G54041
SSN			
Trailer mounted configurations			PP-AN/MJQ-32, <a href="#">Figure E- 5</a> PP-AN/MJQ-33, <a href="#">Figure E- 6</a>
Configuration	Tubular frame skid or housed in ASK. Lifting & tie down.		
Physical Characteristics			
Dimension LWH (in)	35.0 x 23.8 x 25.0 (Cube 12 ft <sup>3</sup> )		44.0 x 28.5 x 30.0 (Cube:20 ft <sup>3</sup> )
Weight (lbs)	Dry 468	Wet: 526	Dry: 532      Wet: 590
Engine	Diesel, 8 horsepower @ 3600 RPM, 24 Volt starter, air cooled, mechanical governor, auxiliary fuel pump.		
Fuels	Diesel: DL-1, DL-2 and Jet fuel: JP-8, Jet A-1.		
Instrumentation	Hourmeter, voltmeter, frequency meter, load meter.		
Performance Characteristics			
Electric Power Rating	3 kW @ 0.8 pf from -25°F to 125°F/MSL, 107°F/ 5000 ft, 95°F/8000 ft.		
Environmental Capability	-25°F to 125°F, rain, humidity, altitude, sand/dust, transportation, -65°F cold storage, salt spray, fungus.		
Protective Devices	Automatic shut down with emergency bypass for low fuel, low oil, overspeed, and overload.		
Fuel Consumption	37 gal/hour @ rated load. Fuel capacity: 4.5 gal.		
Human Factors	MIL-STD-1474. Operable in arctic and NBC clothing.		
Noise	75 dBA @ 7 meters (23 ft)w/ Acoustic Suppression Kit (ASK).		
Reliability (MTBF)	350 hr (specified).		
Electrical Characteristics			
Connection	120/208V, 3 ph, 4 wire	120/240V, 1 ph, 3 wire	120V, 1 ph, 2 wire, convenience recept
Voltage Adj Range	197 - 218 V	228 -252 V	114 - 126 V
Frequency Adj Range		-3%	
Electrical	Drip proof generator enclosure, fungus & moisture treated, solid state voltage regulator, brushless rotary alternator.		
Electrical Performance			
Electric Power Quality	Voltage		Frequency
Short term steady state stability (30 sec)	2% bandwidth		1% bandwidth
Long term steady state stability (4 hr)	2% bandwidth		2% bandwidth
Application/rejection of rated load, recovery time	30% dip, 2 sec		3% / 5% , 4 sec/ 6 sec
Max waveform deviation factor	6% (1 ph); 5% (3 ph)		
Individual waveform harmonic	3% (1 & 3 ph)		
Regulation	4% (5% @ 240V)		3%
Optional Equipment			
Description	NSN	Weight (lbs)	Effect on Dim.(in)
Acoustic suppression kit	6115-01-271-1584	64	L+8, W+4, H+3
Diesel upgrade kit* <small>* Available to USMC.</small>	1730-01-418-0970	negligible	none
EMI	Suppressed to MIL-STD-461 limits.		
EMP	Not protected.		
Technical Manuals			
Army	Air Force	Marine Corps	Navy
TM5-6115-615-12	TO35C2-3-386-31	TM 05926B/06509B-12	NAVFAC P-8-646-12
TM5-6115-615-34	TO35C2-3-386-32	TM 05926B/06509B-34/3	NAVFAC P-8-646-34
TM5-6115-615-24P	TO35C2-3-386-34	SL-4-05926B/06509B-24P/2	NAVFAC P-8-646-24P



MIL-HDBK-633A  
APPENDIX E

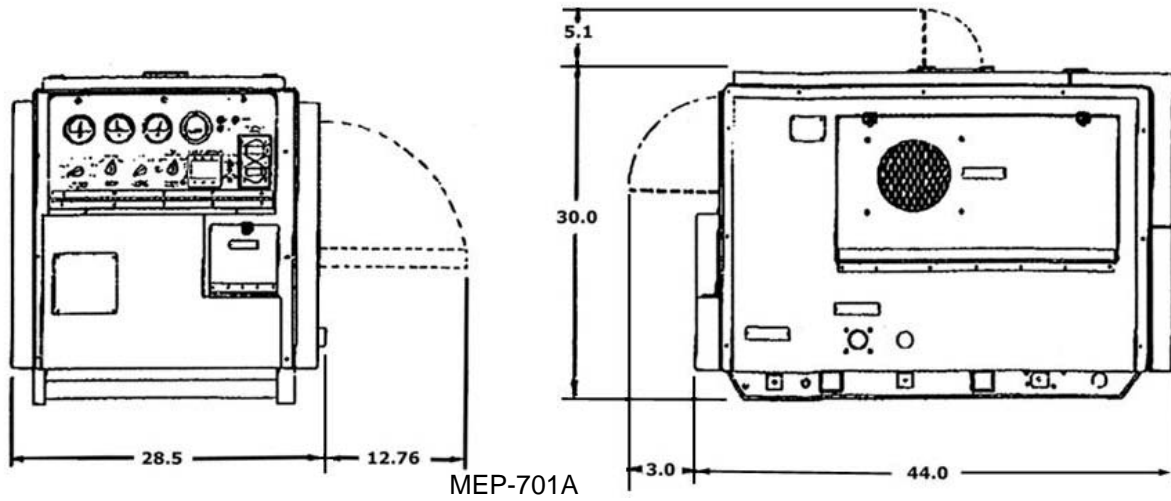

Figure E- 4 3 kW, DED, 60 Hz Generator Set

**MIL-HDBK-633A  
APPENDIX E**

**PP-AN/MJQ-32, POWER PLANT, DED, 3kW, 60 Hz, TRLMTD**

Replaced by PP-AN/MJQ-42

Identification Data					
Description	POWER PLANT, DED, 3kW, 60 Hz, TRLMTD			Camouflage: 97403-13226E7478	
<b>Model</b>	<b>NSN</b>	<b>LIN</b>	<b>SSN</b>	<b>ASSEMBLY</b>	<b>SPEC</b>
PP-AN/MJQ-32	6115-01-280-2300	Z75718	M548	TA-13228E9895	Not procurable
Physical Characteristics					
<b>Dimensions LWH (in) &amp; (Cube) (ft<sup>3</sup>)</b>	<b>Ship Cube (ft<sup>3</sup>)</b>		<b>Wet Weight (lbs)</b>	<b>Ship Weight (lbs)</b>	
147.5 x 73.3 x 68.1	450		3160	2720	

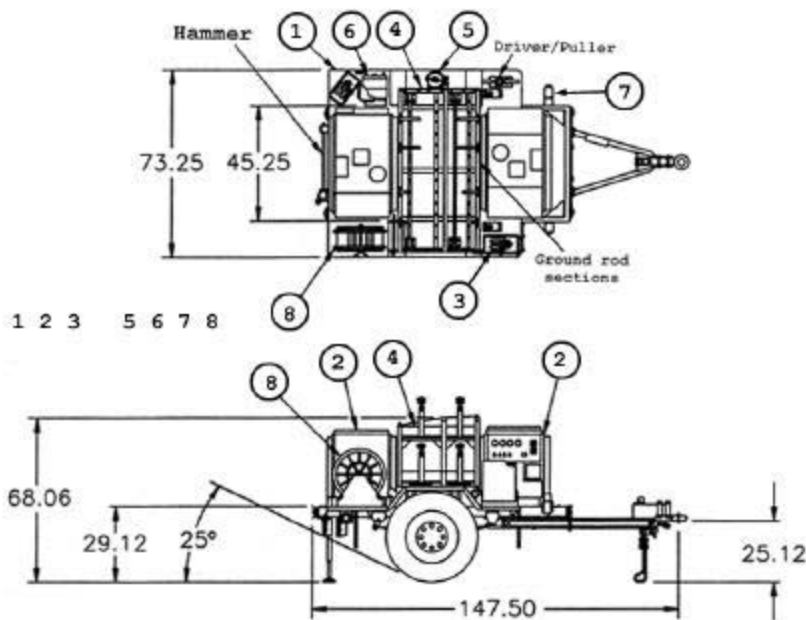

COMPONENT	QTY	FIND	IDENTIFIER
3/4 Ton modified Trailer, M116A2	1	1	97403-13228E9896
Generator set, DED, 3 kW, 60 Hz, MEP-701A	2	2	6115-01-234-5966
Fuel can, 5 gallon	2	3	
Stowage rack assembly	1	4	97403-13228E9902
Fire extinguisher, 5 lb., A-A-1106	1	5	4210-00-270-4512
Switch box, 97403-13205E5079-3 (old)	1	6	97403-13229E5765
Support masts	1 ea.	7	97403-13228E9872
Cable reel, RC-435/4	1	8	MIL-R-55566

Figure E- 5 PP-AN/MJQ-32

**MIL-HDBK-633A  
APPENDIX E**

**PP-AN/MJQ-33, POWER PLANT, DED, 3kW, 60 Hz, TRLMTD**

Replaced by PP-AN/MJQ-43

Identification Data					
Description	POWER PLANT, DED, 3kW, 60 Hz, TRLMTD			Camouflage: 97403-13226E7478	
<b>Model</b>	<b>NSN</b>	<b>LIN</b>	<b>SSN</b>	<b>ASSEMBLY</b>	<b>SPEC</b>
PP-AN/MJQ-33	6115-01-280-2301	Z13577	M506	TA-13229E2300	Not procurable
Physical Characteristics					
<b>Dimensions LWH (in) &amp; (Cube) (ft<sup>3</sup>)</b>	<b>Ship Cube(ft<sup>3</sup>)</b>		<b>Wet Weight (lbs)</b>	<b>Ship Weight (lbs)</b>	
145.3 x 73.5 x 73.9	390		2840	2850	

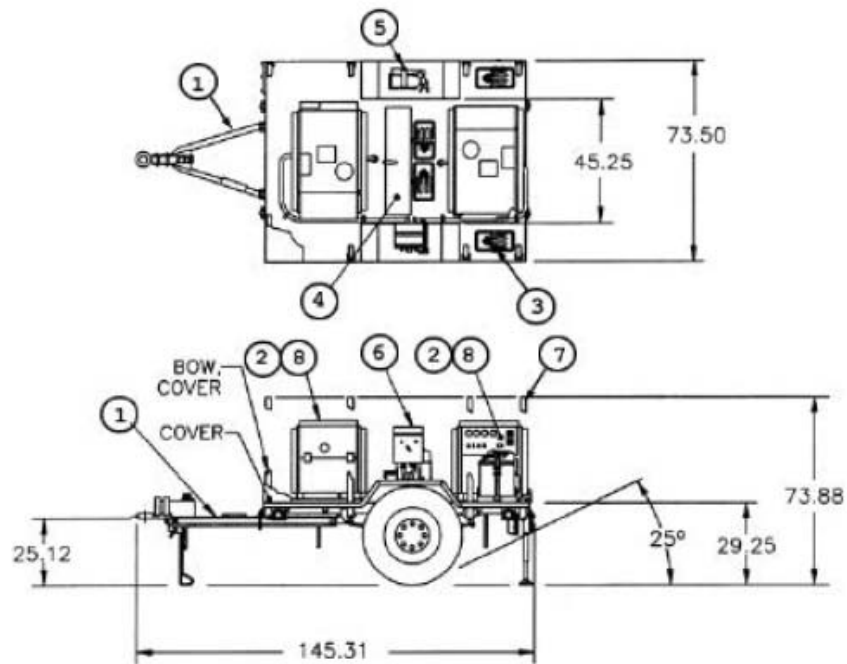

COMPONENT	QTY	FIND	IDENTIFIER
3/4 Ton modified Trailer, M116A2	1	1	97403-13228E9896
Generator set, DED, 3 kW, 60 Hz, MEP-701A	2	2	6115-01-234-5966
Fuel can, 5 gallon	2	3	
Accessory box	1	4	97403-13226E7737
Fire extinguisher, 5 lb., A-A-1106	1	5	4210-00-270-4512
Switch box, 97403-13205E5079-4 (old)	1	6	97403-13229E5765
Support masts	1 ea.	7	97403-13228E9872
Acoustic Suppression Kit	2	8	incl w/MEP-701A

Figure E- 6 PP-AN/MJQ-33

**MIL-HDBK-633A  
APPENDIX E**

**5 kW, GED, Generator Set**

<b>Identification Data</b>			
Nomenclature	5 kW, 60 Hz, GED, TU	5 kW, 400 Hz, GED, TU	
Model Number	MEP-017A	MEP-022A	
NSN	6115-00-017-8240	6115-00-017-8241	
LIN	J47068	J48713	
Configuration	Tubular frame skid, lifting attachments provided.		
<b>Physical Characteristics</b>			
Dimensions LWH (in)	39.8 x 30.0 x 25.0 (Cube: 17 ft <sup>3</sup> )		
Weight (lbs)	488	479	
Engine	2 cylinder gasoline, 10 hp @ 3600(60 Hz)&3428(400 Hz) RPM, rope and 24 VDC start, air cooled.		
Fuels	Automotive gasoline, (emergency - aviation gasoline);		
Fuel Capacity	5.0 gal.		
Instrumentation	Voltmeter, frequency meter, ammeter, hourmeter, oil pressure gage, battery charging ammeter.		
<b>Performance Characteristics</b>			
Electric Power Rating	5 kW @ 0.8 pf from -25°F (-65°F with Winterization kit) to 125°F/MSL, 107°F/5000 ft, 95°F/8000 ft.		
Environmental Capability	Rain, humidity, altitude, sand/dust, transportation, 3 foot drop, vibration, cold storage, salt spray, fungus. Operable at incline to 15°.		
Protective Devices	Short circuit, low oil pressure.		
Fuel Consumption	1.4 gal/hour @ rated load.		
Human Factors	MIL-STD-1474. Man portable.		
Noise	82 dBA @ 25 ft.		
Reliability (MTBF)	250 hr (specified).		
<b>Electrical Characteristics</b>			
Connection	120/208V, 3ph, 4 wire	120/240V, 1ph, 3 wire	120V, 1ph, 2 wire
Voltage Adj Range	197 - 218 V	228 -252 V	114 - 126 V
Frequency Adj Range	-3%		
Electrical	Drip proof generator enclosure, fungus & moisture treated, solid state voltage regulator, brushless rotary exciter.		
EMI	Suppressed to MIL-STD-461 limits.		
EMP	HAEMP protected.		
<b>Electrical Characteristics</b>			
<b>Electric Power Quality</b>	<b>AC Voltage</b>		<b>Frequency</b>
Short term steady state stability (30 sec)	2% bandwidth		1% bandwidth
Long term steady state stability (4 hr)	2% bandwidth		2% bandwidth
Application/rejection of rated load, recovery time	30% dip/rise, 2 sec		3% under/ 5% over, 4 sec/ 6 sec
Max waveform deviation factor	6%-1ph; 5%-3ph		
Individual waveform harmonic	3%		
Regulation	4% (5% @ 240V)		3%
<b>Optional Equipment</b>			
<b>Description</b>	<b>NSN</b>	<b>Weight (lbs)</b>	<b>Effect on Dim.(in)</b>
Spark arrester kit	2990-01-032-0757		none
Canvas cover (wint kit)	6115-00-945-7545	5	negligible
Torch (wint kit)	4520-00-710-4341		negligible
<b>Technical Manuals</b>			
<b>Army</b>	<b>Air Force</b>	<b>Marine Corps</b>	<b>Navy</b>
TM5-6115-332-14	TO35C2-3-424-1		P-8-614-14
TM5-6115-332-24P	TO35C2-3-424-24		
TM5-2805-258-14	TO38G2-89-21	TM-03523B-14	
TM5-2805-258-24P	TO38G2-89-34	SL-4-035-32B	

MIL-HDBK-633A  
APPENDIX E

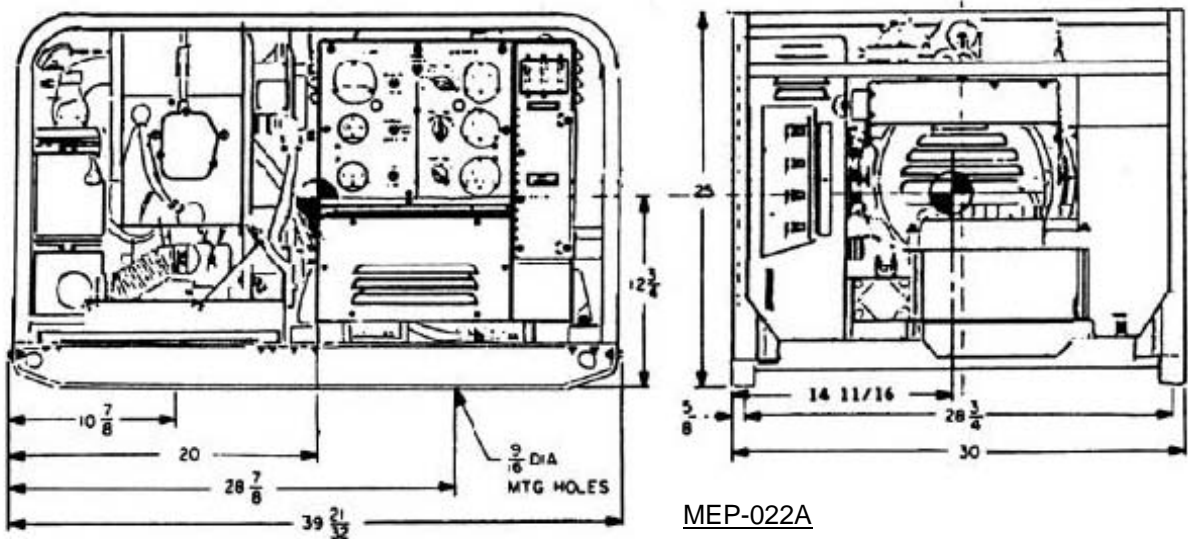

Figure E- 7 5 kW, GED, Generator Set

**MIL-HDBK-633A  
APPENDIX E**

**5 kW, DED, 60 Hz Generator Set**

<b>Identification Data</b>			
Nomenclature	Gen Set, DED, 5 kW, 60 Hz		
Model Number	MEP-002A		
NSN	6115-01-465-1044		
LIN	J35813		
SSN	M535		
Trailer mounted configuration	PU-751/M, <a href="#">Figure E- 9</a> , PU-797, <a href="#">Figure E- 10</a> PP-AN/MJQ-16, <a href="#">Figure E- 11</a> , PP-AM/MJQ-35, <a href="#">Figure E- 12</a>		
Configuration	Skid mounted, fork lift guides provided.		
<b>Physical Characteristics</b>			
Dimensions LWH (in)	50.6 x 32.0 x 37.0 (Cube: 35 ft <sup>3</sup> )		
Weight (lbs)	930		
Engine	2 cylinder Diesel, 9.0 horsepower @ 1800 RPM, 24 Volt starter.		
Fuels	Diesel: DL-1, DL-2 and Jet fuel: JP-8, Jet A-1.		
Fuel Capacity	6.75 gal.		
<b>Performance Characteristics</b>			
Electric Power Rating	5 kW @ 0.8 pf from -25°F (-65°F w/ wint kit) to 125°F/MSL, 107°F/ 5000 ft; 4.5 kW to 95°F/8000 ft.		
Environmental Capability	-25°F to 125°F, rain, humidity, altitude, sand/ dust, transportation, cold storage, salt spray, fungus.		
Human Factors	MIL-STD-1474. Operable in arctic and NBC clothing.		
Noise	79 dBA @ 25 feet.		
Protective Devices	Overload, short circuit, low oil pressure, high temp.		
Fuel Consumption	0.57 gal/hour @ rated load		
Reliability (MTBF)	500 hr (specified).		
Instrumentation	Hourmeter, voltmeter, frequency meter, ammeter, oil pressure gage, battery charging ammeter.		
<b>Electrical Characteristics</b>			
Connection	120/208V, 3 ph, 4 wire	120/240V, 1 ph, 3 wire	120V, 1 ph, 2 wire
Volt Adj Range	205 V - 220 V	228 V - 252 V	114 V - 126 V
Frequency Adj Range	-3%		
Electrical Drip proof generator enclosure, fungus & moisture treated, solid state voltage regulator, brushless rotary alternator.			
<b>Electrical Performance</b>			
<b>Electric Power Quality</b>	<b>Voltage</b>	<b>Frequency</b>	
Short term steady state stability (30 sec)	2% bandwidth	2% bandwidth	
Long term steady state stability (4 hr)	4% bandwidth	3% bandwidth	
Application/Rejection of rated load, recovery time	20% dip/20% rise, 3 sec	3% und/4% over, 3 sec	
Max waveform deviation factor	6% (1 ph); 5% (3 ph)		
Individual waveform harmonic	3%		
Motor load	35% dip, 5 sec recovery		
Regulation	3%	3%	
EMI	Suppressed to MIL-STD-461 limits.		
EMP	Not protected		
<b>Optional Equipment</b>			
<b>Description</b>	<b>NSN</b>	<b>Weight (lbs)</b>	<b>Effect on Dim.(in)</b>
Aux fuel burning wint kit		350 max	41 x 40 x 26
<b>Technical Manuals</b>			
<b>Army</b>	<b>Air Force</b>	<b>Marine Corps</b>	<b>Navy</b>
TM5-6115-548-12	TO35C2-3-456-1	TM 05682C-12	NAVFAC P-8-622-12
TM5-6115-548-34	TO35C2-3-456-2	TM 05682C-34	NAVFAC P-8-622-34
TM5-6115-548-24P	TO35C2-3-456-4	SL-4-05682C	NAVFAC P-8-622-24P
LO5-6115-584-12			

MIL-HDBK-633A  
APPENDIX E



MEP-002A

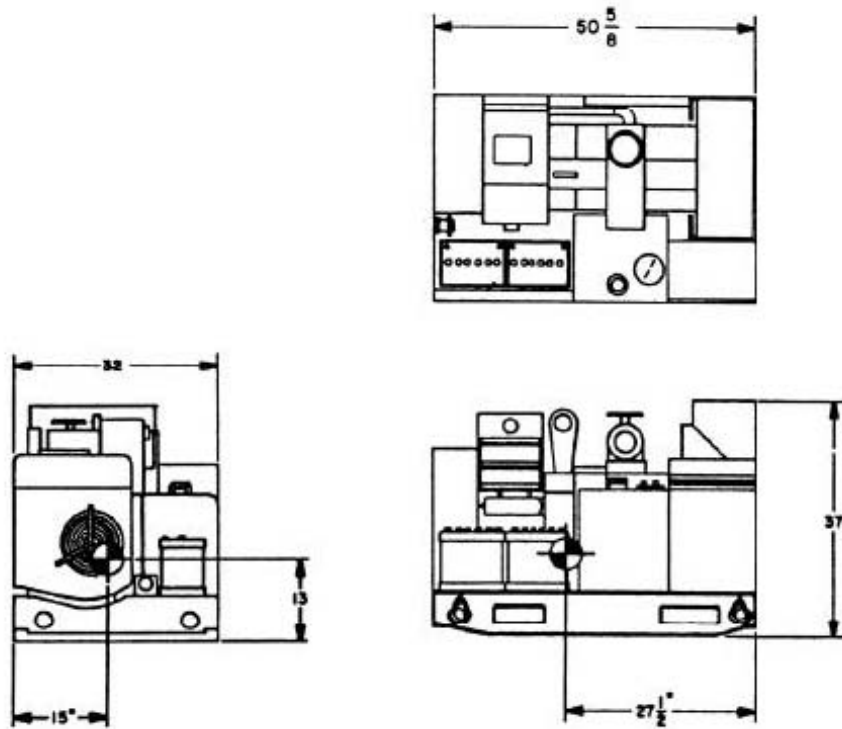
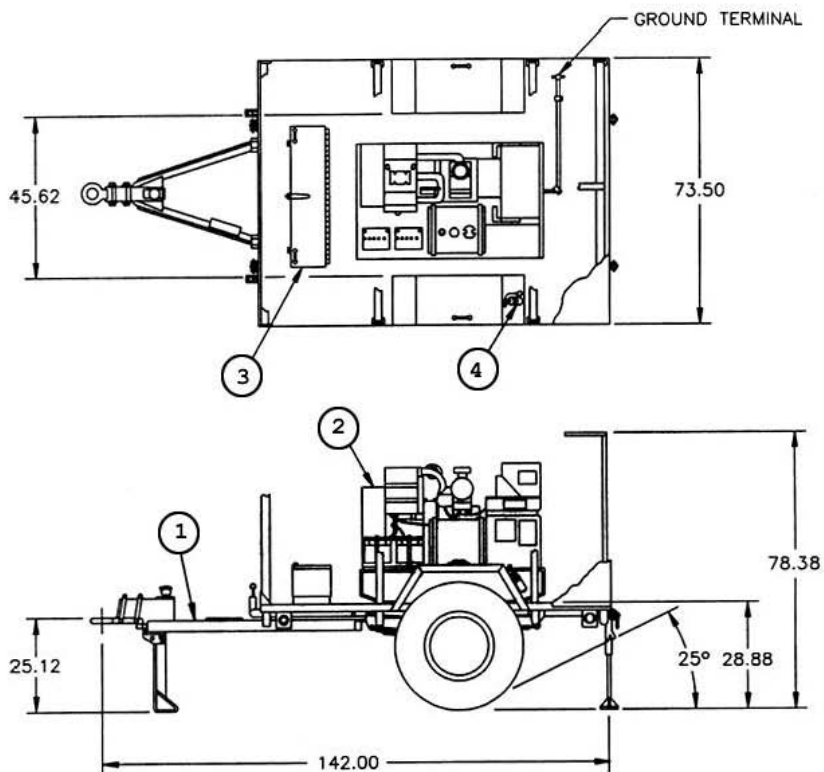

Figure E- 8 5 kW, DED, 60 Hz Generator Set

MIL-HDBK-633A  
APPENDIX E

PU-751/M, POWER UNIT, DED, 5 kW, 60 Hz, TRLMTD

Identification Data					
Description	POWER UNIT, DED, 5 kW, 60 Hz, TRLMTD			Camouflage: 97403-13226E7510	
<b>Model</b>	<b>NSN</b>	<b>LIN</b>	<b>SSN</b>	<b>ASSEMBLY</b>	<b>SPEC</b>
PU-751/M	6115-00-033-1373	G37273	M565	TA-13221E7323	Not procurable
Physical Characteristics					
<b>Dimensions LWH (in) &amp; (Cube) (ft<sup>3</sup>)</b>	<b>Ship Cube (ft<sup>3</sup>)</b>		<b>Wet Weight (lbs)</b>	<b>Ship Weight (lbs)</b>	
142.0 x 73.5 x 78.4	412		2644	2720	



COMPONENT	QTY	FIND	IDENTIFIER
3/4 Ton modified Trailer, M116A2	1	1	97403-13221E7325
Generator set, DED, 5 kW, 60 Hz, MEP-002A	1	2	6115-01-465-1044
Accessory box	1	3	97403-13226E7737
Fire extinguisher, 5 lb., A-A-1106	1	4	4210-00-270-4512

Figure E- 9 PU-751/M



**MIL-HDBK-633A  
APPENDIX E**

**5 kW TQ Power Unit, 60 Hz, TRLMTD**

Identification Data					
Description	TQ POWER UNIT, 5 kW, 60 Hz, TRLMTD			Camouflage: 97403-13228E1608	
<b>Model</b>	<b>NSN</b>	<b>LIN</b>	<b>SSN</b>	<b>ASSEMBLY</b>	<b>SPEC</b>
PU-797	6115-01-332-0741	G42238	R62700	TA-13229E5705	not procurable
Technical Manual	Operator, Unit and Direct Support			TM 9-6115-659-13&P	
Physical Characteristics					
<b>Dimensions LWH (in) &amp; (Cube) (ft<sup>3</sup>)</b>	<b>Ship Cube (ft<sup>3</sup>)</b>		<b>Wet Weight (lbs)</b>	<b>Ship Weight (lbs)</b>	
145 x 84 x 76 & (535)	535		2320	2360	

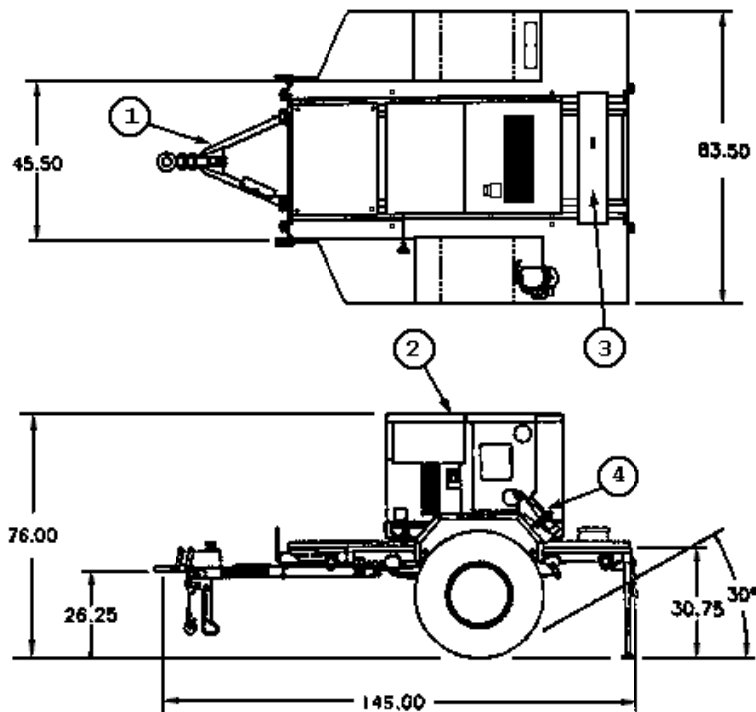

FIND	COMPONENT	QTY	IDENTIFIER
1	Modified 1 ton trailer, M116A3	1	97403-13229E5757
2	TQ Generator set, DED, 5 kW, 60 Hz, MEP-802A	1	6115-01-274-7387
3	Accessory box	1	97403-13229E7946
4	Fire extinguisher, 5 lb., A-A-1106	1	4210-00-270-4512

Figure E- 10 PU-797

**MIL-HDBK-633A  
APPENDIX E**

**PP-AN/MJQ-16, POWER PLANT, DED, 5 kW, 60 Hz, TRLMTD**

Identification Data					
Description	POWER PLANT, DED, 5 kW, 60 Hz, TRLMTD			Camouflage: 97403-13226E7506	
<b>Model</b>	<b>NSN</b>	<b>LIN</b>	<b>SSN</b>	<b>ASSEMBLY</b>	<b>SPEC</b>
PP-AN/MJQ-16	6115-01-033-1395	P41832	M538	TA-13220E4455	Not procurable
Physical Characteristics					
<b>Dimensions LWH (in) &amp; (Cube) (ft<sup>3</sup>)</b>		<b>Ship Cube (ft<sup>3</sup>)</b>		<b>Wet Weight (lbs)</b>	<b>Ship Weight (lbs)</b>
171.1 x 83.0 x 98.0		614		5308	5160

COMPONENT	QTY	FIND	IDENTIFIER
1-1/2 ton flatbed trailer, M103A3/A4	1	1	97403-13226E5858
Generator set, DED, 5 kW, 60 Hz, MEP-002A	2	2	6115-01-465-1044
Accessory box	1	3	97403-13226E7737
Fire extinguisher, 5 lb., A-A-1106	2	4	4210-00-270-4512
Switch box, 97403-13212E3601 (old)	1	5	97403-13229E6535

Figure E- 11 PP-AN/MJQ-16

**MIL-HDBK-633A  
APPENDIX E**

**5 kW TQ Power Plant, 60 Hz, TRLMTD**

Identification Data					
Description	TQ POWER PLANT, 5 kW, 60 Hz, TRLMTD			Camouflage: 97403-13228E1609	
<b>Model</b>	<b>NSN</b>	<b>LIN</b>	<b>SSN</b>	<b>ASSEMBLY</b>	<b>SPEC</b>
PP-AN/MJQ-35	6115-01-313-4216	P28083	R62700	TA-13229E5650	not procurable
Technical Manual	Operator, Unit and Direct Support			TM 9-6115-659-13&P	
Physical Characteristics					
<b>Dimensions (LWH (in)) &amp; (Cube) (ft<sup>3</sup>)</b>	<b>Ship Cube (ft<sup>3</sup>)</b>		<b>Wet Weight (lbs)</b>	<b>Ship Weight (lbs)</b>	
154 x 84 x 74 & (553)	553		3183	3100	

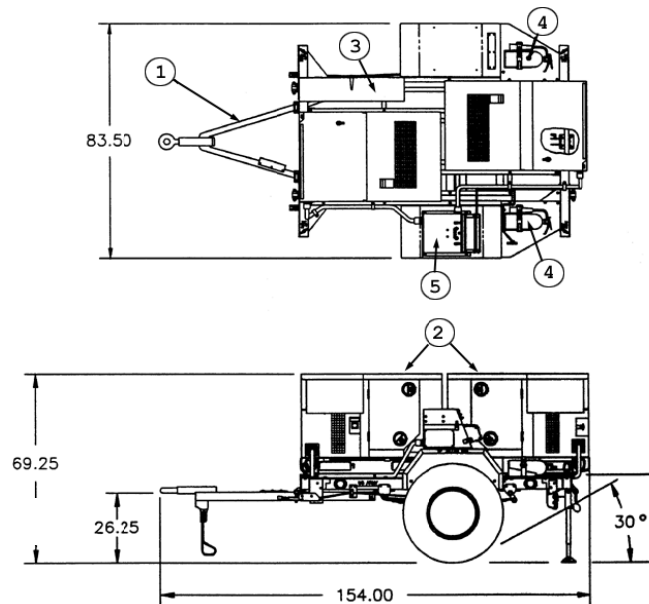

FIND	COMPONENT	QTY	IDENTIFIER
1	Modified 1 ton trailer, M116A3	1	97403-13229E5757
2	Generator set, DED, 5 kW, 60 Hz, MEP-802A	2	6115-01-274-7387
3	Accessory box	1	97403-13229E7946
4	Fire extinguisher, 5 lb., A-A-1106	1	4210-00-270-4512
5	Switch box	1	97403-13230E6535

Figure E- 12 PP-AN/MJQ-35

**MIL-HDBK-633A  
APPENDIX E**

**10 kW, DED, Generator Set**

<b>Identification Data</b>			
Nomenclature	Gen Set, DED, 10kW, 60 Hz		Gen Set, DED, 10kW, 400 Hz
Model Number	MEP-003A		MEP-112A
NSN	6115-00-465-1030		6115-01-465-1027
LIN	J35825		G35981
SSN	M529		M565
Trailer mounted configurations	PU-753M, Figure E- 14, PU-798, Figure E- 15 PP-AN/MJQ-18, Figure E- 17		PU-799, Figure E- 16 PP-AN/MJQ-25, Figure E- 18
<b>Physical Characteristics</b>			
Dimensions LWH (in)	50.6 x 32.0 x 37.0 (Cube: 35 ft <sup>3</sup> )		50.6 x 32.0 x 37.0 (Cube: 35 ft <sup>3</sup> )
Weight (lbs):	1240		1325
Engine	4 cylinder Diesel, 20 hp @ 1800/2000 RPM, air cooled, 24 Volt starter.		
Fuels Diesel:	DL-1, DL-2 and Jet fuel: JP-8, Jet A-1.		
Fuel Capacity	12.5 gal.		
Instrumentation	Hourmeter, voltmeter, frequency meter, ammeter, oil pressure gage, battery charging ammeter.		
<b>Performance Characteristics</b>			
Electric Power Rating	10 kW @ 0.8 pf from -25°F (-65°F with winterization kit) to 125°F/MSL, 107°F/ 5000 ft, 9 kW to 95°F/8000 ft.		
Environmental Capability	-25°F(-65°F w/wint kit) to 125°F, rain, humidity, altitude, sand/dust, transportation, cold storage, salt spray, fungus. Noise 77 dBA @ 25 feet.		
Protective Devices	Overload, short circuit, low oil pressure, high temp.		
Fuel Consumption	1.09 gal/hour @ rated load.		
Human Factors	MIL-STD-1474. Operable in arctic and NBC clothing		
Reliability (MTBF)	500 hr (specified).		
<b>Electrical Characteristics</b>			
Connection	120/208V, 3 ph, 4 wire	240V, 1 ph, 3 wire	120V, 1 ph, 2 wire
Voltage Adj Range	205 V to 220 V	228 V to 252 V	114 V to 126 V
Frequency Adj Range	-3% - 60 Hz; -4% - 400 Hz		
Electrical	Drip proof generator enclosure, fungus & moisture treated, solid state voltage regulator, brushless rotary alternator.		
EMI	Suppressed to MIL-STD-461 limits.		
EMP	none		
<b>Electrical Performance</b>			
<b>Electric Power Quality</b>	<b>Voltage</b>	<b>Frequency</b>	
Short term steady state stability (30 sec)	2% bandwidth	2% bandwidth	
Long term steady state stability (4 hr)	4% bandwidth	3% bandwidth	
Application/rejection of rated load, recovery time	20% dip/rise, 3 sec	3% under/4% over, 3 sec	
Max waveform deviation factor	6% (1 ph); 5% (3 ph)		
Individual waveform harmonic	3% (1 ph); 2% (3 ph)		
Motor load	35% dip, 5 sec recovery		
Regulation	3%		3%
<b>Optional Equipment</b>			
<b>Description</b>	<b>NSN</b>	<b>Weight (lbs)</b>	<b>Effect on Dim.(in)</b>
Aux fuel burning wint kit		350 max	41 x 40 x 26
<b>Technical Manuals</b>			
<b>Army</b>	<b>Air Force</b>	<b>Marine Corps</b>	<b>Navy</b>
TM5-6115-585-12	TO35C2-3-455-1	TM 05684C-12	NAVFAC P-8-623-12
TM5-6115-585-34	TO35C2-3-455-2	TM 05684C-34	NAVFAC P-8-623-34
TM5-6115-585-24P	TO35C2-3-455-4	SL-4-05684C	NAVFAC P-8-623-24P

MIL-HDBK-633A  
APPENDIX E



MEP-003A or MEP-112A

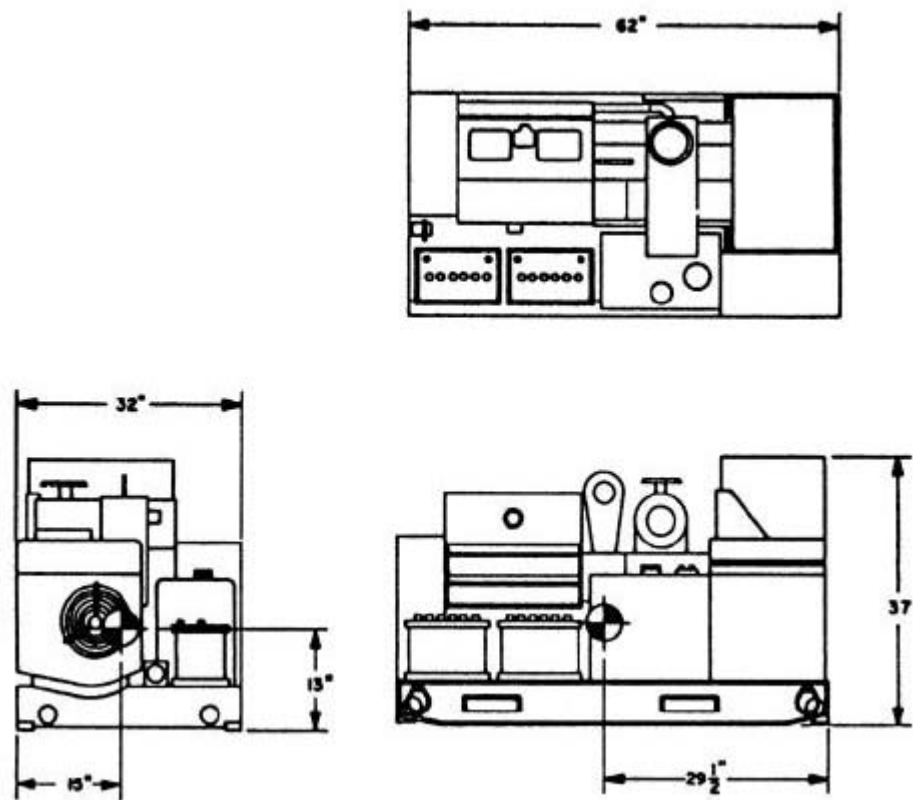
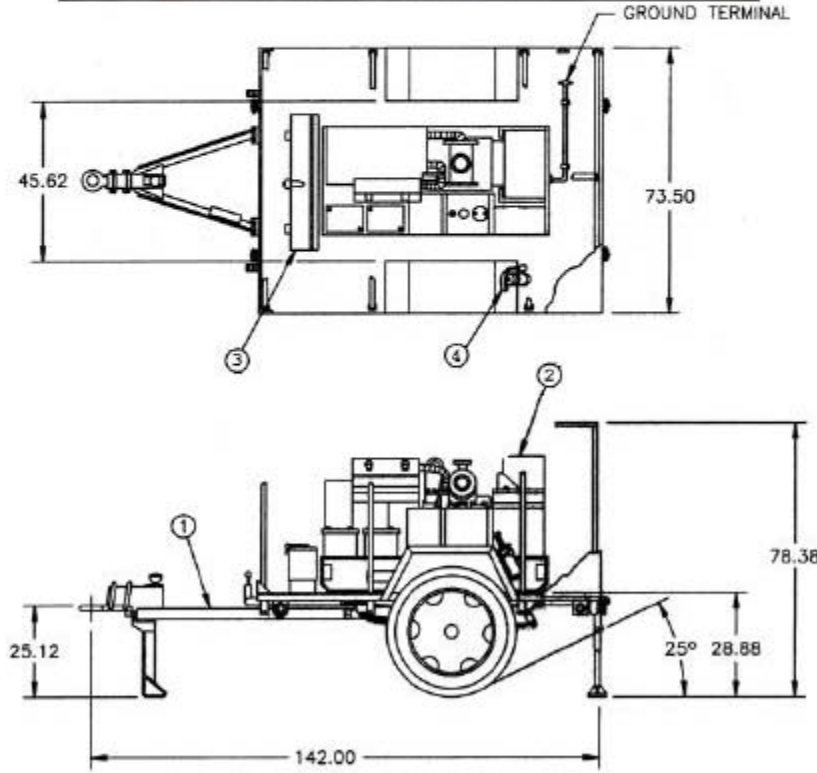

Figure E- 13 10 kW, DED, Generator Set

MIL-HDBK-633A  
APPENDIX E

PU-753/M, POWER UNIT, DED, 10kW, 60 Hz, TRLMTD

Identification Data					
Description	POWER UNIT, DED, 10kW, 60 Hz, TRLMTD			Camouflage: 97403-13226E7508	
<b>Model</b>	<b>NSN</b>	<b>LIN</b>	<b>SSN</b>	<b>ASSEMBLY</b>	<b>SPEC</b>
PU-753/M	6115-00-033-1389	G40744	M567	TA-13221E7330	Not procurable
Physical Characteristics					
<b>Dimensions LWH (in) &amp; (Cube) (ft<sup>3</sup>)</b>	<b>Ship Cube (ft<sup>3</sup>)</b>		<b>Wet Weight (lbs)</b>	<b>Ship Weight (lbs)</b>	
142.0 x 73.5 x 78.4	412		3040	3060	



COMPONENT	QTY	find	IDENTIFIER
3/4 Ton modified Trailer, M116A2	1	1	97403-13221E7325
Generator set, DED, 10 kW, 60 Hz, MEP-003A	1	2	6115-00-465-1030
Accessory box	1	3	97403-13226E7737
Fire extinguisher, 5 lb., A-A-1106	2	4	4210-00-270-4512

Figure E- 14 PU-753/M

**MIL-HDBK-633A  
APPENDIX E**

**10 kW TQ Power Unit, 60 Hz, TRLMTD**

Identification Data					
Description	10 kW TQ POWER UNIT, 60 Hz, TRLMTD			Camouflage: 97403-13228E1611	
<b>Model</b>	<b>NSN</b>	<b>LIN</b>	<b>SSN</b>	<b>ASSMEBLY</b>	<b>SPEC</b>
PU-798	6115-01-319-9032	G42170	R62700	TA-13229E5715	not procurable
Technical Manual	Operator, Unit and Direct Support			TM 9-6115-660-13&P	
Physical Characteristics					
<b>Dimensions LWH (in) &amp; (Cube) (ft<sup>3</sup>)</b>	<b>Ship Cube (ft<sup>3</sup>)</b>		<b>Wet Weight (lbs)</b>	<b>Ship Weight (lbs)</b>	
145 x 84 x 76 & (535)	535		2454	2380	



PU-798

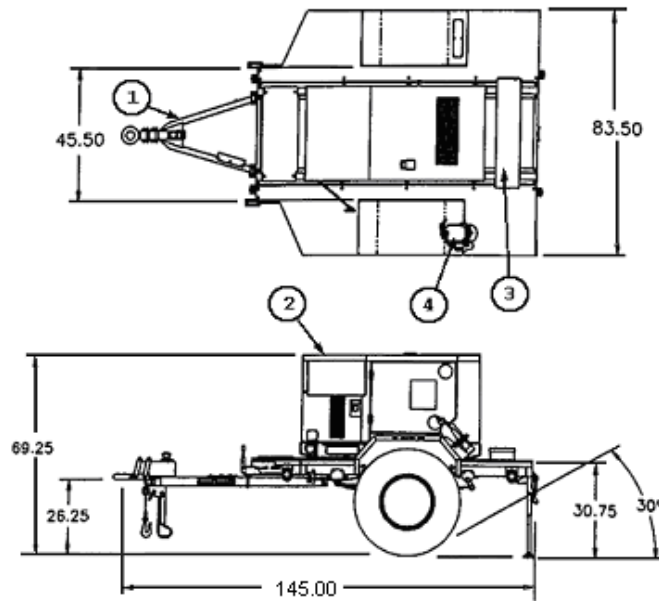

(Change "145.00" to "147.00")

FIND	COMPONENT	QTY	IDENTIFIER
1	1 Ton modified Trailer, M116A3 (shown)	1	97403-13229E5757
2	Generator set, TQ DED, 10 kW, 60 Hz, MEP-803A	1	6115-01-275-5061
3	Accessory box	1	97403-13229E7946
4	Fire extinguisher, 5 lb., A-A-1106	1	4210-00-270-4512

Figure E- 15 PU-798

**MIL-HDBK-633A  
APPENDIX E**

**10 kW TQ Power Unit, 400 Hz, TRLMTD**

Identification Data					
Description	10 kW TQ POWER UNIT, 400 Hz, TRLMTD			Camouflage: 97403-13228E1611	
<b>Model</b>	<b>NSN</b>	<b>LIN</b>	<b>SSN</b>	<b>ASSEMBLY</b>	<b>SPEC</b>
PU-799	6115-01-313-4283	G53403	R62700	TA-13229E5725	not procurable
Technical Manual	Operator, Unit and Direct Support			TM 9-6115-660-13&P	
Physical Characteristics					
<b>Dimensions LWH (in) &amp; (Cube) (ft<sup>3</sup>)</b>	<b>Ship Cube (ft<sup>3</sup>)</b>		<b>Wet Weight (lbs)</b>	<b>Ship Weight (lbs)</b>	
145 x 84 x 76 & (535)	535		2485	2410	

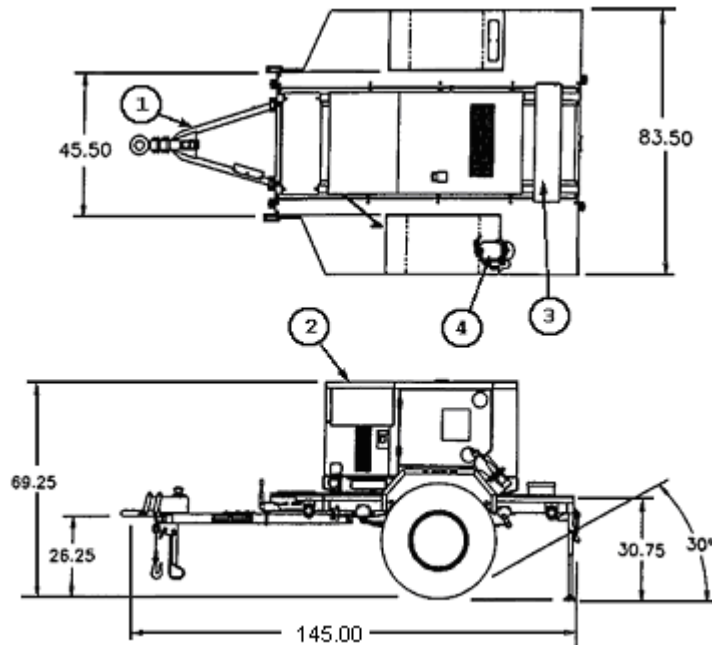

FIND	COMPONENT	QTY	IDENTIFIER
1	Modified 1 ton trailer, M116A3	1	97403-13229E5757
2	TQ Generator set, DED, 10 kW, 400 Hz, MEP-813A	1	6115-01-274-7392
3	Accessory box	1	97403-13229E7946
4	Fire extinguisher, 5 lb., A-A-1106	1	4210-00-270-4512

Figure E- 16 PU-799



MIL-HDBK-633A  
APPENDIX E

PP-AN/MJQ-18, POWER PLANT, DED, 10kW, 60 Hz, TRLMTD

Identification Data					
Description	POWER PLANT, DED, 10kW, 60 Hz, TRLMTD			Camouflage: 97403-13226E7504	
<b>Model</b>	<b>NSN</b>	<b>LIN</b>	<b>SSN</b>	<b>ASSEMBLY</b>	<b>SPEC</b>
PP-AN/MJQ-18	6115-00-033-1398	P28015	M540	TA-13220E4465	Not procurable
Physical Characteristics					
<b>Dimensions LWH (in) &amp; (Cube) (ft<sup>3</sup>)</b>		<b>Ship Cube (ft<sup>3</sup>)</b>	<b>Wet Weight (lbs)</b>	<b>Ship Weight (lbs)</b>	
171.1 x 83.0 x 98.0		614	5930	5900	

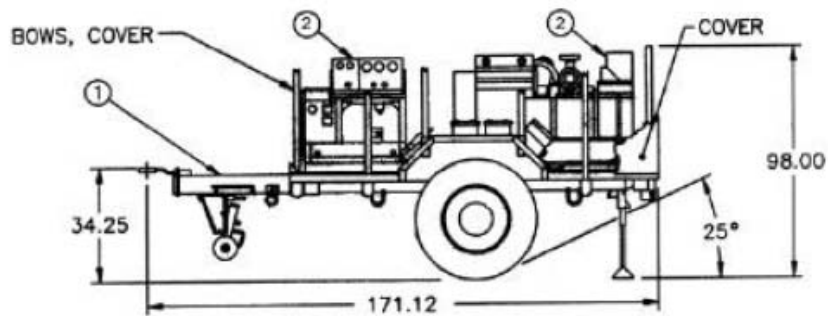
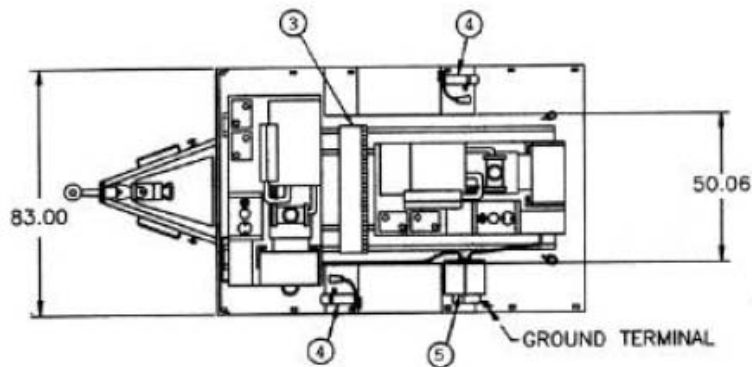

COMPONENT	QTY	FIND	IDENTIFIER
1-1/2 ton flatbed trailer, M103A3/A4	1	1	97403-13226E5858
Generator set, DED, 10 kW, 60 Hz, MEP-003A	2	2	6115-00-465-1030
Accessory box	1	3	97403-13226E7737
Fire extinguisher, 5 lb., A-A-1106	2	4	4210-00-270-4512
Switch box, 97403-13226E5859 (old)	1	5	97403-13229E6535

Figure E- 17 PP-AN/MJQ-18

MIL-HDBK-633A  
APPENDIX E

PP-AN/MJQ-25, POWER PLANT, DED, 10kW, 400 Hz, TRLMTD

Identification Data					
Description	POWER PLANT, DED, 10kW, 400 Hz, TRLMTD			Camouflage: 97403-13226E7512	
<b>Model</b>	<b>NSN</b>	<b>LIN</b>	<b>SSN</b>	<b>ASSEMBLY</b>	<b>SPEC</b>
PP-AN/MJQ-25	6115-01-153-7742	P42364	M523	TA-13226E5860	Not procurable
Physical Characteristics					
<b>Dimensions LWH (in) &amp; (Cube) (ft<sup>3</sup>)</b>		<b>Ship Cube (ft<sup>3</sup>)</b>		<b>Wet Weight (lbs)</b>	<b>Ship Weight (lbs)</b>
171.1 x 83.0 x 98.0		614		5980	5960

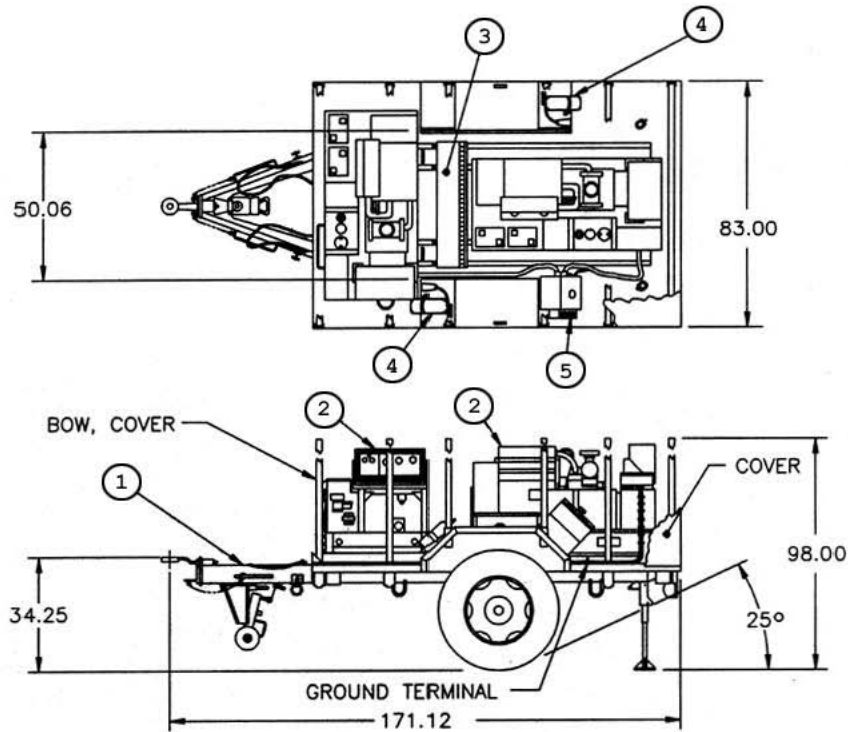

COMPONENT	QTY	FIND	IDENTIFIER
1-1/2 ton flatbed trailer, M103A3/A4	1	1	97403-13226E5858
Generator set, DED, 10 kW, 400 Hz, MEP-112A	2	2	6115-01-465-1027
Accessory box	1	3	97403-13226E7737
Fire extinguisher, 5 lb., A-A-1106	2	4	4210-00-270-4512
Switch box	1	5	97403-13226E5859

Figure E- 18 PP-AN/MJQ-25

**MIL-HDBK-633A  
APPENDIX E**

**10 kW, GED, Generator Set**

<b>Identification Data</b>			
Nomenclature	10 kW, 60 Hz, GED, TU	10 kW, 400 Hz, GED, TU	
Model Number	MEP-018A	MEP-023A	
NSN	6115-00-889-1447	6115-00-926-0843	
LIN	J49398	J49466	
Configuration	Tubular frame skid, lifting attachments provided.		
<b>Physical Characteristics</b>			
Dimensions LWH (in)	57.0 x 30.0 x 28.4 (Cube: 28 ft <sup>3</sup> )	51.0 x 30.0 x 27.0 (Cube: 24 ft <sup>3</sup> )	
Weight (lbs)	850	650	
Engine	4 cylinder gasoline, 20 hp @ 3600(60 Hz) & 3428(400 Hz) RPM, rope and 24 VDC start, air cooled.		
Fuels	Automotive gasoline, emergency - aviation gasoline		
Fuel Capacity.	5.0 gal		
Instrumentation	Voltmeter, frequency meter, ammeter, hourmeter, oil pressure gage, battery charging ammeter.		
<b>Performance Characteristics</b>			
Electric Power Rating	10 kW @ 0.8 pf from -25°F (-65°F with winterization kit) to 125°F/MSL, 107°F/ 5000 ft, 95°F/8000 ft.		
Environmental Capability	Rain, humidity, altitude, sand/dust, transportation, 3 foot drop, vibration, cold storage: -45°F, salt spray, fungus. Operable at incline to 15%.		
Protective Devices	Short circuit, low oil pressure.		
Fuel Consumption	2.4 gal/hour @ rated load.		
Human Factors.	MIL-STD-1474		
Noise	82 dBA @ 25 ft.		
Reliability (MTBF)	250 hr (specified)		
<b>Electrical Characteristics</b>			
Connection	120/208V, 3ph, 4 wire	120/240V, 1ph, 3 wire	120V, 1ph, 2 wire
Voltage Adj Range	197 V - 218 V	228 V - 252 V	114 V - 126 V
Electrical	Drip proof generator enclosure, fungus & moisture treated, solid state voltage regulator, brushless rotary exciter.		
EMI	Suppressed to MIL-STD-461 limits.		
EMP	None.		
<b>Electrical Performance</b>			
<b>Electric Power Quality</b>	<b>AC Voltage</b>		<b>Frequency</b>
Short term steady state stability (30 sec)	1% bandwidth		1% bandwidth
Long term steady state stability (4 hr)	1% bandwidth		2% bandwidth
Application/rejection of rated load, recovery time	20% dip/rise, 2 sec		3% under/5% over, 4 sec/6 sec
Motor load; recovery time	40% dip; 4 sec		
Max waveform deviation factor	6%-1ph; 5%-3ph		
Individual waveform harmonic	2%		
Regulation	3%; 4% - 240V 3 wire		3%
<b>Optional Equipment</b>			
<b>Description</b>	<b>NSN</b>	<b>Weight (lbs)</b>	<b>Effect on Dim.(in)</b>
Spark arrester kit	2990-01-032-3750		none
Canvas cover (wint kit)	6115-00-066-4933	10	negligible
Torch (winterization kit)	4520-00-710-4341		negligible
<b>Technical Manuals</b>			
<b>Army</b>	<b>Air Force</b>	<b>Marine Corps</b>	<b>Navy</b>
TM5-6115-275-14	TO35C2-3-452-1		P-8-615-14
TM5-6115-275-24P	TO35C2-3-452-24		P-8-615-24P
TM5-2805-259-14	TO38G2-89-41	TM-03524B-14	
TM5-2805-259-24P	TO38G2-89-54	SL-4-035-24B	

MIL-HDBK-633A  
APPENDIX E



MEP-018A

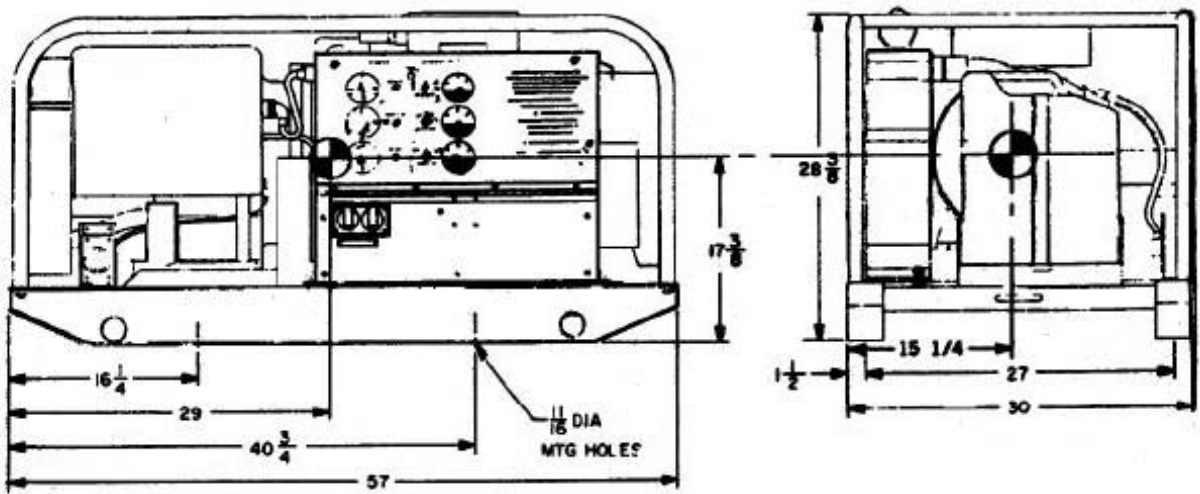

Figure E- 19 10 kW, GED, Generator Set

**MIL-HDBK-633A  
APPENDIX E**

**15 kW DED Generator set**

Identification Data						
Nomenclature	Gen Set, DED, 15 kW, 50/60 Hz			Gen Set, DED, 15 kW, 400 Hz		
Model Number	MEP-004A			MEP-113A		
NSN	6115-00-118-1241			6115-00-118-1244		
LIN	J35835			J36006		
SSN	M549			M526		
Trailer mounted configurations	PU-405A/M; Figure E-21; PU-801, <a href="#">Figure E- 24</a> ; PU-801A, <a href="#">Figure E- 25</a> ; PU-802; <a href="#">Figure E- 26</a> ; AN/MJQ-48, <a href="#">Figure E- 29</a> ; AN/MJQ-48A, <a href="#">Figure E- 30</a>			PU-732/M; Figure E-22; PU-800, <a href="#">Figure E- 23</a> ; AN/MJQ-15; <a href="#">Figure E- 27</a> ; AN/MJQ-39, <a href="#">Figure E- 28</a>		
Physical Characteristics						
Dimension LWH (in)	69.8 x 35.8 x 54.6 (Cube: 75 ft <sup>3</sup> )			69.8 x 35.8 x 54.6 (Cube: 75 ft <sup>3</sup> )		
Weight (lbs)	2450			2500		
Engine	4 cylinder Diesel, 41 hp @ 1500/1800 RPM (50/60 Hz), liquid cooled, 24 Volt starter.			4 cylinder Diesel, 45 hp @ 2000 RPM (400 Hz) liquid cooled, 24 Volt starter		
Fuels Diesel:	DL-1, DL-2 and Jet fuel: JP-8, Jet A-1.					
Fuel Capacity	15 gal.					
Instrumentation	Hourmeter, voltmeter, frequency meter, ammeter, wattmeter, oil pressure, battery charge, fault indicating system, water temp, fuel.					
Performance Characteristics						
Electric Power Rating	15kW, 60Hz (12.5kW, 50Hz) @ 0.8 pf from -25°F (-65°F w/wint kit) to 125°F/MSL; 107°F/ 5000 ft.					
Environmental Capability	-25°F to 125°F, rain, humidity, altitude, sand/dust, transportation, -65°F cold storage, salt spray, fungus.					
Protective Devices	Overload, over voltage, short circuit, reverse power, low oil pressure, high temp., low fuel, overspeed.					
Fuel Consumption	1.5 gal/hour @ rated load					
Human Factors	MIL-STD-1474.					
Noise	80 dBA @ 25 feet.					
Reliability (MTBF)	670 hr (50/60 Hz),			370 hr (400 Hz) (specified).		
Electrical Characteristics						
Connection	120/208V, 3 phase, 4 wire			240/416V, 3 phase, 4 wire		
Frequency	50 Hz	60 Hz	400 Hz	50 Hz	60 Hz	400 Hz
Voltage Adj Range	190 - 213	380 - 426	197 - 240	395 - 480	197 - 229	395 - 458
Frequency Adj Range	-50%	390-420 Hz	-50%	390-420 Hz		
Electrical	Drip proof generator enclosure, fungus & moisture treated, solid state voltage regulator, brushless rotary alternator.					
EMI.	Suppressed to MIL-STD-461 limits					
EMP.	Not protected					
Electrical Performance						
Electric Power Quality	50/60 Hz			400 Hz		
	Volt	Frequency		Volt	Frequency	
Short term steady state stability (30 sec)	2% bandwth	2% bandwth		1% bandwth	0.5% bw	
Long term steady state stability (4 hr)	4% bandwth	3% bandwth		2% bandwth	1% bandwth	
Applic./reject.of rated load/recovery	20% /3 sec	3%/4% /3 sec		12% /0.5 sec	1.5% /1 sec	
Max waveform deviation factor	5%			5%		
Individual waveform harmonic	2%			2%		
Motor load	40% dip			25% dip		
Recovery	5 sec			0.7 sec		
Regulation	3%	2-3% (adj)		1%	0.25%	
Optional Equipment						
Description	NSN	Weight (lbs)		Effect on Dim.(in)		
Fuel burning winterization kit	6115-00-463-9083	45		Internal		
Electrical winterization kit	6115-00-463-9085	40		internal		
Aux fuel burning wint kit	6115-00-463-9098	350		41 x 40 x 26 (Aux)		
Aux electrical winterization kit	6115-00-463-9099	260		36 x 27 x 19 (Aux)		
Remote control box	6115-00-420-8490	8		internal		
Load bank	6115-00-291-9201	104		L+9		
Wheel mounting kit	6115-00-463-9094	564		L+8, W+32, H+9		
Auto load tranf panel 60 Hz	6115-00-471-7932	825		44 x 19 x 42 (Aux)		
Paralleling cable	6140-00-197-4934	4		negligible		
Precise relay assembly	6115-00-368-8202			internal		
Spark arrester kit	2990-01-032-0756	7.5		L+12		

**MIL-HDBK-633A  
APPENDIX E**

Technical Manuals:			
Army	Air Force	Marine Corps	Navy
TM5-6115-464-12	TO35C2-3-445-1	TM 07523A-12	NAVFAC P-8-624-12
TM5-6115-464-34	TO35C2-3-445-2	TM 07523A-34	NAVFAC P-8-624-34
TM5-6115-464-24P	TO35C2-3-445-4	SL-4-07523A	NAVFAC P-8-624-24P
LO-5-6115-464-12			



MEP-004A or MEP-113A

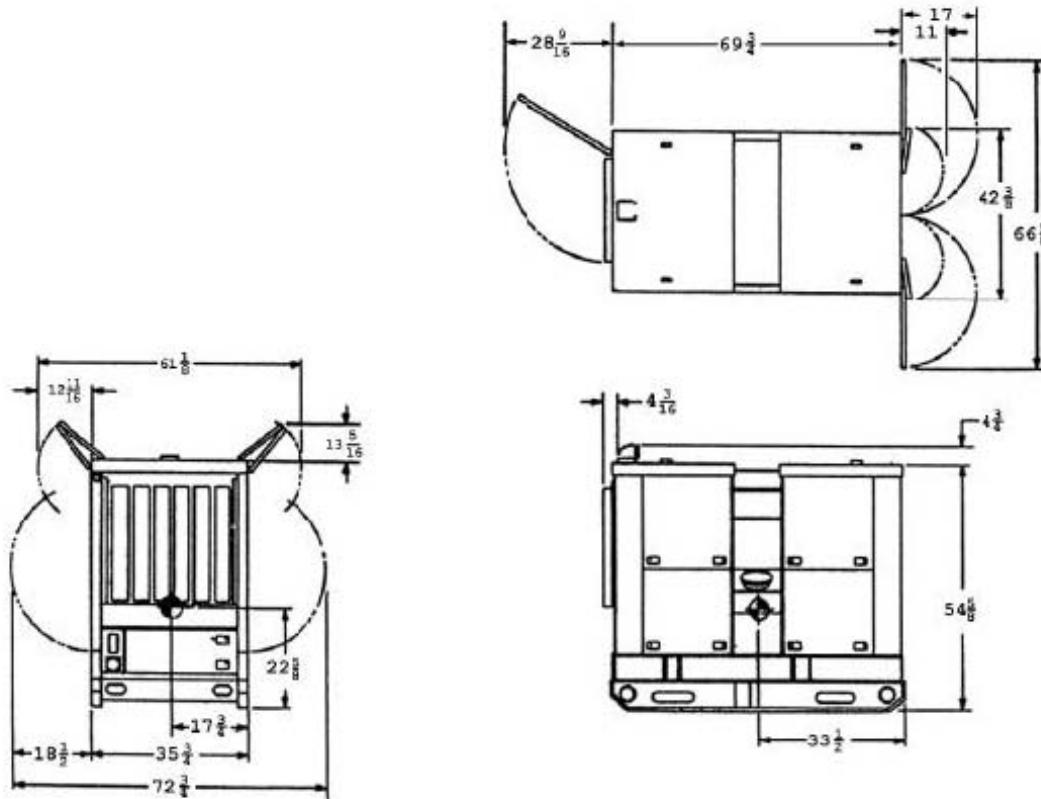
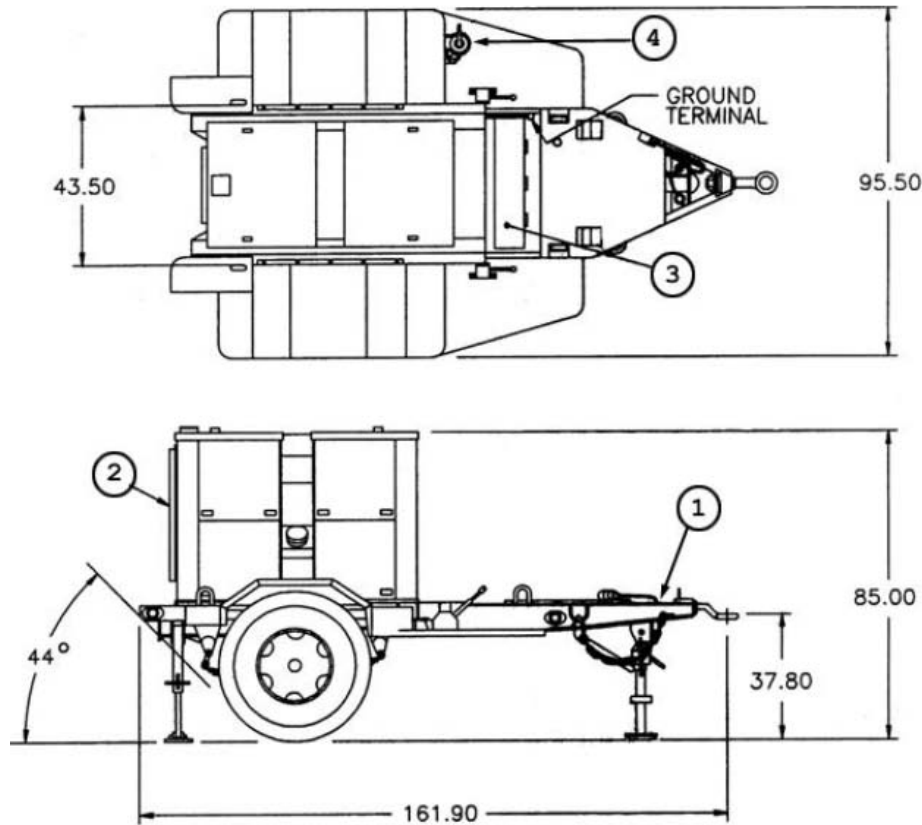

Figure E- 20 15 kW, DED, Generator Set -

MIL-HDBK-633A  
APPENDIX E

PU-405A/M, POWER UNIT, DED, 15 kW, 50/60 Hz, TRLMTD

Identification Data					
Description	POWER UNIT, DED, 15 kW, 50/60 Hz, TRLMTD			Camouflage: 97403-13226E7154	
<b>Model</b>	<b>NSN</b>	<b>LIN</b>	<b>SSN</b>	<b>ASSEMBLY</b>	<b>SPEC</b>
PU-405A/M	6115-00-394-9577	J35492	M500	TA-13220E6322	Not procurable
Physical Characteristics					
<b>Dimensions LWH (in) &amp; (Cube) (ft<sup>3</sup>)</b>		<b>Ship Cube (ft<sup>3</sup>)</b>		<b>Wet Weight (lbs)</b>	<b>Ship Weight (lbs)</b>
161.9x 95.5 x 85.0		800		5970	5860



COMPONENT	QTY	FIND	IDENTIFIER
2-1/2 Ton modified Trailer, M200A1	1	1	97403-13214E1257
Generator set, DED, 15 kW, 60 Hz, MEP-004A	1	2	6115-00-118-1241
Accessory box	1	3	97403-13226E7737
Fire extinguisher, 5 lb, A-A-1106	1	4	4210-00-270-4512

Figure E- 21 PU-405A/M

**MIL-HDBK-633A  
APPENDIX E**

**PU-732/M, POWER UNIT, DED, 15 kW, 400 Hz, TRLMTD**

Identification Data					
Description	POWER UNIT, DED, 15 kW, 400 Hz, TRLMTD			Camouflage: 97403-13226E7154	
<b>Model</b>	<b>NSN</b>	<b>LIN</b>	<b>SSN</b>	<b>ASSEMBLY</b>	<b>SPEC</b>
PU-732/M	6115-00-260-3082	G36074	M521	TA-13220E6645	Not procurable
Physical Characteristics					
<b>Dimensions LWH (in) &amp; (Cube) (ft<sup>3</sup>)</b>	<b>Ship Cube (ft<sup>3</sup>)</b>		<b>Wet Weight (lbs)</b>	<b>Ship Weight (lbs)</b>	
161.9 x 95.5 x 85.0	800		6080	5900	

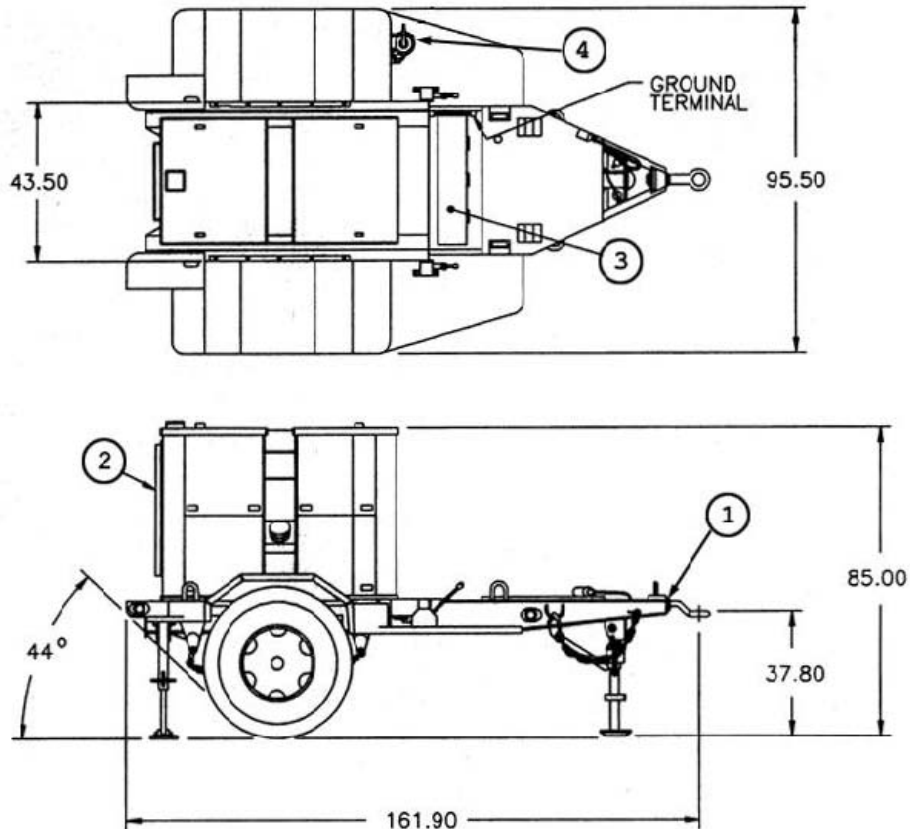

COMPONENT	QTY	FIND	IDENTIFIER
2-1/2 Ton modified Trailer, M200A1	1	1	97403-13214E1257
Generator set, DED, 15 kW, 400 Hz, MEP-113A	1	2	6115-00-118-1244
Accessory box	1	3	97403-13226E7737
Fire extinguisher, 5 lb., A-A-1106	1	4	4210-00-270-4512

Figure E- 22 PU-732/M



**MIL-HDBK-633A  
APPENDIX E**

**15 kW TQ Power Unit, 400 Hz, TRLMTD**

Identification Data					
Description	15 kW TQ POWER UNIT, 400 Hz, TRLMTD			Camouflage: 97403-13228E1614	
<b>Model</b>	<b>NSN</b>	<b>LIN</b>	<b>SSN</b>	<b>ASSEMBLY</b>	<b>SPEC</b>
PU-800	6115-01-317-2137	G78203	R62700	TA-13229E5735	not procurable
Technical Manual	Operator, Unit and Direct Support			TM 9-6115-661-13&P	
Physical Characteristics					
<b>Dimensions LWH (in) &amp; (Cube) (ft<sup>3</sup>)</b>	<b>Ship Cube (ft<sup>3</sup>)</b>		<b>Wet Weight (lbs)</b>	<b>Ship Weight (lbs)</b>	
165 x 95 x 84 & (761)	761		4975	4855	

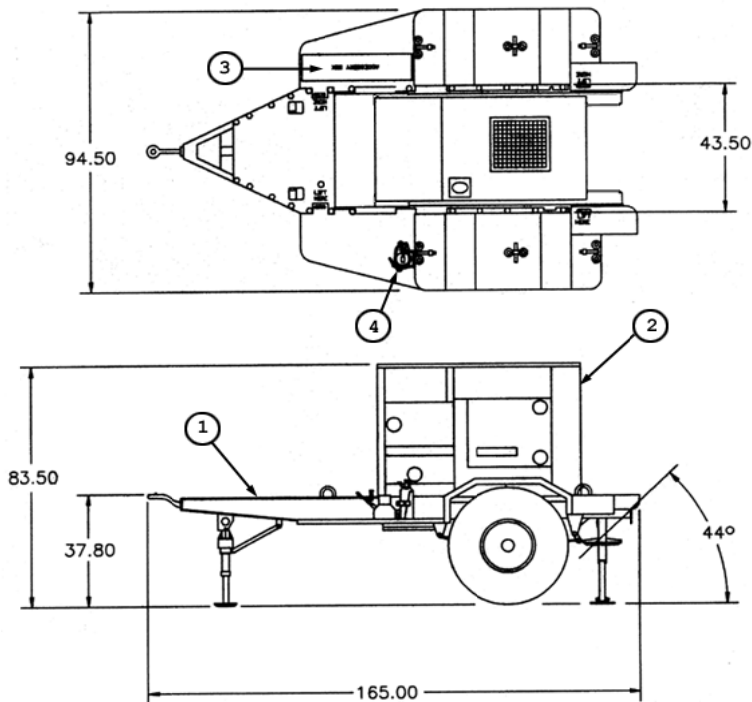

FIND	COMPONENT	QTY	IDENTIFIER
1	2 1/2 Ton modified Trailer, M200A1	1	97403-13229E9623
2	TQ Generator set, DED, 15 kW, 400 Hz, MEP-814A	1	6115-01-274-7393
3	Accessory box	1	97403-13229E7946
4	Fire extinguisher, 5 lb., A-A-1106	1	4210-00-270-4512

Figure E- 23 PU-800

**MIL-HDBK-633A  
APPENDIX E**

**15 kW TQ Power Unit, 50/60 Hz, TRLMTD**

Identification Data					
Description	15 kW TQ POWER UNIT, 50/60 Hz, TRLMTD			Camouflage: 97403-13228E1613	
<b>Model</b>	<b>NSN</b>	<b>LIN</b>	<b>SSN</b>	<b>ASSEMBLY</b>	<b>SPEC</b>
PU-801	6115-01-319-9033	G78374	R62700	TA-13229E5640	not procurable
Technical Manual	Operator, Unit and Direct Support			TM 9-6115-661-13&P	
Physical Characteristics					
<b>Dimensions LWH (in) &amp; (Cube) (ft<sup>3</sup>)</b>	<b>Ship Cube (ft<sup>3</sup>)</b>		<b>Wet Weight (lbs)</b>	<b>Ship Weight (lbs)</b>	
145 x 85 x 86 & (613)	613		3416	3300	

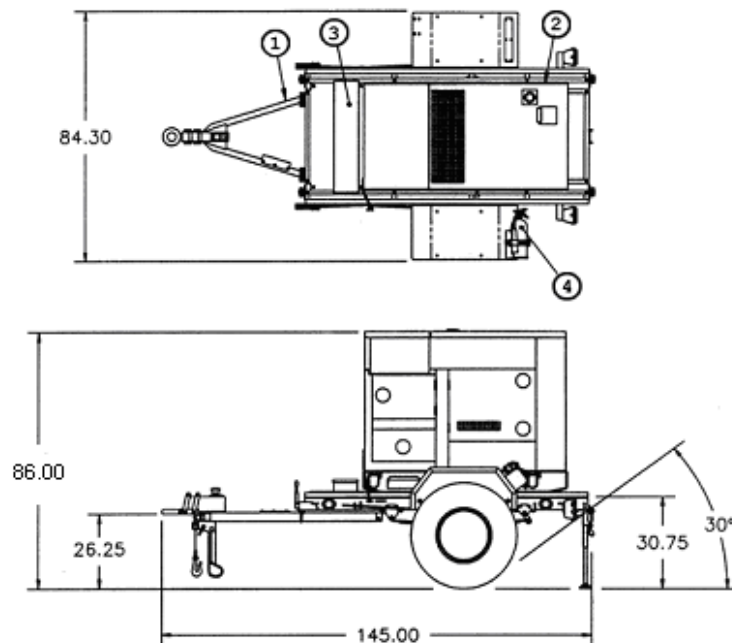

FIND	COMPONENT	QTY	IDENTIFIER
1	Modified 1 ton trailer, M116A3	1	97403-13229E5757
2	TQG set, DED, 15 kW, 50/60 Hz, MEP-804A	1	6115-01-274-7388
3	Accessory box	1	97403-13229E7946
4	Fire extinguisher, 5 lb., A-A-1106	1	4210-00-270-4512

Figure E- 24 PU-801

**MIL-HDBK-633A  
APPENDIX E**

**15 kW TQ Power Unit, 50/60 Hz, TRLMTD**

Identification Data					
Description	15 kW TQ POWER UNIT, 50/60 Hz, TRLMTD			Camouflage: 97403-13228E1613	
<b>Model</b>	<b>NSN</b>	<b>LIN</b>	<b>SSN</b>	<b>ASSEMBLY</b>	<b>SPEC</b>
PU-801A	6115-01-413-3821	G78374	R62700	TA-13230E6560	not procurable
Technical Manual	Operator, Unit and Direct Support			TM 9-6115-661-13&P	
Physical Characteristics					
<b>Dimensions LWH (in) &amp; (Cube) (ft<sup>3</sup>)</b>	<b>Ship Cube (ft<sup>3</sup>)</b>		<b>Wet Weight (lbs)</b>	<b>Ship Weight (lbs)</b>	
135 x 86 x 91 & (611)	611		3516	3400	

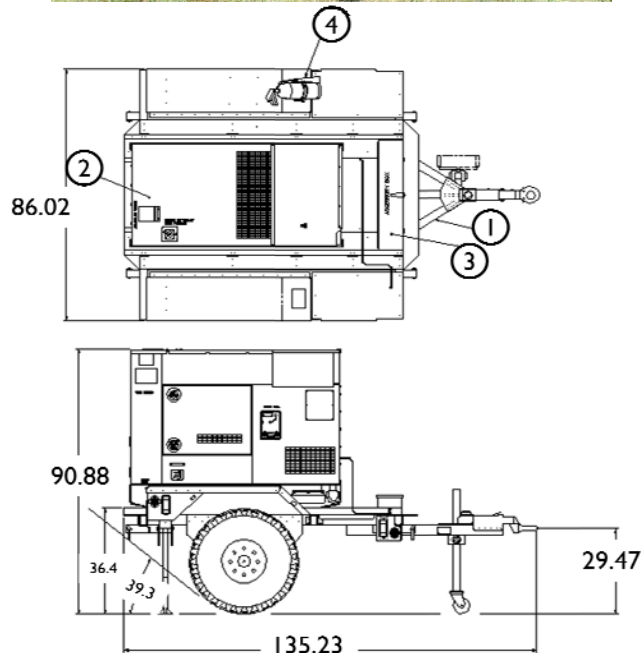

FIND	COMPONENT	QTY	IDENTIFIER
1	Light Tactical Trailer (LTT) (PU-801A)	1	97403-13230E6565
2	TQG set, DED, 15 kW, 50/60 Hz, MEP-804A	1	6115-01-274-7388
3	Accessory box	1	97403-13229E7946
4	Fire extinguisher, 5 lb., A-A-1106	1	4210-00-270-4512

Figure E- 25 PU-801A

MIL-HDBK-633A  
APPENDIX E

15 kW TQ Power Unit, 50/60 Hz, TRLMTD

Identification Data					
Description	15 kW TQ POWER UNIT, 50/60 Hz, TRLMTD			Camouflage: 97403-13228E1614	
<b>Model</b>	<b>NSN</b>	<b>LIN</b>	<b>SSN</b>	<b>ASSEMBLY</b>	<b>SPEC</b>
PU-802	6115-01-317-2138	G53778	R62700	TA-13229E5740	not procurable
Technical Manual	Operator, Unit and Direct Support			TM 9-6115-661-13&P	
Physical Characteristics					
<b>Dimensions LWH (in) &amp; (Cube) (ft<sup>3</sup>)</b>	<b>Ship Cube (ft<sup>3</sup>)</b>		<b>Wet Weight (lbs)</b>	<b>Ship Weight (lbs)</b>	
165 x 95 x 84 & (754)	754		5040	4920	

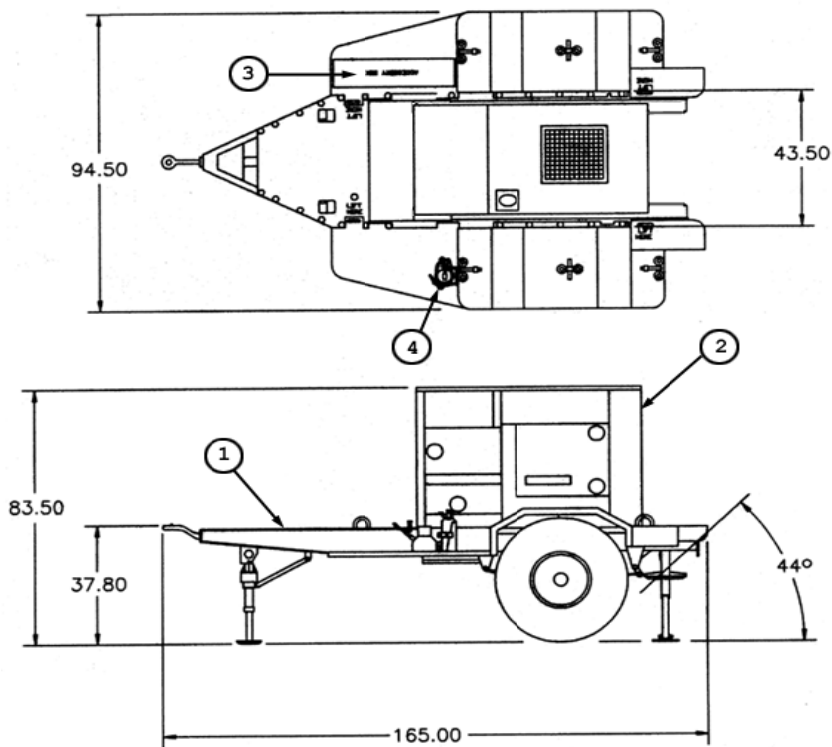

FIND	COMPONENT	QTY	IDENTIFIER
1	2-1/2 Ton modified trailer, M200A1	1	97403-13229E9632
2	TQ Gen set, DED, 15 kW, 50/60 Hz, MEP-804A	1	6115-01-274-7388
3	Accessory box	1	97403-13229E7946
4	Fire extinguisher, 5 lb., A-A-1106	1	4210-00-270-4512

Figure E- 26 PU-802

MIL-HDBK-633A  
APPENDIX E

PP-AN/MJQ-15, POWER PLANT, DED, 15 kW, 400 Hz, TRLMTD

Identification Data					
Description	POWER PLANT, DED, 15 kW, 400 Hz, TRLMTD			Camouflage: 97403-13226E7154	
<b>Model</b>	<b>NSN</b>	<b>LIN</b>	<b>SSN</b>	<b>ASSEMBLY</b>	<b>SPEC</b>
PP-AN/MJQ-15	6115-00-400-7591	P28075	M563	TA-13220E8042	not procurable
Physical Characteristics					
<b>Dimensions LWH (in) &amp; (Cube) (ft<sup>3</sup>)</b>	<b>Ship Cube (ft<sup>3</sup>)</b>		<b>Wet Weight (lbs)</b>	<b>Ship Weight (lbs)</b>	
161.9x95.5x85.0 (each of two units)	800 (each unit)		Unit A: 6180 Unit B: 6155	Unit A: 6020 Unit B: 6000	

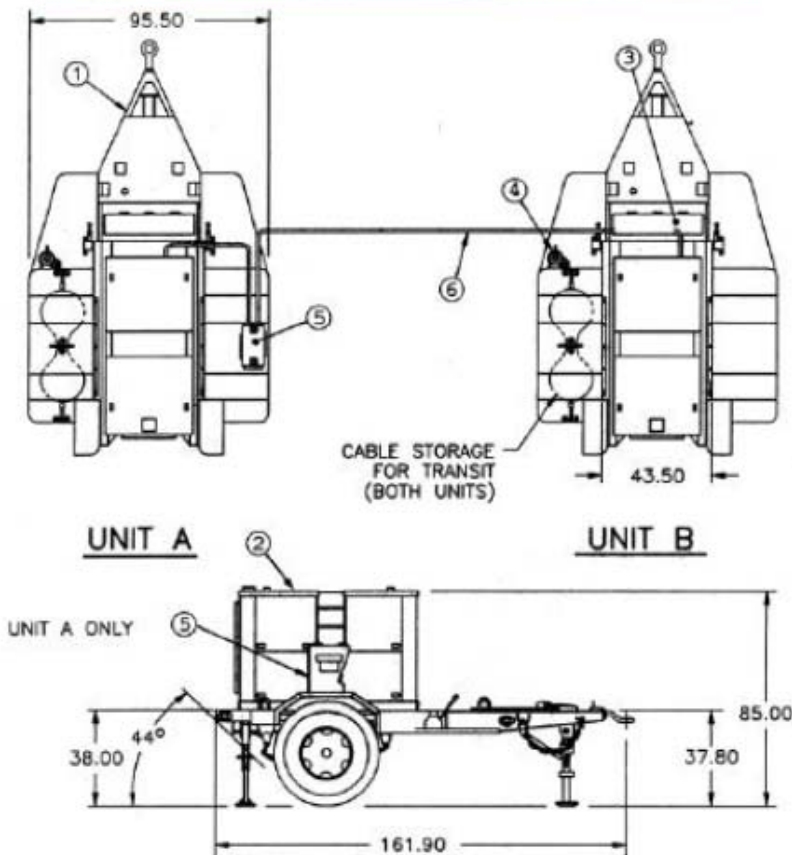

COMPONENT	QTY	FIND	IDENTIFIER
2-1/2 ton flatbed trailer, M200A1	2	1	97403-13214E1257
Generator set, DED, 15 kW, 400 Hz, MEP-113A	2	2	6115-00-118-1244
Accessory box	2	3	97403-13226E7737
Fire extinguisher, 5 lb., A-A-1106	2	4	4210-00-270-4512
Switch box (unit A), 97403-13220E6400 (old)	1	5	97403-13229E5795
Cable assembly	1	6	97403-13220E6427

Figure E- 27 PP-AN/MJQ-15

**MIL-HDBK-633A  
APPENDIX E**

**15 kW TQ Power Plant, 400 Hz, TRLMTD**

Identification Data					
Description	15kW TQ POWER PLANT, 400 Hz, TRLMTD			Camouflage: 97403-13228E1614	
<b>Model</b>	<b>NSN</b>	<b>LIN</b>	<b>SSN</b>	<b>ASSEMBLY</b>	<b>SPEC</b>
PP-AN/MJQ-39	6115-01-299-6034	P42614	R62700	TA-13229E5690	not procurable
Technical Manual	Operator, Unit and Direct Support			TM 9-6115-661-13&P	
Physical Characteristics					
<b>Dimensions (LWH (in)) &amp; (Cube) (ft<sup>3</sup>)</b>	<b>Ship Cube (ft<sup>3</sup>)</b>		<b>Wet Weight (lbs)</b>	<b>Ship Weight (lbs)</b>	
165 x 95 x 84 & (754) each	754 each		Unit A: 4863 Unit B: 4893	Unit A: 4765 Unit B: 4765	

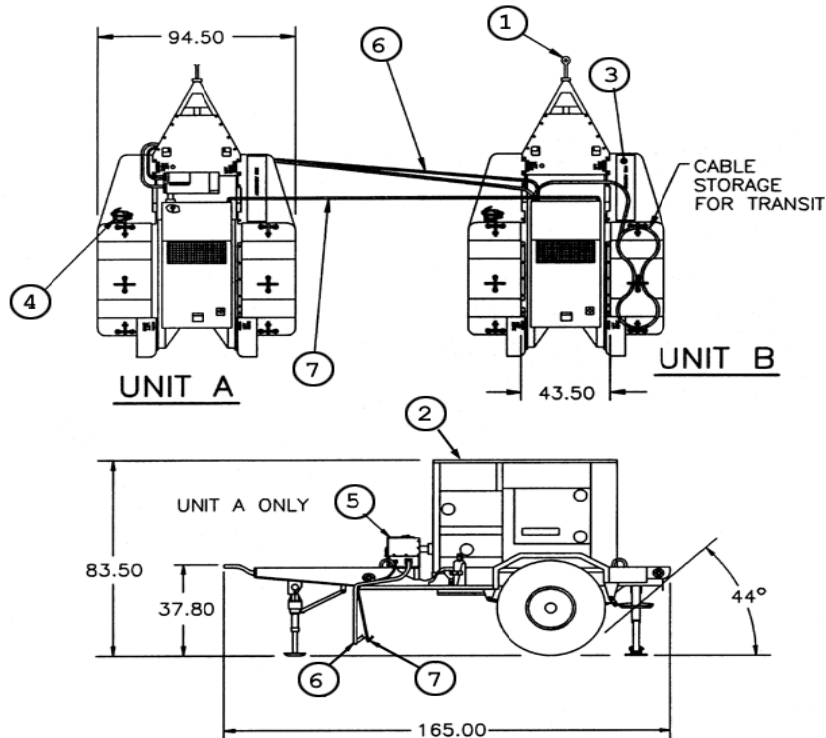

FIND	COMPONENT	QTY	IDENTIFIER
1	2-1/2 Ton modified trailer, M200A1	2	97403-13229E9632
2	TQ Gen set, DED, 15 kW, 400 Hz, MEP-814A	2	6115-01-274-7393
3	Accessory box	2	97403-13229E7946
4	Fire extinguisher, 5 lb., A-A-1106	2	4210-00-270-4512
5	Switch box (unit A)	1	97403-13229E5795-1
6	Cable assembly (unit B)	1	97403-13229E5674
7	Paralleling cable assembly,	2	30554-88-22209

Figure E- 28 PP-AN/MJQ-39

**MIL-HDBK-633A  
APPENDIX E**

**15 kW TQ Power Plant, 50/60 Hz, TRLMTD**

Identification Data					
Description	15kW TQ POWER PLANT, 50/60 Hz, TRLMTD			Camouflage: 97403-13228E1613	
<b>Model</b>	<b>NSN</b>	<b>LIN</b>	<b>SSN</b>	<b>ASSEMBLY</b>	<b>SPEC</b>
PP-AN/MJQ-48	6115-01-540-8433	P01012	R62700	TA-13230E7015	not procurable
Technical Manual	Operator, Unit and Direct Support			TM 9-6115-661-13&P	
Physical Characteristics					
<b>Dimensions (LWH (in)) &amp; (Cube) (ft<sup>3</sup>)</b>	<b>Ship Cube (ft<sup>3</sup>)</b>		<b>Wet Weight (lbs)</b>	<b>Ship Weight (lbs)</b>	
135 x 86 x 91 & (611) each	611 each		Unit A: 3570 Unit B: 3570	Unit A: 3470 Unit B: 3470	

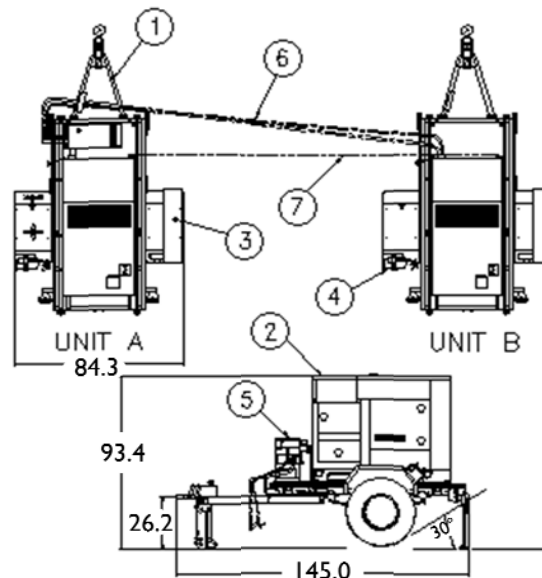

FIND	COMPONENT	QTY	IDENTIFIER
1	M116A3 Trailer AN/MJQ-48	2	97403-13230E6829
2	TQ Gen set, DED, 15 kW, 50/60 Hz, MEP-804A	2	6115-01-274-7388
3	Accessory box	2	97403-13229E7946
4	Fire extinguisher, 5 lb., A-A-1106	2	4210-00-270-4512
5	Switch box (unit A)	1	97403-13229E5795-1
6	Cable assembly (unit B)	1	97403-13229E5674
7	Paralleling cable assembly,	2	30554-88-22209

Figure E- 29 PP-AN/MJQ-48

**MIL-HDBK-633A  
APPENDIX E**

**15 kW TQ Power Plant, 50/60 Hz, TRLMTD**

Identification Data					
Description	15kW TQ POWER PLANT, 50/60 Hz, TRLMTD			Camouflage: 97403-13228E1614	
<b>Model</b>	<b>NSN</b>	<b>LIN</b>	<b>SSN</b>	<b>ASSEMBLY</b>	<b>SPEC</b>
PP-AN/MJQ-48A	6115-01-540-9465	P01012	R62700	TA-13230E7016	not procurable
Technical Manual	Operator, Unit and Direct Support			TM 9-6115-661-13&P	
Physical Characteristics					
<b>Dimensions (LWH (in)) &amp; (Cube) (ft<sup>3</sup>)</b>	<b>Ship Cube (ft<sup>3</sup>)</b>		<b>Wet Weight (lbs)</b>	<b>Ship Weight (lbs)</b>	
135 x 86 x 91 & (611) each	611 each		Unit A: 3570, Unit B: 3570	Unit A: 3470, Unit B: 3470	

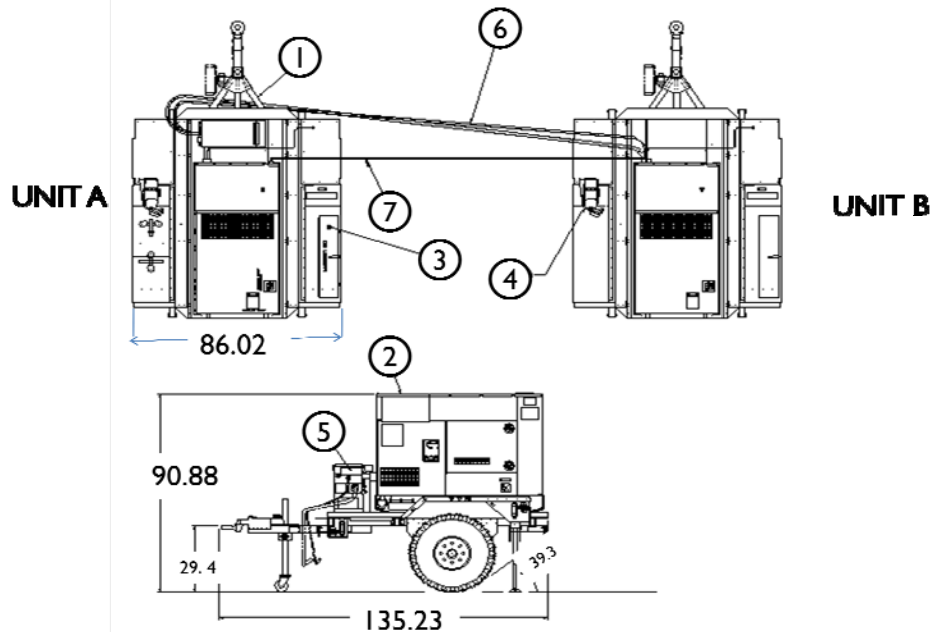

FIND	COMPONENT	QTY	IDENTIFIER
1	Light Tactical Trailer (LTT) AN/MJQ-48A	2	97403-13230E6565
2	TQ Gen set, DED, 15 kW, 50/60 Hz, MEP-804A	2	6115-01-274-7388
3	Accessory box	2	97403-13229E7946
4	Fire extinguisher, 5 lb., A-A-1106	2	4210-00-270-4512
5	Switch box (unit A)	1	97403-13229E5795-1
6	Cable assembly (unit B)	1	97403-13229E5674
7	Paralleling cable assembly,	2	30554-88-22209

Figure E- 30 PP-AN/MJQ-48A



**MIL-HDBK-633A  
APPENDIX E**

**30 kW, DED, Generator Set**

Identification data						
Nomenclature	Gen Set, DED, 30 kW, 50/60 Hz			Gen Set, DED, 30 kW, 400 Hz		
Model Number	MEP-005A			MEP-114A		
NSN	6115-00-118-1240			6115-00-118-1248		
LIN	J36109			J36725		
SSN	M532			M501		
Trailer Mounted Configurations	PU-406B/M; <a href="#">Figure E- 32</a> ; PU-803, <a href="#">Figure E- 34</a> ; AN/MJQ-10A; <a href="#">Figure E- 36</a> ; AN/MJQ-40, <a href="#">Figure E- 37</a>			PU-760/M; <a href="#">Figure E- 33</a> ; PU-804, <a href="#">Figure E- 35</a>		
Physical Characteristics						
Dimensions LWH (in)	79.3 x 35.8 x 54.6 (Cube: 90 ft <sup>3</sup> )			79.3 x 35.8 x 54.6 (Cube:90 ft <sup>3</sup> )		
Weight (lbs)	2850			3000		
Engine	6 cylinder Diesel, 57 hp @ 1800 RPM (60 Hz), liquid cooled, 24 Volt starter.			6 cylinder Diesel, 64 hp @ 2000 RPM (400 Hz), liquid cooled, 24 Volt starter		
Fuels	Diesel: DL-1, DL-2 and Jet fuel: JP-8, Jet A-1.					
Fuel Capacity	26 gal.					
Instrumentation	Hourmeter, voltmeter, frequency meter, ammeter, wattmeter, oil pressure gage, battery charging ammeter, fault indicating system, temperature, fuel.					
Performance Characteristics						
Electric Power Rating	30 kW, 60/400 Hz (25 kW, 50 Hz) @ 0.8 pf from -25°F (-65°F with winterization kit) to 125°F/MSL, 107°F/5000 ft.					
Environmental Capability	-25°F(-65°F with winterization kit) to 125°F, rain, humidity, altitude, sand/dust, transportation, cold storage, salt spray, fungus.					
Protective Devices	Overload, over voltage, short circuit, reverse power, low oil pressure, high temperature, low fuel, overspeed.					
Fuel Consumption	3 gal/hour @ rated load					
Human Factors	MIL-STD-1474. Operable in arctic and NBC clothing.					
Noise	80 dBA @ 25 feet.					
Reliability (MTBF)	50/60 Hz: 670 hr (spec);			400 Hz: 370 hr (spec).		
Electrical Characteristics						
Voltage Con:	120/208 V, 3 phase, 4 wire; 240/416 V, 3 phase, 4 wire.					
Operating Frequency	50 Hz		60 Hz		400 Hz	
Connection	120/208V	240/416V	120/208V	240/416V	120/208V	240/416V
Voltage Adj Range	190 213	380 426	197 240	395 480	197-229	395 458
Electrical	Drip proof generator enclosure, fungus & moisture treated, solid state voltage regulator, brushless rotary alternator.					
Electrical Performance						
Electric Power Quality	50/60 Hz			400 Hz		
	Volt	Frequency		Volt	Frequency	
Regulation	3%	2-3% (adj)		1%	0.25%	
Short term steady state stab (30 sec)	2%	2%		1%	0.5%	
Long term steady state stab (4 hr)	4%	3%		2%	1%	
Application/rejection of rated load/rec.time	20% / 3 sec	3% /4% /3 sec		12% /0.5 sec	1.5% /1 sec	
Motor load/recovery time	40% dip /5 sec			25% dip/0.7 sec		
Max waveform deviation factor	5%			5%		
Individual waveform harmonic	2%			2%		
EMI	Suppressed to MIL-STD-461 limits.					
EMP	none					
Optional Equipment						
Description	NSN	Weight (lbs)	Effect on Dim.(in)			
Fuel burning winterization kit	6115-00-463-9083	45	internal			
Electrical winterization kit	6115-00-463-9085	40	internal			
Aux fuel burning winterization kit	6115-00-463-9098	350	41 x 40 x 26 (Aux)			
Aux electrical winterization kit	6115-00-463-9099	260	36 x 27 x 19 (Aux)			
Remote control box	6115-00-420-8490	8	internal			
Load bank	6115-00-463-9088		L+9			
Wheel mounting kit	6115-00-463-9094	564	L+8 W+32 H+9			
Auto load tranf panel 60 Hz	6115-00-471-7932	825	44 x 19 x 42 (Aux)			
Paralleling cable	6140-00-197-4934	4	negligible			
Precise relay assembly	6115-00-368-8202		internal			

**MIL-HDBK-633A  
APPENDIX E**

Spark arrester kit	2990-01-032-0756	7.5	L+12
Technical Manuals			
Army	Air Force	Marine Corps	Navy
TM5-6115-465-12	TO35C2-3-446-1	TM 06858B/06859D-12	NAVFAC P-8-625-12
TM5-6115-465-34	TO35C2-3-446-2	TM 06858B/06859D-34	NAVFAC P-8-625-34
TM5-6115-465-24P	TO35C2-3-446-4	SL-4-06858B/06859P	NAVFAC P-8-625-24P
LO-5-6115-465-12		LO-06858A-06859A-12	



MEP-005A or MEP-114A

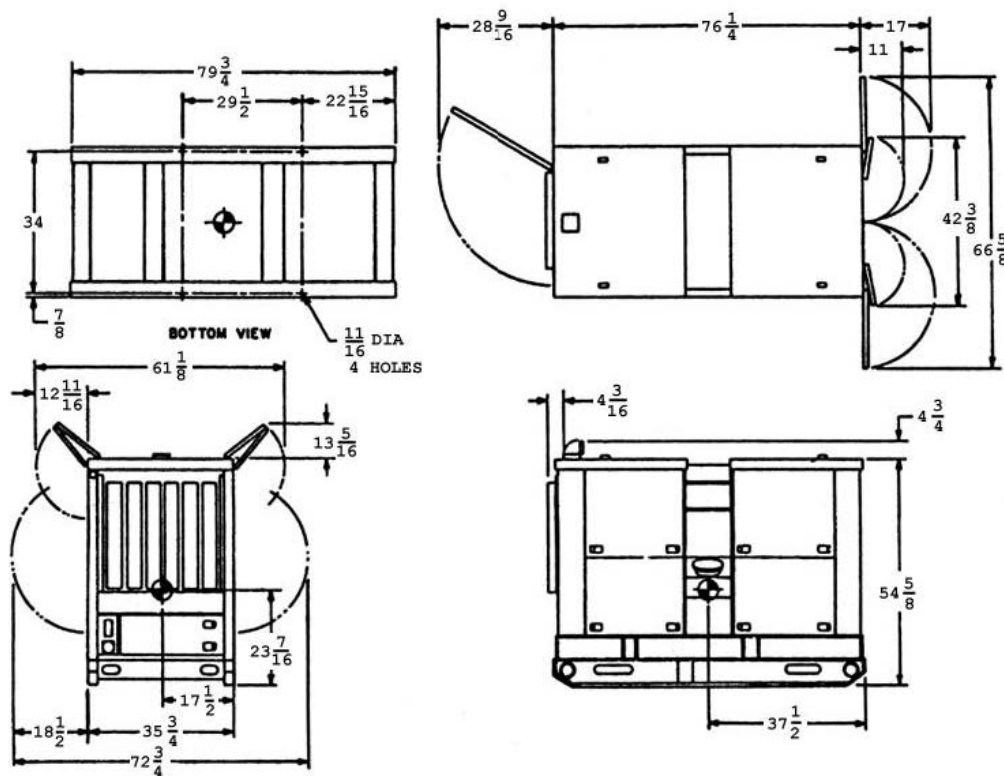
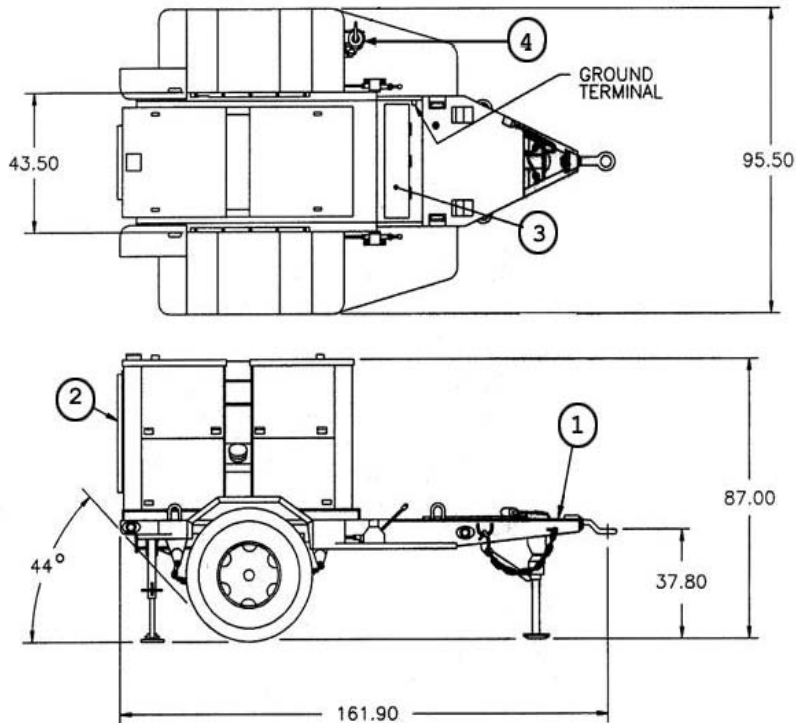

Figure E- 31 30kW, DED, Generator Set

MIL-HDBK-633A  
APPENDIX E

PU-406B/M, POWER UNIT, DED, 30 kW, 50/60 Hz, TRLMTD

Identification Data					
Description	POWER UNIT, DED, 30 kW, 50/60 Hz, TRLMTD			Camouflage: 97403-13226E7492	
<b>Model</b>	<b>NSN</b>	<b>LIN</b>	<b>SSN</b>	<b>ASSEMBLY</b>	<b>SPEC</b>
PU-406B/M	6115-00-394-9576	J36383	M543	TA-13220E6325	not procurable
Physical Characteristics					
<b>Dimensions LWH (in) &amp; (Cube) (ft<sup>3</sup>)</b>		<b>Ship Cube (ft<sup>3</sup>)</b>		<b>Wet Weight (lbs)</b>	<b>Ship Weight (lbs)</b>
161.9 x 95.5 x 87.0		818		6530	6380



COMPONENT	QTY	FIND	IDENTIFIER
2-1/2 Ton modified Trailer, M200A1	1	1	97403-13214E1257
Generator set, DED, 30 kW, 60 Hz, MEP-005A	1	2	6115-00-118-1240
Accessory box	1	3	97403-13226E7737
Fire extinguisher, 5 lb., A-A-1106	1	4	4210-00-270-4512

Figure E- 32 PU-406B/M

MIL-HDBK-633A  
APPENDIX E

PU-760/M, POWER UNIT, DED, 30 kW, 400 Hz, TRLMTD

Identification Data					
Description	POWER UNIT, DED, 30 kW, 400 Hz, TRLMTD			Camouflage: 97403-13226E7492	
<b>Model</b>	<b>NSN</b>	<b>LIN</b>	<b>SSN</b>	<b>ASSEMBLY</b>	<b>SPEC</b>
PU-760/M	6115-00-394-9581	G53871	M595	TA-13220E6341	not procurable
Physical Characteristics					
<b>Dimensions LWH (in) &amp; (Cube) (ft<sup>3</sup>)</b>		<b>Ship Cube (ft<sup>3</sup>)</b>		<b>Wet Weight (lbs)</b>	<b>Ship Weight (lbs)</b>
161.9 x 95.5 x 87.0		818		6680	5380

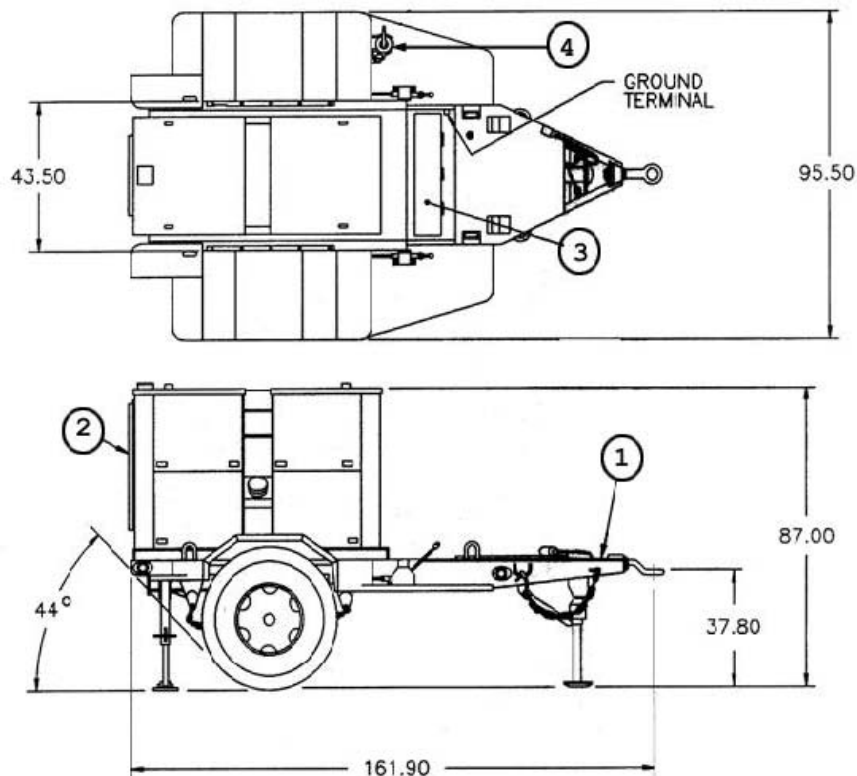

COMPONENT	QTY	FIND	IDENTIFIER
2-1/2 Ton modified Trailer, M200A1	1	1	97403-13214E1257
Generator set, DED, 30 kW, 400 Hz, MEP-114A	1	2	6115-00-118-1248
Accessory box	1	3	97403-13226E7737
Fire extinguisher, 5 lb., A-A-1106	1	4	4210-00-270-4512

Figure E- 33 PU-760/M

**MIL-HDBK-633A  
APPENDIX E**

PU-803, TQ POWER UNIT, DED, 30kW, 50/60 Hz, TRLMTD

Identification Data					
Description	TQ POWER UNIT, DED, 30kW, 50/60 Hz, TRLMTD			Camouflage: 97403-13228E1615	
<b>Model</b>	<b>NSN</b>	<b>LIN</b>	<b>SSN</b>	<b>ASSEMBLY</b>	<b>SPEC</b>
<b>PU-803</b>	6115-01-317-2136	G35851	M54300	TA-13229E5745	not procurable
Physical Characteristics					
<b>Dimensions LWH (in) &amp; (Cube) (ft<sup>3</sup>)</b>		<b>Ship Cube (ft<sup>3</sup>)</b>		<b>Wet Weight (lbs)</b>	<b>Ship Weight (lbs)</b>
165.0 x 94.5 x 83.5		770		5900	6380

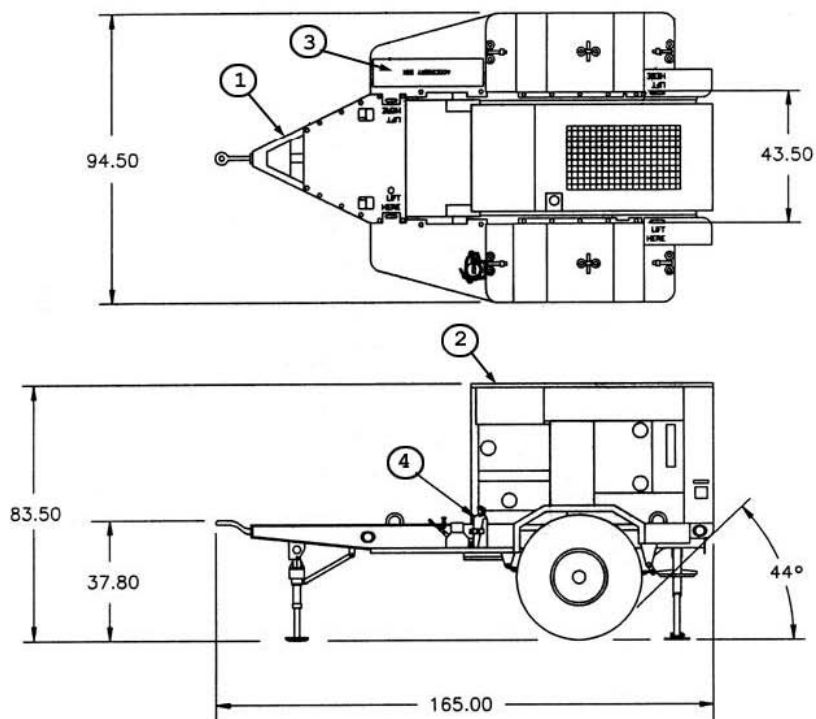

COMPONENT	QTY	FIND	IDENTIFIER
2-1/2 Ton modified trailer, M200A1	1	1	97403-13214E1257
TQ Gen set, DED, 30 kW, 50/60 Hz, MEP-805A	1	2	6115-01-274-7389
Accessory box	1	3	97403-13229E7946
Fire extinguisher, 5 lb., A-A-1106	1	4	4210-00-270-4512

Figure E- 34 PU-803

**MIL-HDBK-633A  
APPENDIX E**

PU-804, TQ POWER UNIT, DED, 30kW, 400 Hz, TRLMTD

Identification Data					
Description	TQ POWER UNIT, DED, 30kW, 400 Hz, TRLMTD			Camouflage: 97403-13228E1615	
<b>Model</b>	<b>NSN</b>	<b>LIN</b>	<b>SSN</b>	<b>ASSEMBLY</b>	<b>SPEC</b>
PU-804	6115-01-317-2135	G35919	M59500	TA-13229E5750	not procurable
Physical Characteristics					
<b>Dimensions LWH (in) &amp; (Cube) (ft<sup>3</sup>)</b>	<b>Ship Cube (ft<sup>3</sup>)</b>		<b>Wet Weight (lbs)</b>	<b>Ship Weight (lbs)</b>	
165.0 x 94.5 x 83.5	770		5730 .	5930	

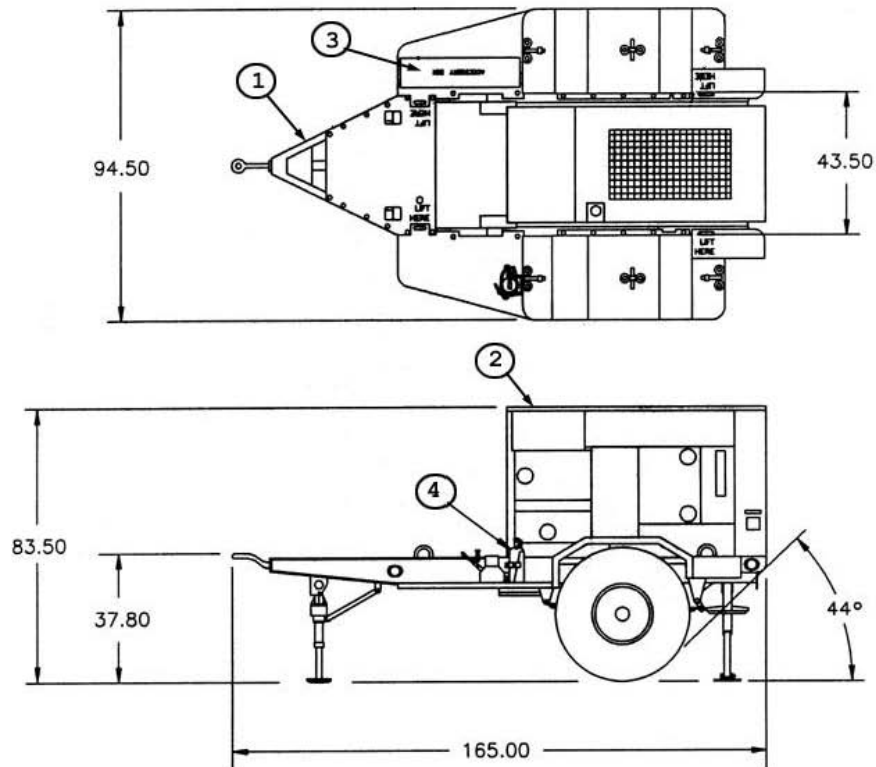

COMPONENT	QTY	FIND	IDENTIFIER
2-1/2 Ton modified trailer, M200A1	1	1	97403-13214E1257
TQ Generator set, DED, 30 kW, 400 Hz, MEP-815A	1	2	6115-01-274-7394
Accessory box	1	3	97403-13229E7946
Fire extinguisher, 5 lb., A-A-1106	1	4	4210-00-270-4512

Figure E- 35 PU-804

**MIL-HDBK-633A  
APPENDIX E**

**PP-AN/MJQ-10A, POWER PLANT, DED, 30 kW, 50/60 Hz, TRLMTD**

Identification Data					
Description	POWER PLANT, DED, 30 kW, 50/60 Hz, TRLMTD			Camouflage: 97403-13226E7492	
<b>Model</b>	<b>NSN</b>	<b>LIN</b>	<b>SSN</b>	<b>ASSEMBLY</b>	<b>SPEC</b>
PP-AN/MJQ-10A	6115-00-394-9582	P27819	M519	TA-13220E6335	not procurable
Physical Characteristics					
<b>Dimensions LWH (in) &amp; (Cube) (ft<sup>3</sup>)</b>	<b>Ship Cube (ft<sup>3</sup>)</b>		<b>Wet Weight (lbs)</b>		<b>Ship Weight (lbs)</b>
161.9x95.5x87.0 (each)	818 (each unit)		Unit A: 6630 Unit B: 6620		Unit A: 6480 Unit B: 6420

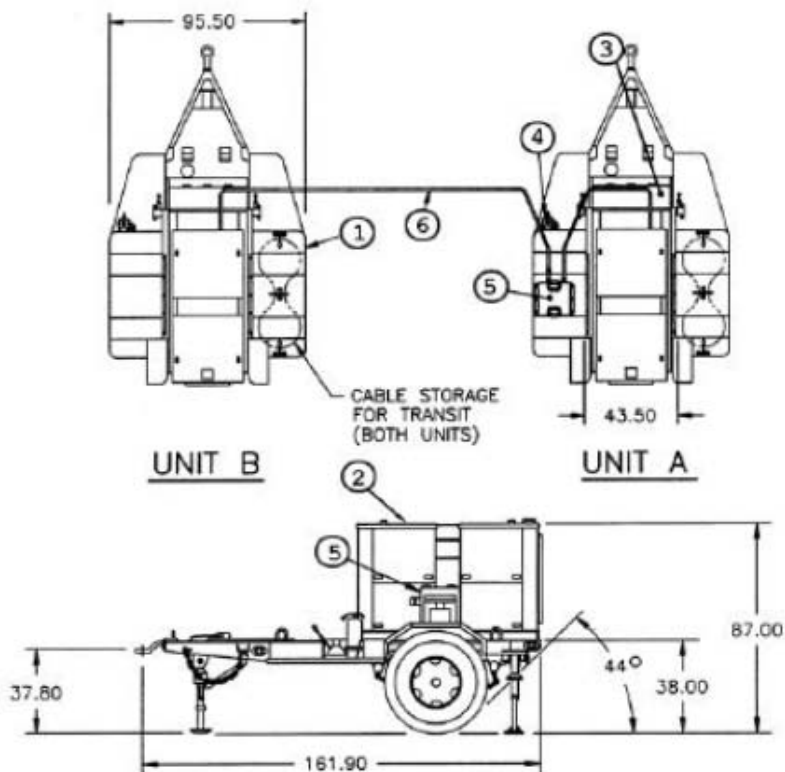

COMPONENT	QTY	FIND	IDENTIFIER
2-1/2 ton flatbed trailer, M200A1	2	1	97403-13214E1257
Generator set, DED, 30 kW, 50/60 Hz, MEP-005A	2	2	6115-00-118-1240
Accessory box	2	3	97403-13226E7737
Fire extinguisher, 5 lb., A-A-1106	2	4	4210-00-270-4512
Switch box (unit A), 97403-13229E6780 (old)	1	5	97403-13229E5795
Cable assembly	1	6	97403-13220E7718

Figure E- 36 PP-AN/MJQ-10A

**MIL-HDBK-633A  
APPENDIX E**

AN/MJQ-40, TQ POWER PLANT, DED, 30kW, 50/60 Hz, TRLMTD

Identification Data					
Description	TQ POWER PLANT, DED, 30kW, 50/60 Hz, TRLMTD			Camouflage: 97403-13228E1615	
<b>Model</b>	<b>NSN</b>	<b>LIN</b>	<b>SSN</b>	<b>ASSEMBLY</b>	<b>SPEC</b>
AN/MJQ-40	6115-01-299-6033	P42126	M51900	TA-13229E5700	not procurable
Physical Characteristics					
<b>Dimensions LWH (in) &amp; (Cube) (ft<sup>3</sup>)</b>	<b>Ship Cube (ft<sup>3</sup>)</b>		<b>Wet Weight (lbs)</b>	<b>Ship Weight (lbs)</b>	
165.0x94.5x83.5 (each)	770 (2x)		Unit A: 5700 Unit B: 5740	Unit A: 6700 Unit B: 6740	

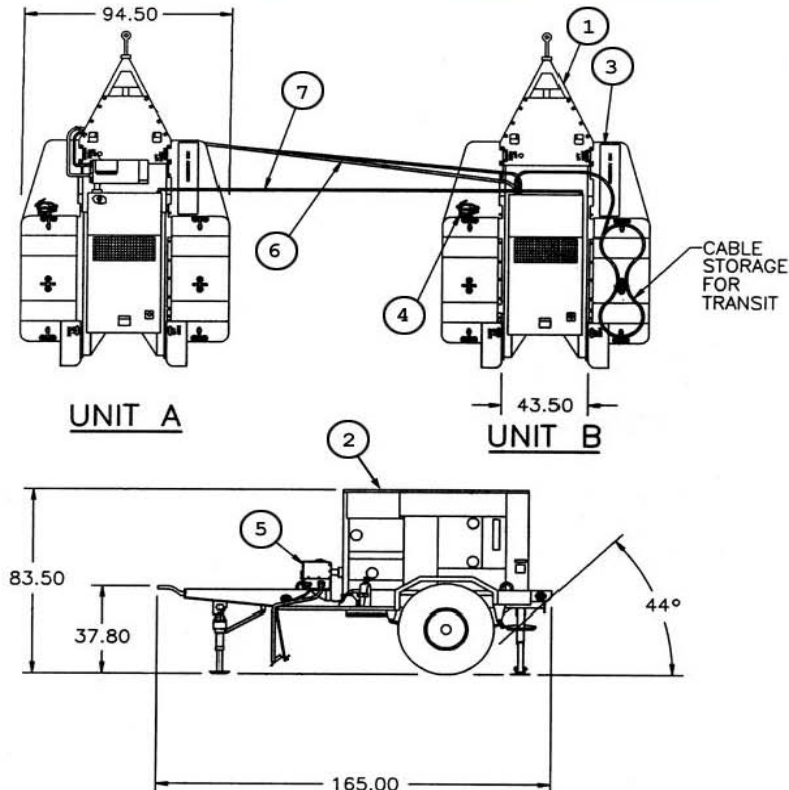

COMPONENT	QTY	FIND	IDENTIFIER
2-1/2 Ton modified trailer, M200A1	2	1	97403-13214E1257
TQ Generator set, DED, 30 kW, 50/60 Hz, MEP-805A	2	2	6115-01-274-7389
Accessory box	2	3	97403-13229E7946
Fire extinguisher, 5 lb., A-A-1106	2	4	4210-00-270-4512
Switch box (unit A)	1	5	97403-13229E5795
Cable assembly (unit B)	1	6	97403-13229E5738
Paralleling cable assembly	2	7	30554-88-22209

Figure E- 37 PP-AN/MJQ-40



**MIL-HDBK-633A  
APPENDIX E**

**60 kW, DED, Generator Set**

Identification Data						
Nomenclature	Gen Set, DED, 60kW, 50/60 Hz			Gen Set, DED, 60kW, 400 Hz		
Model Number	MEP-006A			MEP-115A		
NSN	6115-00-118-1243			6115-00-118-1253		
LIN	J38301			J38506		
SSN	M531					
Trailer Mounted Configurations	PU-650B/G; <a href="#">Figure E- 39</a> ; PU-805, <a href="#">Figure E- 41</a> ; AN/MJQ-12A; <a href="#">Figure E- 43</a> ; AM/MJQ-41, <a href="#">Figure E- 44</a>			PU-707A/M; <a href="#">Figure E- 40</a> ; PU-806, <a href="#">Figure E- 42</a>		
Physical Characteristics						
Dimensions (LWH)(in)	87.0 x 36.0 x 59.0 (Cube: 101 ft <sup>3</sup> )			87.0 x 36.0 x 59.0 (Cube: 101 ft <sup>3</sup> )		
Weight (lbs)	4240			4400		
Engine	6 cylinder Diesel, 167 hp @ 1800 RPM (60 Hz), liquid cooled, 24 Volt starter.			6 cylinder Diesel, 180 hp @ 2000 RPM (400 Hz), liquid cooled, 24 Volt starter.		
Fuels Diesel:.	DL-1, DL-2 and Jet fuel: JP-8, Jet A-1.					
Fuel Capacity	55 gal.					
Instrumentation	Hourmeter, voltmeter, frequency meter, ammeter, wattmeter, oil pressure gage, battery charging ammeter, fault indicating system, temperature, fuel.					
Performance Characteristics						
Electric Power Rating	60 kW, 60 or 400 Hz; 50 kW, 50 Hz @ 0.8 pf from -25°F (-65 F with winterization kit) to 125°F/MSL, 107°F/5000 ft.					
Environmental Capability	-25°F(-65°F with winterization kit) to 125°F, rain, humidity, altitude, sand/dust, transportation, cold storage, salt spray, fungus					
Protective Devices	Overload, over voltage, short circuit, reverse power, low oil pressure, high temperature, low fuel, overspeed					
Fuel Consumption	6 gal/hour @ rated load					
Human Factors	MIL-STD-1474. Operable in arctic and NBC clothing.					
Noise	86 dBA @ 25 feet.					
Reliability (MTBF)	50/60 Hz: 500 hr (spec);			400 Hz: 450 hr (spec)		
Electrical Characteristics						
Connection	120/208V, 3 phase, 4 wire			240/416V, 3 phase, 4 wire		
Frequency	50 Hz	60 Hz	400 Hz	50 Hz	60 Hz	400 Hz
Voltage Adj Range	190 - 213	197 - 240	197 - 229	380 - 426	395 - 480	395 - 458
Electrical	Drip proof generator enclosure, fungus & moisture treated, solid state voltage regulator, brushless rotary alternator.					
Electrical Performance						
Electric Power Quality	50/60 Hz			400 Hz		
	Volt	Frequency		Volt	Frequency	
Short term steady state stability(30 sec)	2%	2%		1%	0.5%	
Long term steady state stability (4 hr)	4%	3%		2%	1%	
Applic./rejec.of rated load/recovery time	20% /3 sec	3%/4%/3 sec		12% /0.5 sec	1.5%/1sec	
motor load /recovery	40% dip/ 5 sec			25% dip/ 0.7sec		
Max waveform deviation factor	5%			5%		
Individual waveform harmonic	2%			2%		
Regulation	3%	2-3% (adj)		1%	0.25%	
EMI	Suppressed to MIL-STD-461 limits.					
EMP	Not protected.					
Optional Equipment						
Description	NSN	Weight (lbs)	Effect on Dim.(in)			
Fuel burning winterization kit	6115-00-407-8314	45	Internal			
Electrical winterization kit	6115-00-455-7693	40	Internal			
Aux fuel burning winterization kit	6115-00-463-9098	350	41 x 40 x 26 (Aux)			
Aux electrical winterization kit	6115-00-463-9099	260	36 x 27 x 19 (Aux)			
Remote control box	6115-00-420-8490	8	Internal			
Load bank	6115-00-407-8322	272	H+15			
Wheel mounting kit	6115-00-463-9092	564	L+8 W+32 H+9			
Auto load tranf panel 60 Hz	6115-00-471-7932	825	44 x 19 x 42 (Aux)			
Paralleling cable	6140-00-197-4934	4	negligible			
Precise relay assembly 60Hz	6115-00-276-7622		internal			

**MIL-HDBK-633A  
APPENDIX E**

Auto standby panel, 400 Hz	6115-00-463-9096	825	44 x 19 x 42 (Aux)
Technical Manuals			
Army	Air Force	Marine Corps	Navy
TM5-6115-545-12	TO35C2-3-444-1	TM 00038G-12	P-8-626-12
TM5-6115-545-34	TO35C2-3-444-2	TM 00038G-34	P-8-626-34
TM5-6115-545-24P	TO35C2-3-444-4	SL-4-00038G	P-8-626-24P
LO-5-6115-545-12			

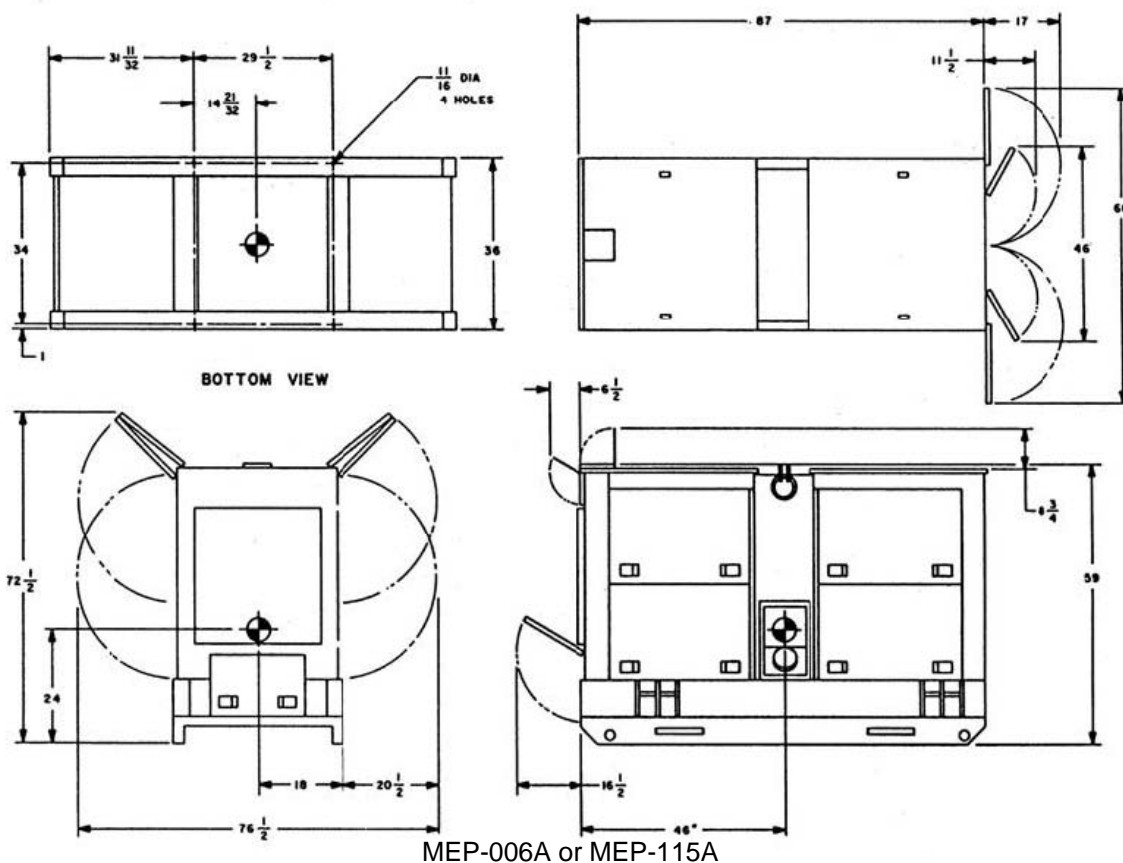
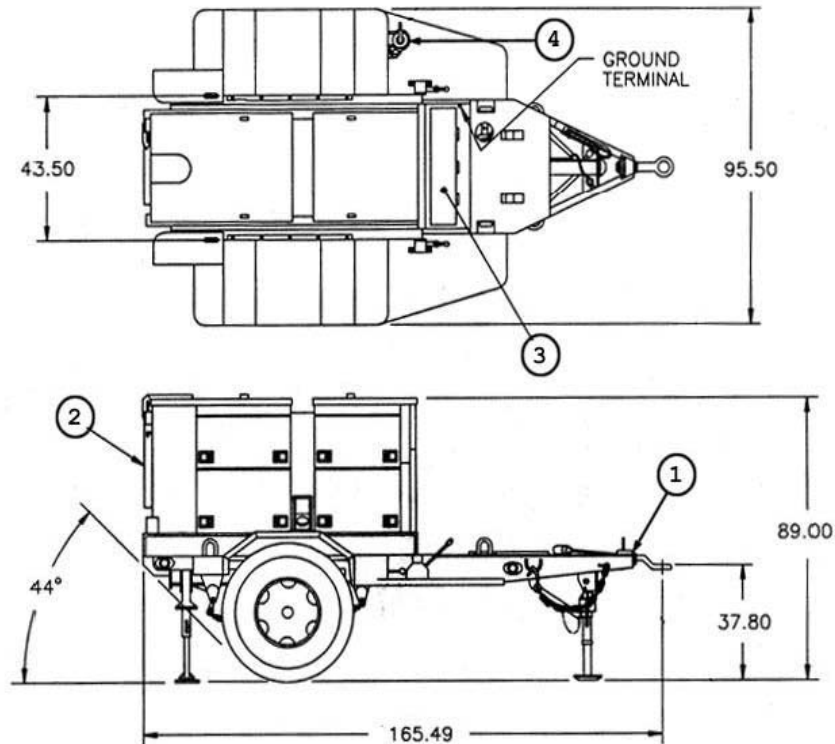

Figure E- 38 60kW, DED Generator Set

**MIL-HDBK-633A  
APPENDIX E**

**PU-650B/G, POWER UNIT, DED, 60kW, 50/60 Hz, TRLMTD**

Identification Data					
Description	POWER UNIT, DED, 60kW, 50/60 Hz, TRLMTD			Camouflage: 97403-13226E7494	
<b>Model</b>	<b>NSN</b>	<b>LIN</b>	<b>SSN</b>	<b>ASSEMBLY</b>	<b>SPEC</b>
PU-650B/G	6115-00-258-1622	J35629	M509	TA-13220E4454	not procurable
Physical Characteristics					
<b>Dimensions LWH (in) &amp; (Cube) (ft<sup>3</sup>)</b>	<b>Ship Cube (ft<sup>3</sup>)</b>		<b>Wet Weight (lbs)</b>	<b>Ship Weight (lbs)</b>	
165.5 x 95.5 x 89.0	837		8100	7800	



COMPONENT	QTY	FIND	IDENTIFIER
2-1/2 Ton modified Trailer, M200A1	1	1	97403-13214E1257
Generator set, DED, 60 kW, 60 Hz, MEP-006A	1	2	6115-00-118-1243
Fire extinguisher, 5 lb., A-A-1106	1	3	4210-00-270-4512
Accessory box	1	4	97403-13226E7737

Figure E- 39 PU-650B/G

MIL-HDBK-633A  
APPENDIX E

PU-707A/M, POWER UNIT, DED, 60kW, 400 Hz, TRLMTD

Identification Data					
Description	POWER UNIT, DED, 60kW, 400 Hz, TRLMTD			Camouflage: 97403-13226E7494	
<b>Model</b>	<b>NSN</b>	<b>LIN</b>	<b>SSN</b>	<b>ASSEMBLY</b>	<b>SPEC</b>
PU-707A/M	6115-00-394-9573	G52886	M510	TA-13220E6332	not procurable
Physical Characteristics					
<b>Dimensions LWH (in) &amp; (Cube) (ft<sup>3</sup>)</b>	<b>Ship Cube(ft<sup>3</sup>)</b>		<b>Wet Weight (lbs)</b>	<b>Ship Weight (lbs)</b>	
165.5 x 95.5 x 89.0	837		8200 .	7800	

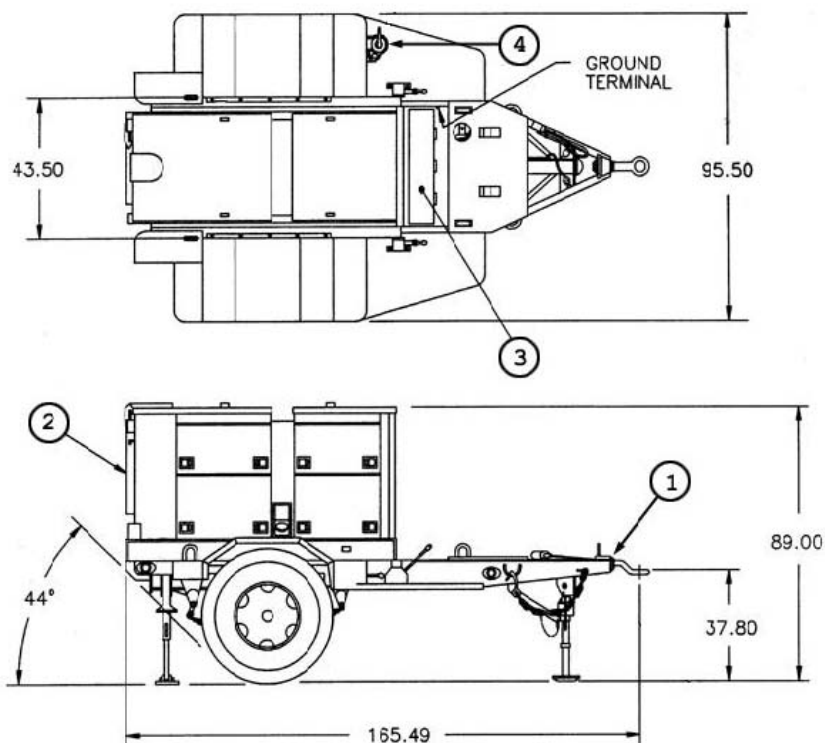

COMPONENT	QTY	FIND	IDENTIFIER
2-1/2 Ton modified Trailer, M200A1	1	1	97403-13214E1257
Generator set, DED, 60 kW, 400 Hz, MEP-115A	1	2	6115-00-118-1253
Fire extinguisher, 5 lb., A-A-1106	1	3	4210-00-270-4512
Accessory box	1	4	97403-13226E7737

Figure E- 40 PU-707A/M

MIL-HDBK-633A  
APPENDIX E

PU-805, TQ POWER UNIT, DED, 60kW, 50/60 Hz, TRLMTD

Identification Data					
Description	TQ POWER UNIT, DED, 60kW, 50/60 Hz, TRLMTD			Camouflage: 97403-13228E1616	
<b>Model</b>	<b>NSN</b>	<b>LIN</b>	<b>SSN</b>	<b>ASSEMBLY</b>	<b>SPEC</b>
PU-805	6115-01-317-2134	G78306	M50900	TA-13229E5755	not procurable
Physical Characteristics					
<b>Dimensions LWH (in) &amp; (Cube) (ft<sup>3</sup>)</b>	<b>Ship Cube(ft<sup>3</sup>)</b>		<b>Wet Weight (lbs)</b>	<b>Ship Weight (lbs)</b>	
165.0 x 94.5 x 86.3	770		6720	6920	

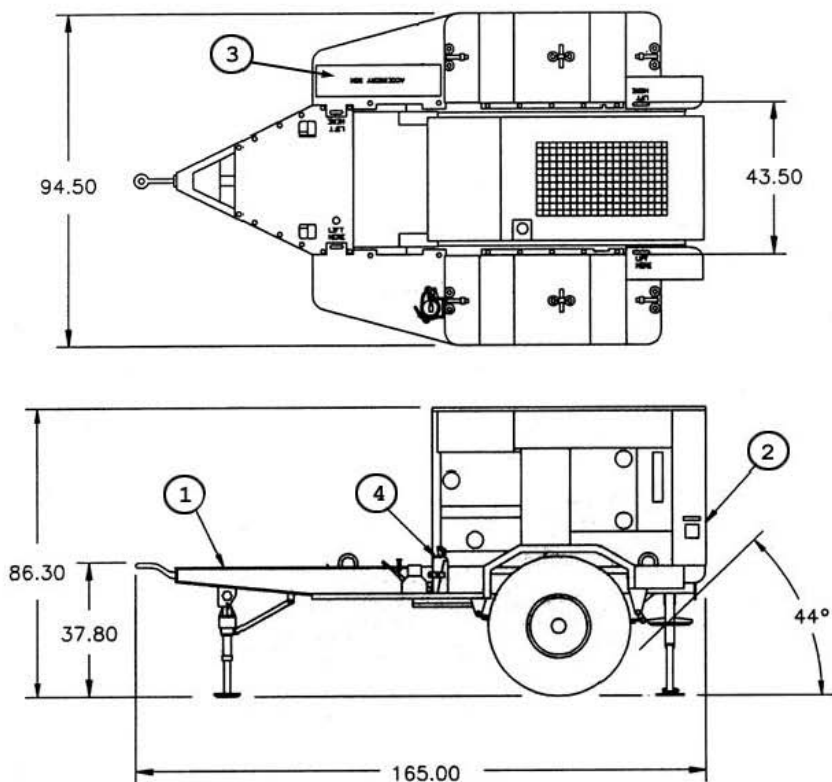

COMPONENT	QTY	FIND	IDENTIFIER
2-1/2 Ton modified trailer, M200A1	1	1	97403-13214E1257
TQ Gen set, DED, 60 kW, 50/60 Hz, MEP-806A	1	2	6115-01-274-7390
Accessory box	1	3	97403-13229E7946
Fire extinguisher, 5 lb., A-A-1106	1	4	4210-00-270-4512

Figure E- 41 PU-805

MIL-HDBK-633A  
APPENDIX E

PU-806, TQ POWER UNIT, DED, 60kW, 400 Hz, TRLMTD

Identification Data					
Description	TQ POWER UNIT, DED, 60kW, 400 Hz, TRLMTD			Camouflage: 97403-13228E1616	
<b>Model</b>	<b>NSN</b>	<b>LIN</b>	<b>SSN</b>	<b>ASSEMBLY</b>	<b>SPEC</b>
PU-806	6115-01-317-2133	G17460	M51000	TA-13229E5760	not procurable
Physical Characteristics					
<b>Dimensions LWH (in) &amp; (Cube) (ft<sup>3</sup>)</b>		<b>Ship Cube(ft<sup>3</sup>)</b>		<b>Wet Weight (lbs)</b>	<b>Ship Weight (lbs)</b>
165.0 x 94.5 x 86.3		770		6815	7015

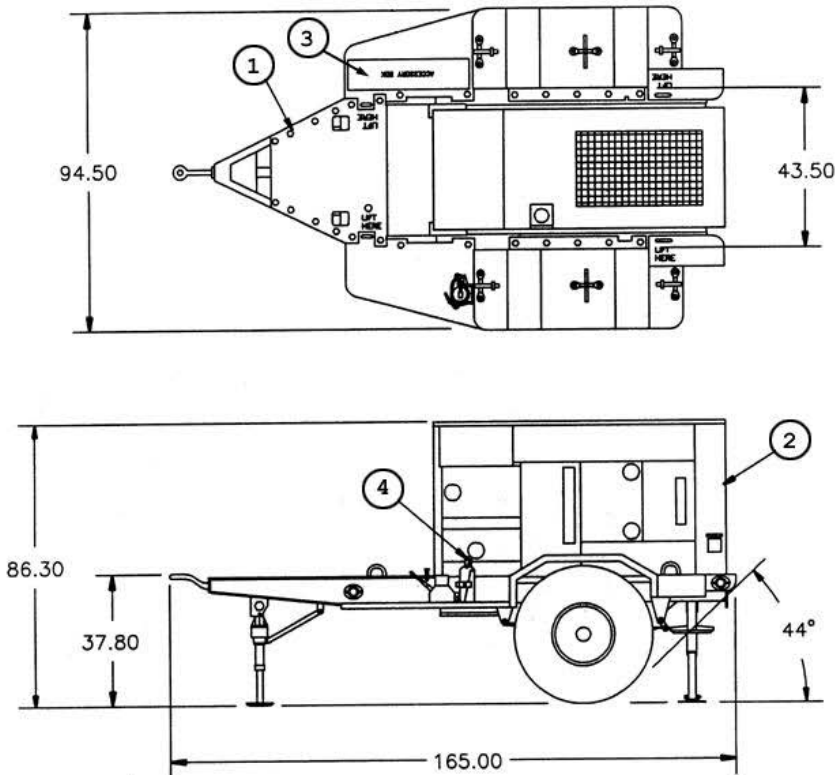

COMPONENT	QTY	FIND	IDENTIFIER
2-1/2 Ton modified trailer, M200A1	1	1	97403-13214E1257
TQ Generator set, DED, 60 kW, 400 Hz, MEP-816A	1	2	6115-01-274-7395
Accessory box	1	3	97403-13229E7946
Fire extinguisher, 5 lb., A-A-1106	1	4	4210-00-270-4512

Figure E- 42 PU-806

**MIL-HDBK-633A  
APPENDIX E**

**PP-AN/MJQ-12A, POWER PLANT, DED, 60kW, 50/60 Hz, TRLMTD**

Identification Data					
Description	POWER PLANT, DED, 60kW, 50/60 Hz, TRLMTD			Camouflage: 97403-13226E7494	
<b>Model</b>	<b>NSN</b>	<b>LIN</b>	<b>SSN</b>	<b>ASSEMBLY</b>	<b>SPEC</b>
PP-AN/MJQ-12A	6115-00-257-1602	P27823	M511	TA-13221E7350	not procurable
Physical Characteristics					
<b>Dimensions LWH (in) &amp; (Cube) (ft<sup>3</sup>)</b>		<b>Ship Cube (ft<sup>3</sup>)</b>		<b>Wet Weight (lbs)</b>	<b>Ship Weight (lbs)</b>
161.9 x 95.5 x 87.0 (each of 2 units)		818 (each unit)		Unit A: 6630 Unit B: 6620	Unit A: 6480 Unit B: 6420

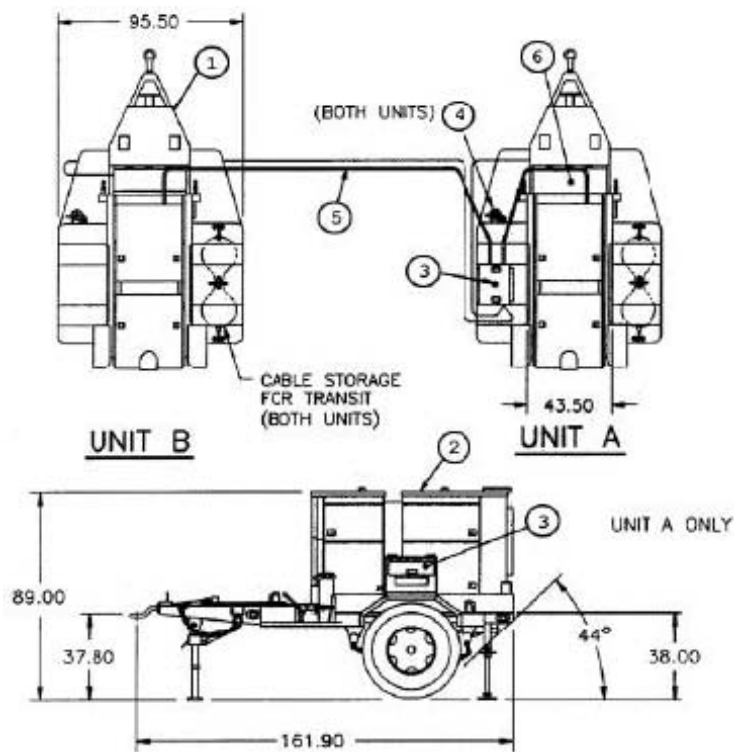

COMPONENT	QTY	FIND	IDENTIFIER
2-1/2 ton flatbed trailer, M200A1	2	1	97403-13214E1257
Generator set, DED, 60 kW, 50/60 Hz, MEP-006A	2	2	6115-00-118-1243
Switch box (unit A), 97403-13229E6776 (old)	1	3	97403-13229E5795
Fire extinguisher, 5 lb., A-A-1106	2	4	4210-00-270-4512
Cable assembly	1	5	97403-13226E7626
Accessory box	2	6	97403-13226E7737

Figure E- 43 PP-AN/MJQ-12A

**MIL-HDBK-633A  
APPENDIX E**

**PP-AN/MJQ-41, TQ POWER PLANT, DED, 60kW, 50/60 Hz, TRLMTD**

Identification Data					
Description	TQ POWER PLANT, DED, 60kW, 50/60 Hz, TRLMTD			Camouflage: 97403-13228E1616	
<b>Model</b>	<b>NSN</b>	<b>LIN</b>	<b>SSN</b>	<b>ASSEMBLY</b>	<b>SPEC</b>
PP-AN/MJQ-41	6115-01-303-7896	P42194	M51100	TA-13229E5710	not procurable
Physical Characteristics					
<b>Dimensions LWH (in) &amp; (Cube) (ft<sup>3</sup>)</b>	<b>Ship Cube (ft<sup>3</sup>)</b>		<b>Wet Weight (lbs)</b>	<b>Ship Weight (lbs)</b>	
165.0 x 94.5 x 86.3 (2x)	770 (2x)		Unit A: 6695 Unit B: 6745	Unit A: 7695 Unit B: 7745	

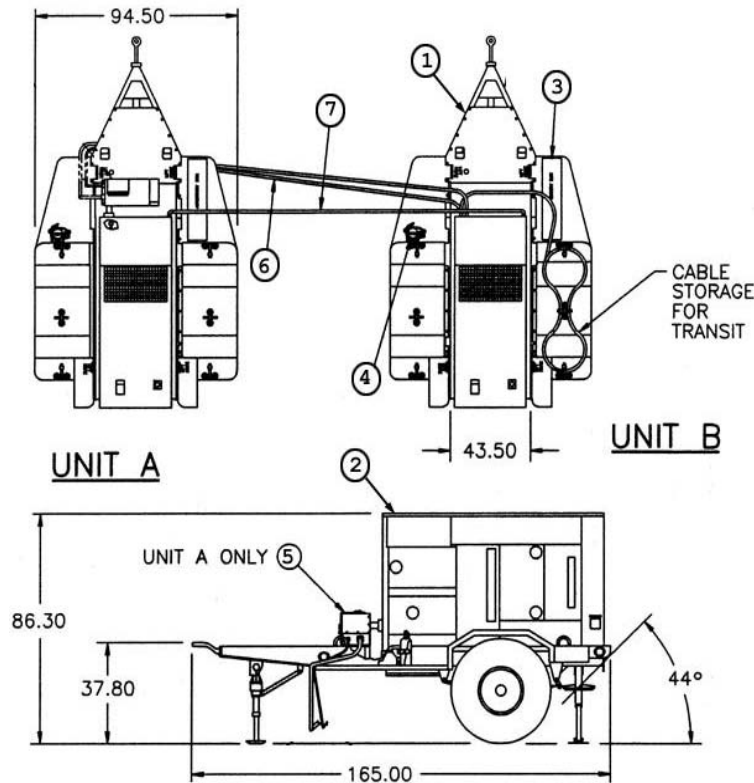

COMPONENT	QTY	FIND	IDENTIFIER
2-1/2 Ton modified trailer, M200A1	2	1	97403-13214E1257
TQ Generator set, DED, 60 kW, 400 Hz, MEP-806A	2	2	6115-01-274-7390
Accessory box	2	3	97403-13229E7946
Fire extinguisher, 5 lb., A-A-1106	2	4	4210-00-270-4512
Switch box (unit A)	1	5	97403-13229E5795
Cable assembly (unit B)	1	6	97403-13229E5741
Paralleling cable assembly	2	7	30554-88-22209

Figure E- 44 PP-AN/MJQ-41



**MIL-HDBK-633A  
APPENDIX E**

**100 kW Diesel Engine Driven Generator**

<b>Identification Data</b>			
Nomenclature	Gen Set, 100 kW, DED, 50/60 Hz		
Model Number	MEP-007B		
NSN	6115-01-036-6374		
LIN	J38712		
SSN	M544		
<b>Physical Characteristics</b>			
Dimensions LWH (in)	106.0 x 40.0 x 65.0 (Cube: 159 ft <sup>3</sup> .)		
Weight (lbs)	dry: 6680	wet: 7500	shipping: 8400
Engine	6 cylinder Diesel, 217 hp @ 1800 RPM, 24 VDC starter. Liquid cooled.		
Fuels	Diesel: DL-1, DL-2 and Jet fuel: JP-8, Jet A-1		
Fuel Capacity	Fuel tank: 91 gallons		
Instrumentation	On/off switch, hour, volt, frequency, ammeter, wattmeter, oil pressure, coolant temperature, battery charging ammeter, fuel level and fault indication.		
<b>Performance Characteristics</b>			
Electric Power Rating	100 kW, 60 Hz or 83.3 kW, 50 Hz @ 0.8 pf from -25°F (-65°F with winterization kit) to 125°F/MSL, 107°F/5000 ft.		
Environmental Capability	-25°F to 125°F, rain, humidity, altitude, sand/ dust, transportation, -65°F cold storage, salt spray, fungus.		
Protective Devices	Short circuit, overvoltage, overload, reverse power, low oil pressure, high temperature, low fuel, and overspeed.		
Fuel Consumption	8.5 gal/hour		
Human Factors	MIL-STD 1474		
Noise	85 dBA @ 25 ft.		
Reliability (MTBF)	680 hr. (specified)		
<b>Electrical Characteristics</b>			
Connection	120/208V, 3 phase, 4 wire		240/416V, 3 phase, 4 wire
Frequency	50 Hz	60 Hz	50 Hz      60 Hz
Voltage Adj Range	190 - 213	197 - 240	380 - 426      395 - 480
Electrical	Drip proof generator enclosure, fungus & moisture treated, solid state voltage regulator, solderless connectors, Brushless rotary exciter. Capable of parallel operation.		
EMI	Suppressed to MIL-STD-461 limits.		
EMP	Not protected		
<b>Electrical Performance</b>			
<b>Electric Power Quality</b>	<b>Volt</b>	<b>Frequency</b>	
Regulation	1%	0.25% (adj)	
Short term steady state stab (30 sec)	1%	0.5%	
Long term steady state stab (4 hr)	2%	1%	
Application/Rejection of rated load, recovery time	15% dip rise 0.5 sec	*4% @ 75% rated 2 sec load.	
Max waveform deviation factor	5%		
Individual waveform harmonic	2%		
Motor load / recovery	30% dip / 0.7 sec		
<b>Optional Equipment</b>			
<b>Description</b>	<b>NSN</b>	<b>Weight (lbs)</b>	<b>Effect on Dim.(in)</b>
Winterization Kit (fuel)	6115-00-xxx-xxxx		internal
Winterization Kit (elect)	6115-00-xxx-xxxx		internal
Winterization Kit, Aux, Fuel	6115-00-463-9098	350	41 x 40 x 26
Winterization Kit, Aux, Elect	6115-00-463-9098	260	36 x 27 x 19
Remote Control Box	6115-00-420-8490	8	internal
Load Bank	6115-00-463-9086	370	H+19
Wheel Mounting Kit	6115-00-463-9089	580	H+13, L+9, W+30
Panel, Auto, load transfer, 60Hz	6115-00-477-7932	825	44 x 19 x 42
<b>Technical Manuals</b>			
<b>Army</b>	<b>Air Force</b>	<b>Marine Corps</b>	<b>Navy</b>
TM5-6115-600-12	TO35C2-3-442-1	TM-07464-12	P-8-628-12
TM5-6115-600-34	TO35C2-3-442-2	TM-07464-34	P-8-628-34
TM5-6115-600-24P	TO35C2-3-442-4	SL-4-07464G	P-8-628-24P
LO-5-6115-600-12			

MIL-HDBK-633A  
APPENDIX E



MEP-007B

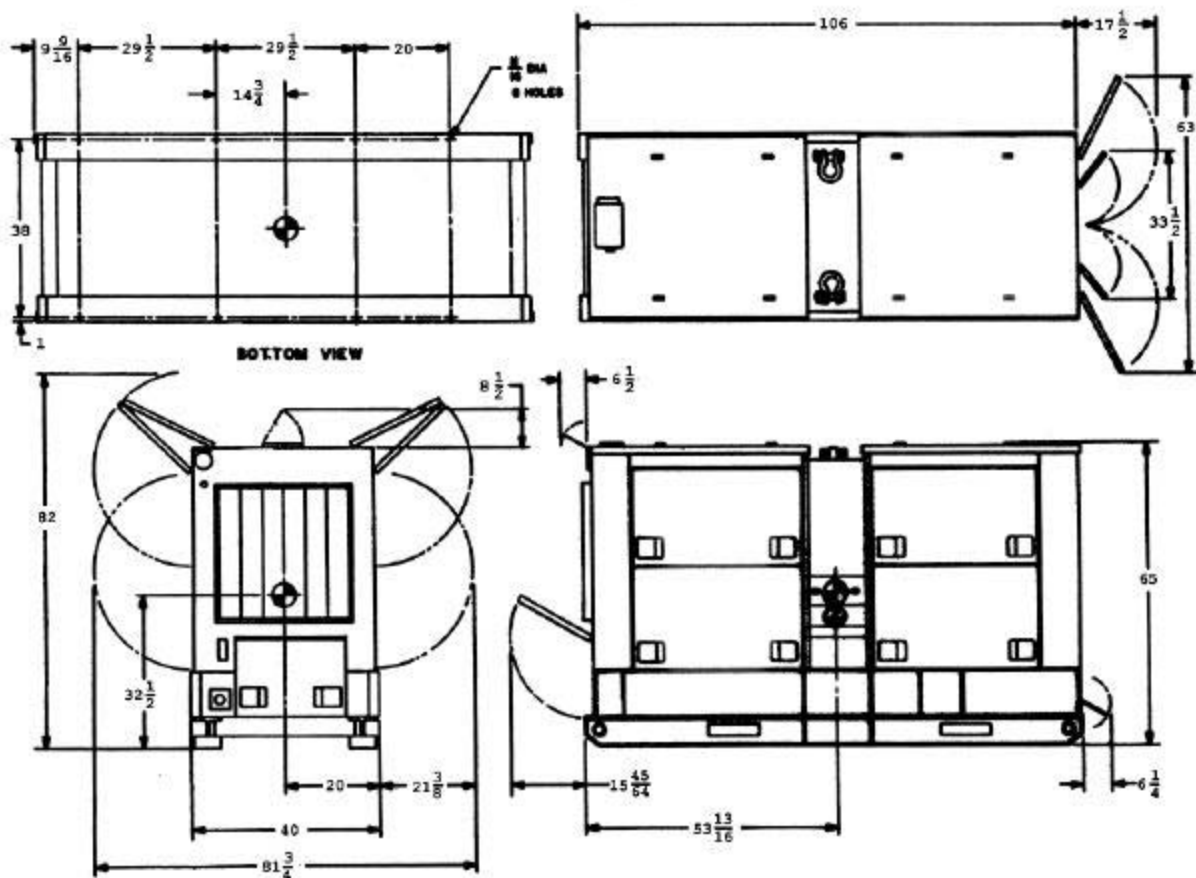
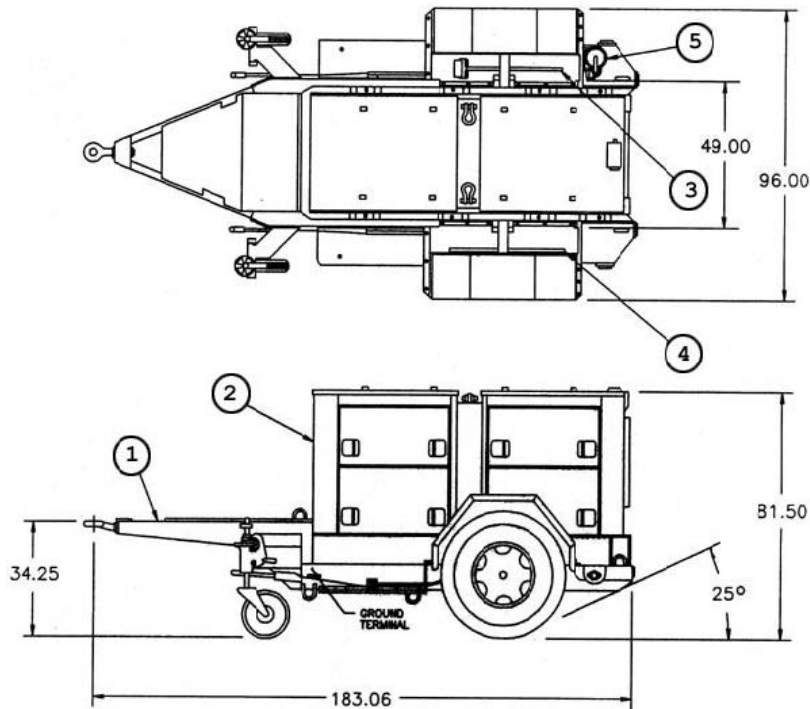

Figure E- 45 100 kW Diesel Engine Driven Generator

MIL-HDBK-633A  
APPENDIX E

PU-495B/G, POWER UNIT, DED, 100 kW, 50/60 Hz, TRLMTD

Identification Data					
Description	POWER UNIT, DED, 100 kW, 50/60 Hz, TRLMTD			Camouflage: 97403-13226E7490	
<b>Model</b>	<b>NSN</b>	<b>LIN</b>	<b>SSN</b>	<b>ASSEMBLY</b>	<b>SPEC</b>
PU-495B/G	6115-01-134-0165	J35801	M547	TA-13226E1340	not procurable
Physical Characteristics					
<b>Dimensions LWH (in) &amp; (Cube) (ft<sup>3</sup>)</b>	<b>Ship Cube (ft<sup>3</sup>)</b>		<b>Wet Weight (lbs)</b>	<b>Ship Weight (lbs)</b>	
183.1 x 96.0 x 81.5	855		10650	10400	



COMPONENT	QTY	FIND	IDENTIFIER
3-1/2 Ton modified Trailer, M353	1	1	97403-13220E6330
Generator set, DED, 100 kW, 50/60 Hz, MEP-007B	1	2	6115-01-036-6374
8 lb engineers hammer	1	3	5120-00-251-4489
Ground rod, 9 ft	1	4	5975-00-296-5324
Fire extinguisher, 5 lb., A-A-1106	1	5	4210-00-270-4512

Figure E- 46 PU-495B/G

**MIL-HDBK-633A  
APPENDIX E**

**200 kW, DED, Generator Set**

Identification Data				
Nomenclature	Gen Set, DED, 200 kW, 50/60 Hz		Gen Set, DED, 200kW, 50/60 Hz	
Model Number	MEP-009A		MEP-108A	
NSN	6115-00-133-9104		6115-00-935-9729	
LIN	J40158		J40150	
SSN	M504		M504	
TRLMTD Configuration	AN/MJQ11			
Physical Characteristics				
Dimensions LWH (in)	114 x 50 x 75 (247 ft3)		114 x 50 x 75 (247 ft3)	
Weight (lbs)	10260		10350	
Engine	6 cylinder Diesel, 344hp @ 1800RPM (60Hz), 296hp @ 1500RPM (50Hz), liquid cooled, 24Volt starter.			
Fuels	Diesel: DL-1, DL-2; Jet fuel: JP-8, Jet A-1.			
Fuel Tank	130 gal.			
Instrumentation	Hourmeter, voltmeter, frequency meter, ammeter, wattmeter, oil pressure, battery charge, fault indicating system, temp, fuel level.			
Performance Characteristics				
Electric Power Rating	200 kW, 60 Hz or 167 kW, 50 Hz @ 0.8 power factor from -25°F (-65°F with winterization kit) to 125°F/MSL, 107°F/5000 ft.			
Fuel Consumption	10 gph @ rated load		16 gph @ rated load	
Protective Devices	Overload, over voltage, short circuit, reverse power, low oil pressure, high temperature, low fuel, overspeed.			
Reliability (MTBF)	520 hr specified		480 hr specified	
Electrical Characteristics				
Connection	120/208V, 3 phase, 4 wire		240/416 V, 3 phase, 4 wire	
Operating Frequency	50 Hz	60 Hz	50 Hz	60 Hz
Voltage Adj Range	190 to 213	197 to 240	380 to 426	395 to 480
Electrical	Drip proof generator enclosure, fungus & moisture treated, solid state voltage regulator, brushless rotary alternator			
Electrical Performance				
Electric Power Quality	MEP-009A		MEP-108A	
	Volt	Frequency	Volt	Frequency
Regulation	3%	2-3% (adj)	1%	0.25%
Short term steady state stab (30 sec)	2%	2%	1%	0.5%
Long term steady state stab (4 hr)	4%	3%	2%	1%
Application/Rejection of rated load recovery time	20%/20%, 3 sec	3%/4%, 3 sec	15%/15%, 0.5 sec	4%/4%, 2 sec
Max waveform deviation factor	5%		5%	
Individual waveform harmonic	2%		2%	
Motor load	40% dip		30% dip	
Recovery	5 sec		0.7 sec	
EMI	Suppressed to MIL-STD-461 limits.:			
EMP	Not protected.			
Optional Equipment				
Description	NSN	Weight (lbs)	Effect on Dim.(in)	
Fuel burning winterization kit	6115-00-403-3761	85	internal	
Electrical winterization kit	6115-00-489-7285	45	internal	
Aux fuel burning winterization kit	6115-00-463-9098	350	41 x 40 x 26 (Aux)	
Aux electrical winterization kit	6115-00-463-9099	260	36 x 27 x 19 (Aux)	
Remote control box	6115-00-420-8490	8	Internal	
Load bank	6115-00-403-3762	580	H+23	
Auto load tranf panel, 60 Hz	6115-00-471-7932	825	44 x 19 x 42 (Aux)	
Paralleling cable, 009A	6140-00-197-4934	4	negligible	
Precise relay assembly, 009A	6115-00-199-1616		internal	
Technical Manuals				
Army	Air Force	Marine Corps	Navy	
TM5-6115-458-12	TO35C2-3-443-1	TM 07536A-12	NAFAC P-8-629-12	
TM5-6115-458-34	TO35C2-3-443-2	TM 07536A-35	NAFAC P-8-629-34	
TM5-6115-458-24P	TO35C2-3-443-4	SL-4-07536	NAFAC P-8-629-24P	

MIL-HDBK-633A  
APPENDIX E

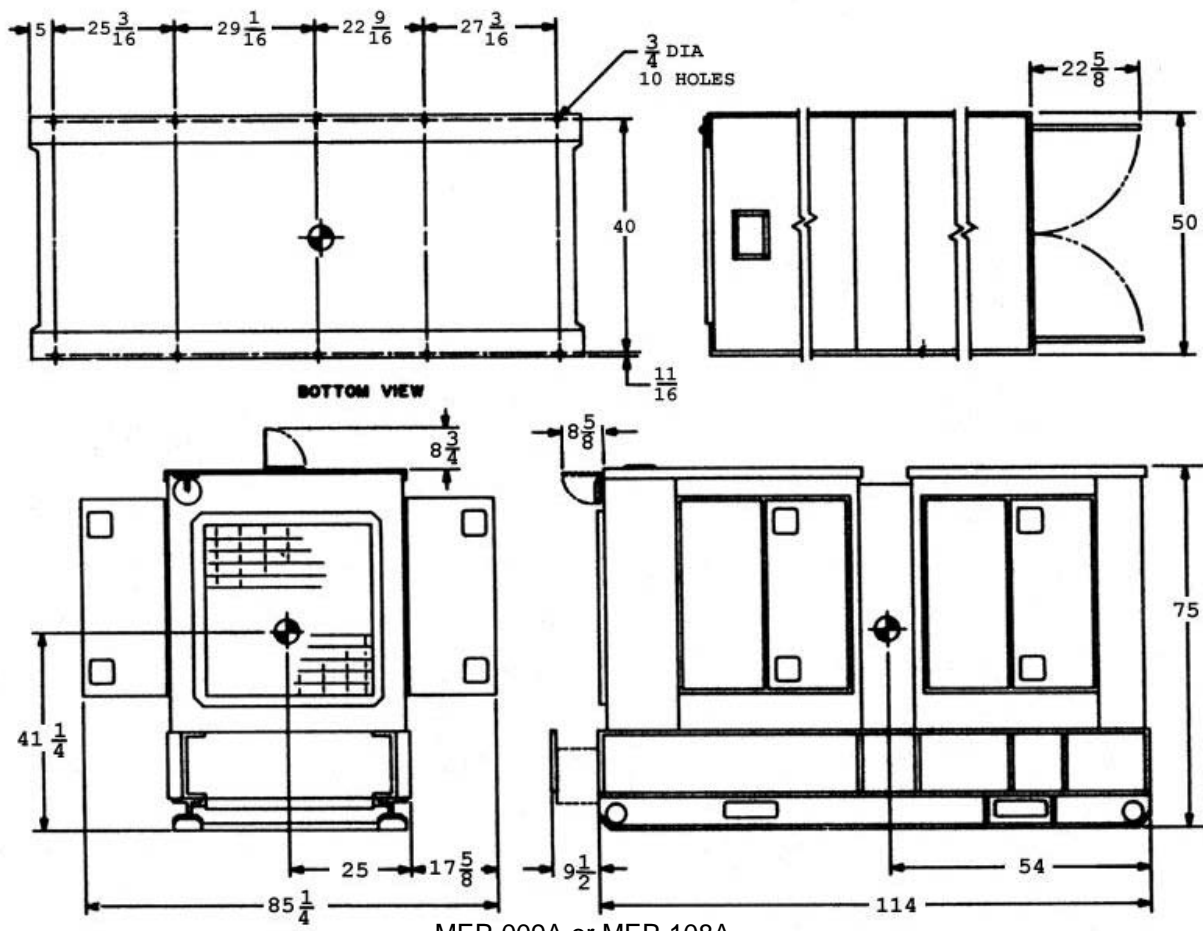

MEP-009A or MEP-108A

Figure E- 47 200 kW, DED, Generator Set

**MIL-HDBK-633A  
APPENDIX E**

**200 kW Diesel Engine Driven Generator**

Identification Data			
Nomenclature	Gen Set, 200 kW, DED, 50/60 Hz		
Model Number	MEP-009B		
NSN	6115-01-051-4096		
LIN	J40158		
SSN	M504		
TRLMTD Configuration	AN/MJQ-11A; <a href="#">Figure E- 49</a>		
Physical Data			
Dimensions LWH (in)	114 x 50 x 75 (Cube: 247 ft <sup>3</sup> )		
Weight (lbs)	Dry: 10500	Wet: 11500	
Engine	Diesel, 340 horsepower @ 1800 RPM (60 Hz), 290 horsepower @ 1500 RPM (50 Hz), 24 VDC starter, liquid cooled.		
Fuels	Diesel: DL-1, DL-2; Jet fuel: JP-8, Jet A-1.		
Fuel Tank	130 gallons		
Instrumentation	Hourmeter, voltmeter, frequency meter, ammeter, Wattmeter, oil pressure, coolant temperature, battery charging ammeter, fuel level and fault indication		
Performance Characteristics			
Electric Power Rating	200 kW, 60 Hz (167 kW, 50 Hz) @ 0.8 pf from -25°F (-65°F with winterization kit) to 125°F/MSL, 107°F/5000 ft.		
Environmental Capability	-25°F to 125°F, rain, humidity, altitude, sand/dust, transportation, -45°F cold storage, salt spray, fungus		
Protective Devices	Short circuit, overvoltage, overload, reverse power, low oil pressure, high temperature, low fuel, and overspeed		
Fuel Consumption	16 gal/hour		
Human Factors	MIL-STD-1474.		
Noise	93 dBA @ 25 ft.		
Reliability (MTBF)	468 hr specified		
Electrical Characteristics			
Connection	120/208V, 3 phase, 4 wire	240/416V, 3 phase, 4 wire	
Frequency	50 Hz	60 Hz	50 Hz      60 Hz
Voltage Adj Range	190 - 213	197 - 240	380 - 426      395 - 480
Electrical	Drip proof generator enclosure, fungus & moisture treated, solid state voltage regulator, solderless connectors, Brushless rotary exciter. Capable of parallel operation.		
EMI	Suppressed to MIL-STD-461 limits.		
EMP	Not protected		
Electrical Performance			
Electric Power Quality	Volt		Frequency
Regulation	1%		0.25%
Short term steady state stab (30 sec)	1% bandwidth		0.5% bandwidth
Long term steady state stab (4 hr)	2% bandwidth		1% bandwidth
Applic./Rejec. of rated load/recovery time	15%, 0.5 sec		4%, 2 sec
Max waveform deviation factor	5%		
Individual waveform harmonic	2%		
Motor load	30% dip, 0.7 sec recov		
Optional Equipment			
Description	NSN	Weight (lbs)	Effect on Dim.
Fuel burning winterization kit	6115-01-xxx-xxxx		internal
Electrical winterization kit	6115-01-xxx-xxxx		internal
Wheel kit	2530-01-221-8306	8	H+
Technical Manuals			
Army	Air Force	Marine Corps	Navy
TM5-6115-614-12	TO35C2-3-443-1	TM 07536A-12	NAVFAC P-8-645-12
TM5-6115-614-34	TO35C2-3-443-2	TM 07536A-35	NAVFAC P-8-645-34
TM5-6115-614-24P	TO35C2-3-443-14	SL-4-07536-25B	NAVFAC P-8-645-24P

MIL-HDBK-633A  
APPENDIX E

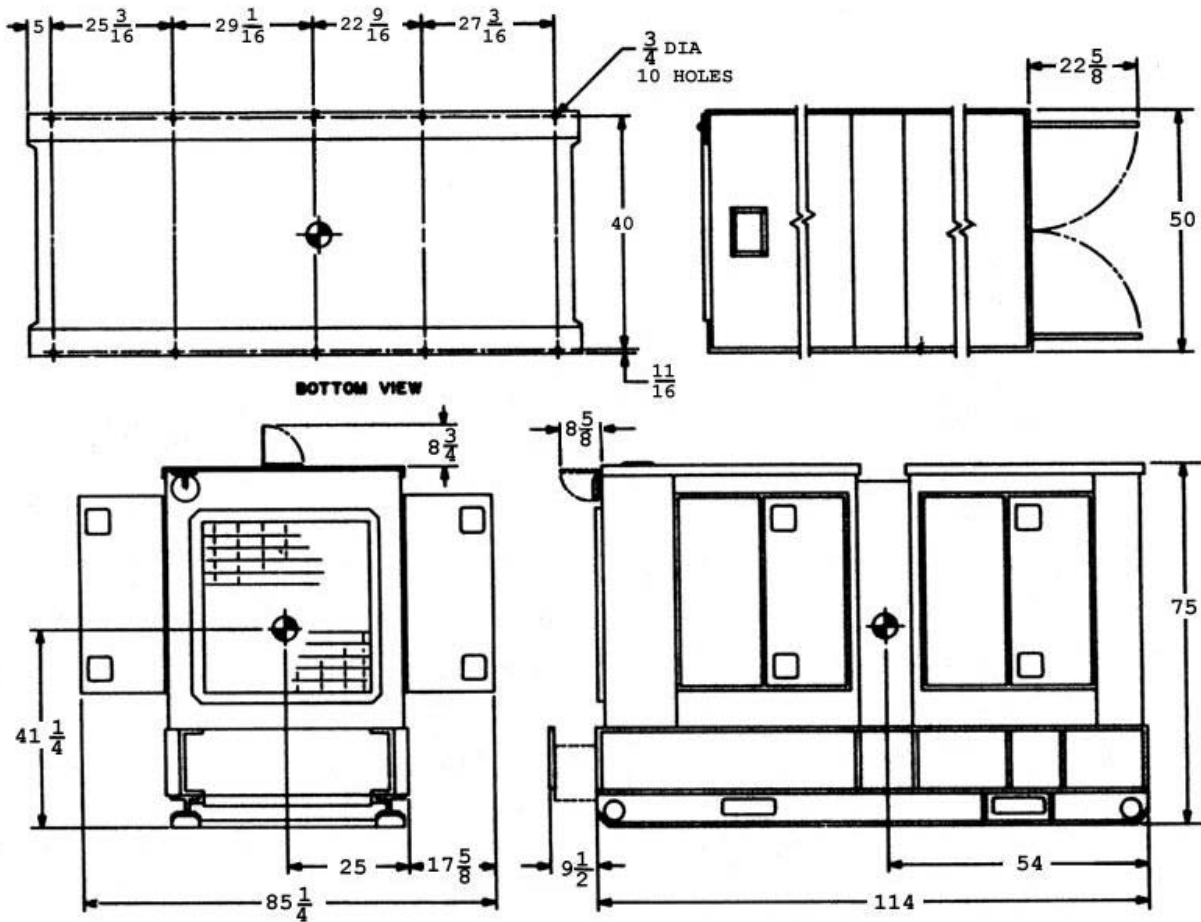

MEP-009B

Figure E- 48 200 kW Diesel Engine Driven Generator

MIL-HDBK-633A  
APPENDIX E

PP-AN/MJQ-11\* POWER PLANT, DED, 200 kW, 50/60 Hz, TRLMTD

Identification Data					
Description	POWER PLANT, DED, 200 kW, 50/60 Hz, TRLMTD			Camouflage:	
Model	NSN	LIN	SSN	ASSEMBLY	SPEC
PP-AN/MJQ-11*	6115-00-134-8485	P27821	M527	TA-13220E6338	not procurable
Physical Characteristics					
Dimensions LWH (in) & (Cube) (ft <sup>3</sup> )		Ship Cube (ft <sup>3</sup> )		Wet Weight (lbs)	Ship Weight (lbs)
348 x 96 x 103 & (1991)(each unit)		1991 (each unit)		Unit A: 20740 Unit B: 20000	Unit A: 19920 Unit B: 19160

\* PP-AN/MJQ-11A, NSN 6115-00-394-9585, uses MEP-009B in lieu of MEP-009A

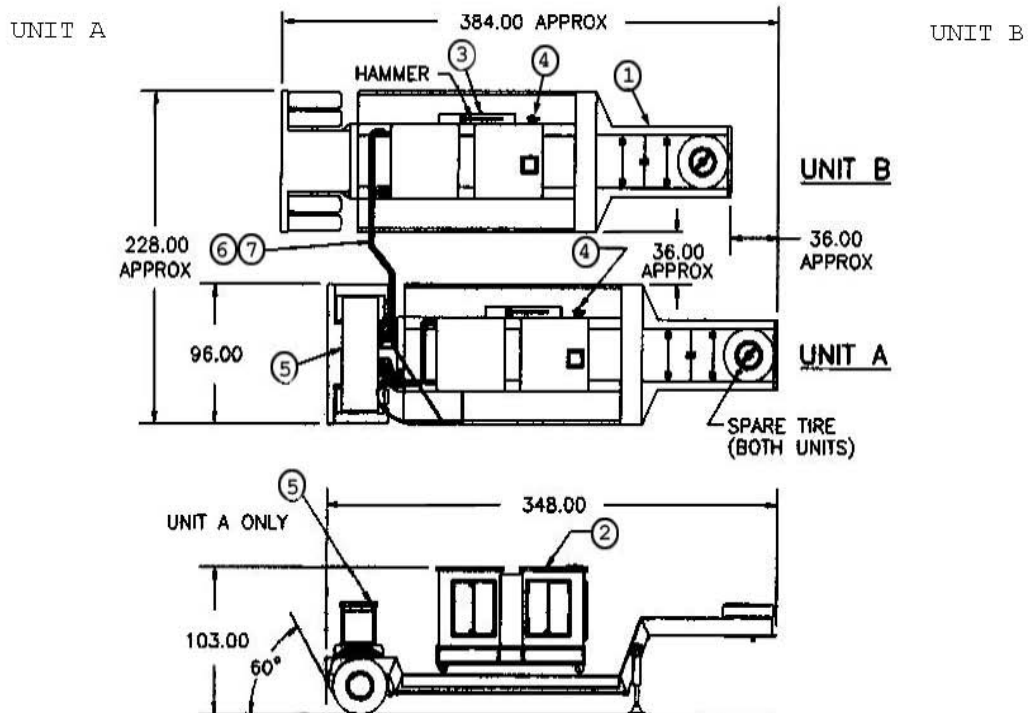

COMPONENT	QTY	FIND	IDENTIFIER
Semi trailer, commercial	2	1	
Generator set, DED, 200 kW, 50/60 Hz, MEP-009A or MEP-009B (in PP-AN/MJQ-11A)	2	2	6115-01-051-4096 6115-00-133-9104
Accessory box	2	3	
Fire extinguisher, 5 lb., A-A-1106	2	4	4210-00-270-4512
Distribution box (unit A)	1	5	97403-13226E2180
Cable assembly	1	6	97403-13218E5088
Cable assembly	1	7	97403-13218E5089

Figure E- 49 AN/MJQ-11A



**MIL-HDBK-633A  
APPENDIX E**

**500 kW Diesel Engine Driven Generator**

Identification Data			
Nomenclature	Gen Set, 500 kW, DED, 50/60 Hz		
Model Number	MEP-029A	MEP-029B	
NSN	6115-01-030-6085	6115-01-318-6302	
LIN	G40424		
SSN	M577		
Physical Characteristics			
Dimensions LWH (in)	219 x 88 x 120 (Cube: 1338 ft <sup>3</sup> )		
Weight (lbs)	Dry: 32550 ;	Wet: 34050	
Engine	12 cylinder Diesel, 830 horsepower @ 1800 RPM (60 Hz), 690 horsepower @ 1500 RPM (50 Hz), 24 VDC starter, liquid cooled.		
Fuels	Diesel: DL-1, DL-2. Emergency: Jet fuel: JP-8, Jet A-1.		
Fuel Tank	117 gallons.		
Instrumentation	Voltmeter, frequency meter, ammeter, hourmeter, kilowattmeter, oil pressure, oil temperature, coolant temperature, battery charging ammeter, fuel level, 50/60 Hz clock.		
Performance Characteristics			
Electric Power Rating	500 kW, 60 Hz (417 kW, 50 Hz) @ 0.8 pf from 3°F to 125°F/ MSL; 400 kW(334 kW) @ 0.8 pf to 107°F/5000 ft; 375 kW(313 kW) @ 0.8 pf to 95°F/8000 ft. Housing kit and built in electric engine preheat system extends lower temperature limit to -25°F.		
Environmental Capability	32°F to 125°F, rain, humidity, altitude, sand/ dust, transportation, -65°F cold storage, salt spray, fungus.		
Protective Devices	Overvoltage, short circuit, overload synchronizing check relay, reverse power, low oil pressure, high coolant temp, high oil temp, low fuel, and overspeed, annunciator alarm System		
Fuel Consumption	37 gal/hour		
Human Factors	MIL-STD-1474.		
Noise	Housed:86 dBA @ 25 ft.	Unhoused: 89 dBA @ 25 ft.	
Reliability (MTBF)	500 hr (specified).		
Electrical Characteristics			
Voltage Connection	120/208V, 3 phase, 4 wire	240/416V, 3 phase, 4 wire	
Operating Frequency	50 Hz	60 Hz	50 Hz      60 Hz
Volt Adj Range	190 to 213	197 to 250	380 to 426      395 to 500
Electrical	Drip proof generator enclosure, fungus & moisture treated, solid state voltage regulator, solderless connectors, Brushless rotary exciter. Capable of parallel operation. Circuit breaker.		
Electrical Performance			
Electric Power Quality	Volt		Frequency
Short term steady state stab (30 sec)	1% bandwidth		0.5% bandwidth
Long term steady state stab (4 hr)	2% bandwidth		1% bandwidth
Application/rejection of rated load, recovery time	20%dip/30%rise, 3 sec		4%, 4 sec
Max waveform deviation factor	5%		
Individual waveform harmonic	2%		
Regulation	2%		0.25% isoc; 0-3% adj
EMI	Suppressed to MIL-STD-461 limits.		
EMP	None.		
Optional Equipment			
Description	NSN	Weight (lbs)	Effect on Dim.(in)
Housing kit	6115-01-070-7550	1950	negligible
Remote control module	6115-01-070-7553	371	33.8x23.5x58.8 (Aux)
Auto control module	6115-01-275-7912	267	30.8x13.3x66.4 (Aux)
Remote control cable	6115-01-087-4127	150	None. Cable is 1000 ft
Technical Manuals			
Army	Air Force	Marine Corps	Navy
TM5-6115-593-12	TO-35C2-3-463-1		
TM5-6115-593-34	TO-35C2-3-463-2		
TM5-6115-593-24P	TO-35C2-3-463-4		

MIL-HDBK-633A  
APPENDIX E

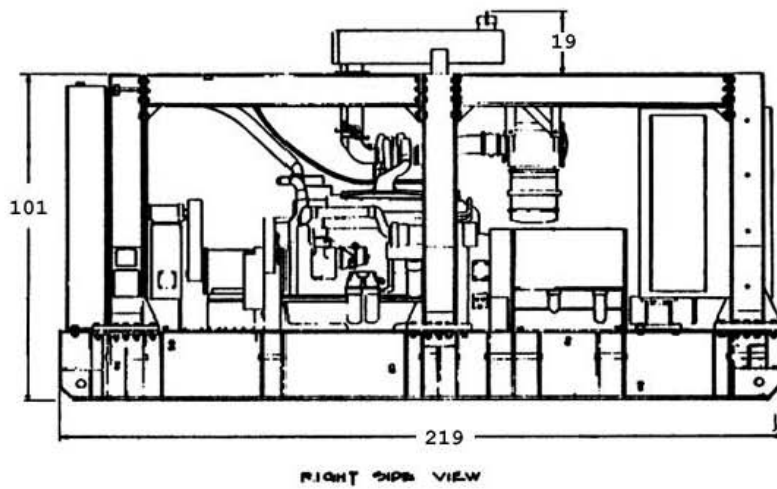
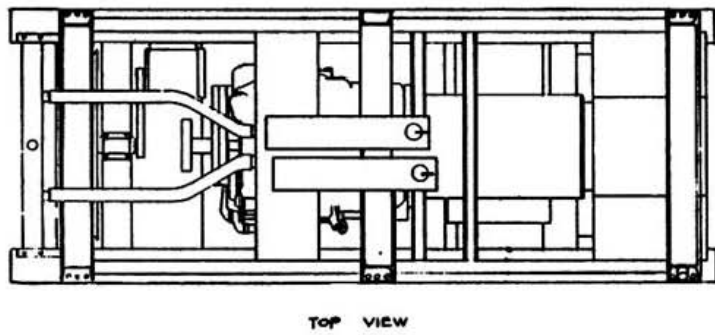
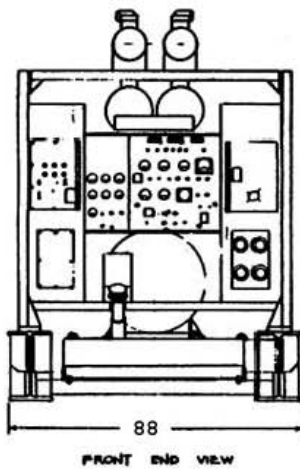
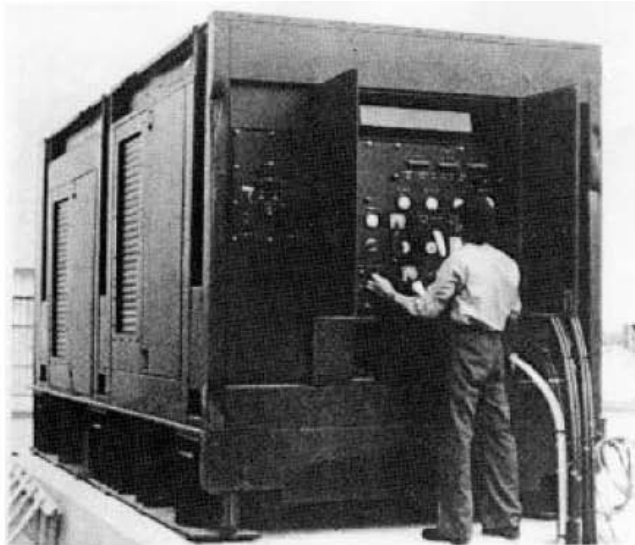

Figure E- 50 500 kW DED Generator, MEP-029A, MEP-029B

**MIL-HDBK-633A  
APPENDIX E**

**750 kW Diesel Engine Driven Generator**

<b>Identification Data</b>			
Nomenclature	Gen Set, 750 kW, DED, 50/60 Hz, Prime Power, Housed, Wheel Mounted		
Model Number	MEP-012A		
NSN	6115-00-143-3850		
LIN	J		
SSN	M		
<b>Physical Characteristics</b>			
Dimensions LWH (in)	241 x 96 x 101 (Cube:1353 ft <sup>3</sup> )		
Weight (lbs)	Dry: 24500	Wet : 25374	
Engine	12 cylinder, turbocharged Diesel, 1235 hp @ 1800 RPM (60 Hz), 1030 hp @ 1500 RPM (50 Hz), liquid cooled, 24 VDC starter.		
Fuels	Diesel: DL-1, DL-2. Emergency: Jet fuel: JP-8, Jet A-1.		
Fuel Tank	42 gallons.		
Instrumentation	Voltmeter, frequency meter, ammeter, hourmeter, kilowattmeter, oil pressure, oil temperature, coolant temperature, battery charging ammeter, fuel level, 50/60 Hz clock.		
<b>Performance Characteristics</b>			
Electric Power Rating	750 kW, 60 Hz (625 kW, 50 Hz) @ 0.8 pf from -25°F to 125°F/MSL, 90°F/1500 ft; 600 kW(500 kW) to 107°F/5000 ft.		
Environmental Capability	-25°F to 125°F, rain, humidity, altitude, sand/ dust, transportation, -65°F cold storage, salt spray, fungus.		
Mobility:	Maximum speed: 10 MPH on unimproved/20 MPH on improved roads.		
Protective Devices	Overvoltage, short circuit, overload synchronizing check relay, reverse power, low oil pressure, high coolant temp, high oil temp, low fuel, and overspeed, annunciator alarm System.		
Fuel Consumption	55 gal/hour.		
Human Factors	MIL-STD-1474.		
Noise Housed:	85 dBA @ 25 ft.		
<b>Electrical Characteristics</b>			
Connection	2200/3800V, 3 phase, 4 wire	2400/4160V, 3 phase, 4 wire	
Frequency	50 Hz	60 Hz	
Voltage Adj Range	3240 to 3960	3745 to 4574	
Electrical	Drip proof generator enclosure, fungus & moisture treated, solid state voltage regulator, solderless connectors, Brushless rotary exciter. Capable of parallel operation. Circuit breaker.		
<b>Electrical performance</b>			
<b>Electric Power Quality</b>	<b>Volt</b>	<b>Frequency</b>	
Regulation	2%	0-5% adjustable	
Short term steady state stability (30 sec)	1%	0.5%	
Long term steady state stability (4 hr)	2%	1%	
Application/Rejection of rated load, recovery time	20%dip/rise; 3 sec	3%dip/4%rise 4 sec	
Max waveform deviation factor	5%		
Individual waveform harmonic	2%		
EMI	Suppressed to MIL-STD-461 limits.		
EMP	Not protected		
<b>Optional Equipment:</b>			
none			
<b>Technical Manuals</b>			
<b>Army</b>	<b>Air Force</b>	<b>Marine Corps</b>	<b>Navy</b>
TM9-6115-622-12	TO35C2-3-474-1	TM6115-12/10	NAVFAC P8-635-12
TM9-6115-622-34	TO35C2-3-474-2	TM6115-34/	NAVFAC P8-635-34
TM9-6115-622-24P	TO35C2-3-474-4	TM6115-24/	NAVFAC P8-635-24P

MIL-HDBK-633A  
APPENDIX E

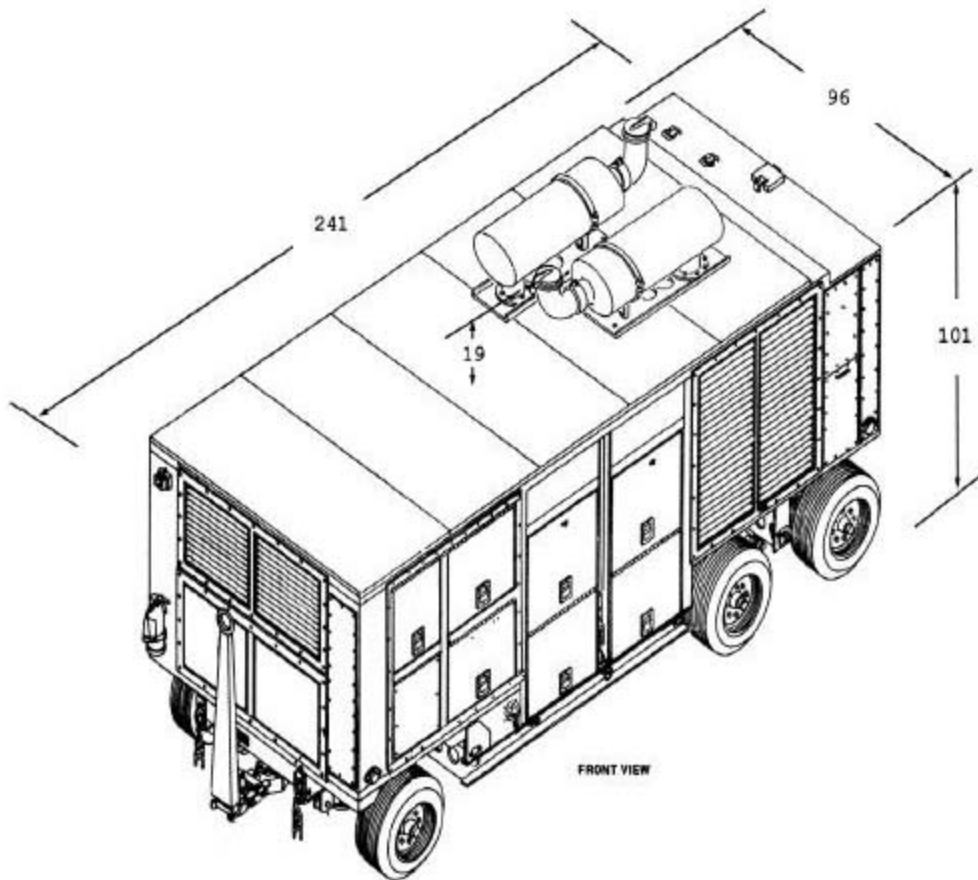

Figure E- 51 750 kW DED Generator, MEP-012A

**MIL-HDBK-633A  
APPENDIX E**

**750 kW Diesel Engine Driven Generator Set**

<b>Identification Data</b>			
Nomenclature	Gen Set, 750 kW, DED, 50/60 Hz, Housed, Prime Power		
Model Number	MEP-208A		
NSN	6115-00-450-5881		
LIN	J30093		
SSN	M564		
<b>Physical Characteristics</b>			
Dimensions LWH (in)	330 x 96 x 100 (with 24 ft <sup>2</sup> control room)(Cube: 1850 ft <sup>3</sup> )		
Wet Weight (lbs)	39600		
Engine	12 cylinder, turbocharged Diesel, 1235 hp @ 1800 RPM (60 Hz), 1030 hp @ 1500 RPM (50 Hz), liquid cooled, 24 VDC starter.		
Fuels	Diesel:DL-1, DL-2; Jet fuel: JP-8, Jet A-1		
Fuel Tank	134 gallons..		
Instrumentation	Voltmeter, frequency meter, ammeter, hourmeter, kilowattmeter, oil pressure, oil temperature, coolant temperature, battery charging ammeter, fuel level, 50/60 Hz clock		
<b>Performance Characteristics</b>			
Electric Power Rating	750 kW 60 Hz (625 kW, 50 Hz) @ 0.8 pf from 25°F to 125°F/MSL, 90°F/1500 ft; 600 kW(500 kW) to 107°F/5000 ft; 563 kW(469 kW) to 95°F/8000 ft.		
Environmental Capability	-25°F to 125°F, rain, humidity, altitude, sand/ dust, transportation, -65°F cold storage, salt spray, fungus.		
Protective Devices	Overvoltage, short circuit, overload synchronizing check relay, reverse power, low oil pressure, high coolant temp, high oil temp, low fuel, and overspeed, annunciator alarm system.		
Fuel Consumption	55 gal/hour		
Human Factors	MIL-STD-1474.		
Noise	85 dBA @ 25 ft, housed (89 dBA unhoused).		
Reliability (MTBF)	1200 hr (specified).		
<b>Electrical Characteristics</b>			
Connection	2200/3800V, 3 phase, 4 wire	2400/4160V, 3 phase, 4 wire	
Frequency	50 Hz	60 Hz	
Voltage Adj Range	3240 To 3960	3745 To 4574	
Frequency Adj Range	48 - 52	58 - 62	
Electrical	Drip proof generator enclosure, fungus & moisture treated, solid state voltage regulator, solderless connectors, Brushless rotary exciter. Capable of parallel operation. Circuit breaker.		
<b>Electrical Performance</b>			
<b>Electric Power Quality</b>	<b>Volt</b>	<b>Frequency</b>	
Regulation	2%	0-5% adjustable	
Short term steady state stab (30 sec)	1%	0.5%	
Long term steady state stab (4 hr)	2%	1%	
Application/Rejection of rated load, recovery time	20%dip/30%rise, 3 sec	3%dip/4%rise, 4 sec	
Max waveform deviation factor	5%		
Individual waveform harmonic	2%		
EMI	Suppressed to MIL-STD-461 limits.		
EMP	None.		
<b>Optional Equipment</b>			
<b>Description</b>	<b>NSN</b>	<b>Weight-lb</b>	<b>Effect on Dim.(in)</b>
Remote control module	6115-00-xxx-xxxx	371	stored in control room
Remote control cable	6115-00-xxx-xxxx	150	None-Cable is 1000 ft
<b>Technical Manuals</b>			
<b>Army</b>	<b>Air Force</b>	<b>Marine Corps</b>	<b>Navy</b>
TM9-6115-604-12			NAVFAC P-8-633-12
TM9-6115-604-34			NAVFAC P-8-633-34

MIL-HDBK-633A  
APPENDIX E

TM9-6115-60424P

NAVFAC P-8-633-24P

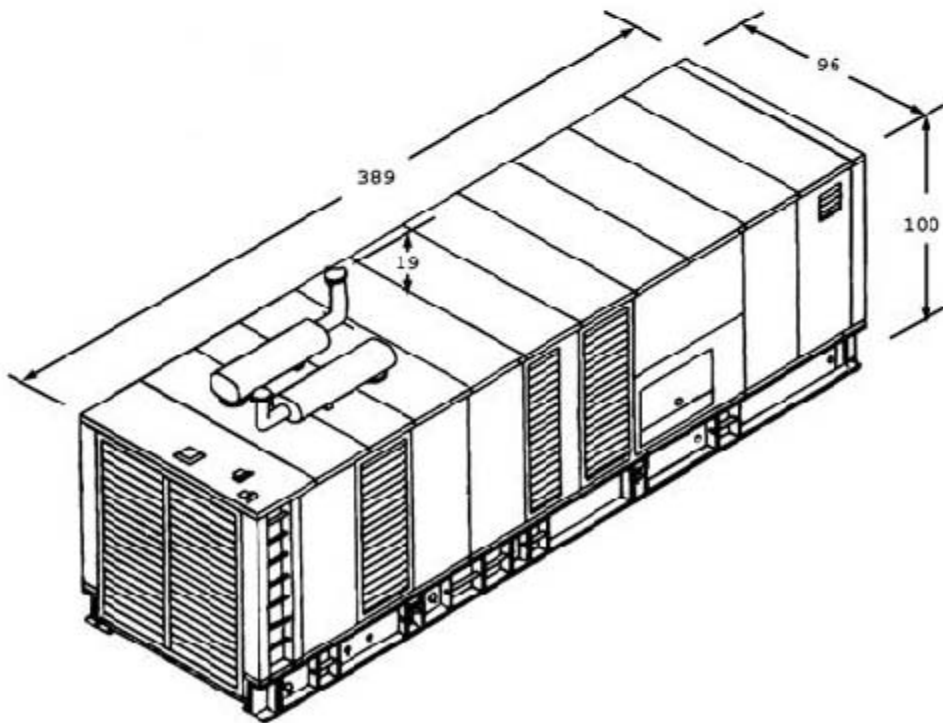
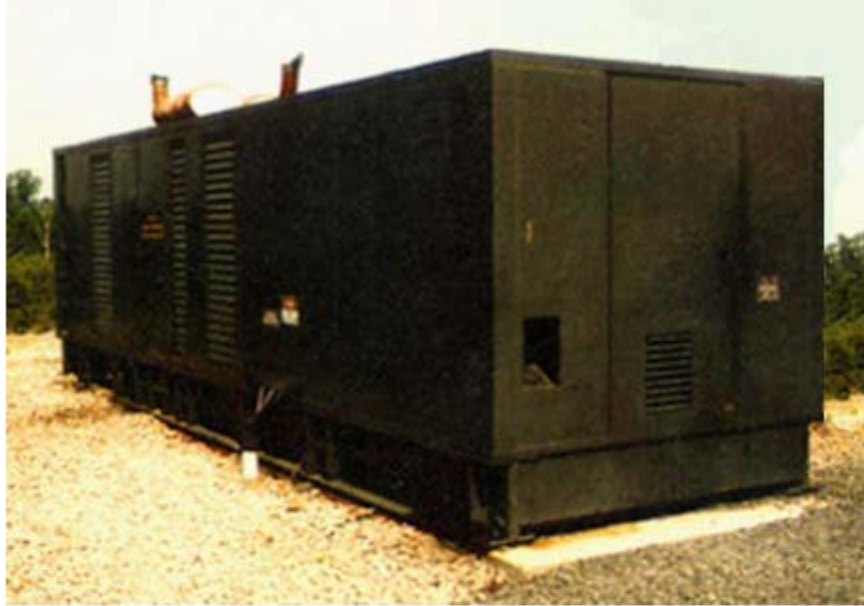

Figure E- 52 750 kW DED Generator, MEP-208A

**MIL-HDBK-633A**  
CONCLUDING MATERIAL

Custodians:  
Army-CR4  
Navy-YD  
Air Force-99

Preparing activity  
ARMY-CR4  
(Project 6115-2009-003)

Review Activities:  
Army - CE,MI,  
NAVY-AS,EC,MC  
Air Force -11  
DLA - GS

NOTE: These activities listed above were interested in this document as of the date of this document. Since organizations and responsibilities can change, you should verify the currency of the information above using the ASSIST database at: <http://assist.daps.dla.mil>.