

**INOVA HIGHTECH Ltd.**

**MEP 804A/B Auto Starter  
Wiring Supplement**

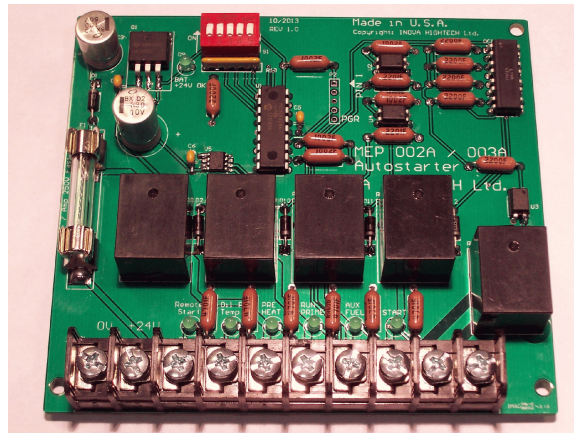

Wiring Instructions  
for the  
MEP 002/003 Auto / Remote Starter  
for the following MEP Power Generators:

**MEP 804A/B / 814A/B**

## **Index**

<b><i>Index</i></b>	<b>1</b>
<b><i>DIP Switch Functions</i></b>	<b>2</b>
<b><i>Wiring Guide</i></b>	<b>3</b>
<b><i>Modified DC Wiring Diagram with Relay K ext.</i></b>	<b>4</b>
<b><i>G and X Wiring Diagram</i></b>	<b>5</b>
<b><i>Suggested mounting Location for the Auto Start Kit PCB</i></b>	<b>6</b>
<b><i>Example of 2 Amphenol Connectors for remote wiring connection</i></b>	<b>7</b>

## ***INOVA HIGHTECH Ltd.***

*15115 Chestnut Street  
Basehor, KS 66007  
U.S.A.*

*Tel: (913) 728 2662*

*Web Site: <http://www.inovahightech.com>*

*E-Mail: [Sales@inovahightech.com](mailto:Sales@inovahightech.com)*

**© 2015 INOVA HIGHTECH Ltd.**

The Autostarter Board KIT for the MEP 804 A/B is the same as for the 002A/003A

*Except that the 804 A/B version has a different Software loaded!*

The 804 A/B Software affects/changes the following functions / Terminal Nomenclature:

1. Dip Switch Functions, Settings and Timing
2. Different Connections between the Board and the Cubicle
3. Fixed Pre Heat of 30 sec or OFF
4. No ambient temperature dependent timing
5. The Oil P / TEMP Input will now additionally monitor Over Voltage and Low Fuel, besides Oil Pressure and Over Temperature
6. When the Software goes from START to RUN Cycle and the Engine Starts up properly and the Oil Pressure is over 20 PSI then both **LED's OIL P** will illuminate and stay **On** until the Unit shuts off!

All other instructions from the MEP 002A/003A Manual apply for these Gen Sets as well

<b>DIP Switch Settings 804 A/B</b>			
<b>DIP SWITCH</b>	<b>Function</b>	<b>DIP SWITCH ON POSITION</b>	<b>DIP SWITCH OFF POSITION</b>
<b>1</b>	<b>AUX FUEL</b>	ON	OFF
<b>2</b>	<b>PRIME + AUX Fuel</b>	15 sec	OFF
<b>3</b>	<b>PRE HEAT GLOW PLUGS</b>	30 sec	OFF

<b>Warm Up and Cool Down Matrix</b>			
<b>DIP SWITCH 4</b>	<b>DIP SWITCH 5</b>	<b>WARM UP</b>	<b>COOL DOWN</b>
<b>OFF</b>	<b>OFF</b>	0 sec	1 Min
<b>OFF</b>	<b>ON</b>	15 sec	2 Min
<b>ON</b>	<b>OFF</b>	30 sec	3 Min
<b>ON</b>	<b>ON</b>	45 sec	5 Min

## Wiring Connections between Control Cubicle Panel Switch S1, S2, TB4, TB5, TB6, A1 - GND Stud and Auto-starter TB

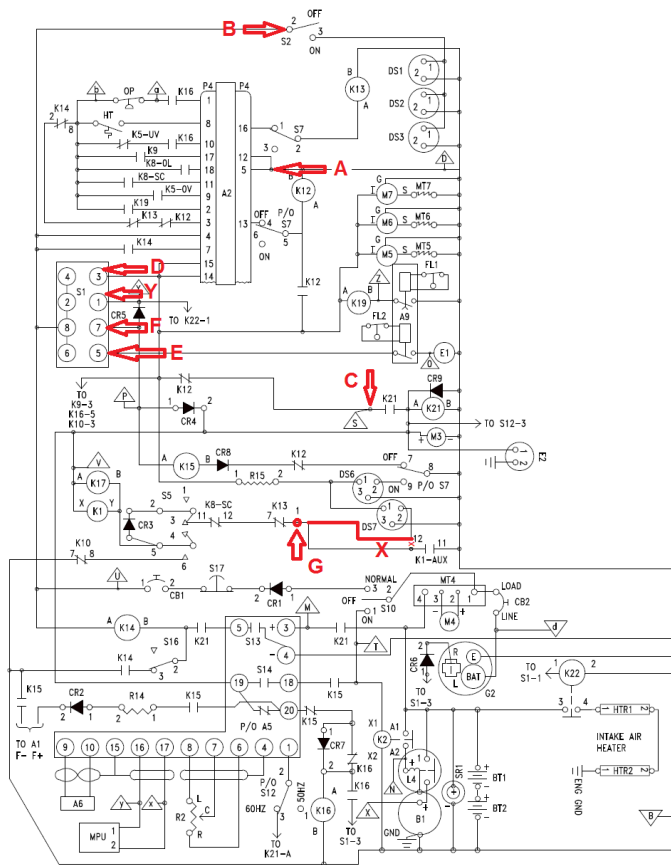

**G and X:** Please see wiring diagram on next page

FROM	TO
Control Cubicle with S 1, S2, A1, TB 4, TB 5, TB 6	Autostarter TB Label Number
<b>A</b> A1 - GND Stud see pic below	0V TB #1
<b>B</b> S 2 - 2	+24V TB #2
Please see Installation Manual MEP002A /003A	Remote Start TB #3
<b>C</b> TB5 - 17	Oil P / Temp TB #4
<b>Y</b> TB5 - 9	Pre Heat TB #5
<b>D</b> TB4 - 10	Run / Prime TB #6
<b>E</b> S 1 - 5	AUX Fuel TB #7
<b>F</b> TB6 - 8	Start TB #8
<b>Jumper</b> Jumper to TB #1 GND	COM TB #9
<b>See wiring diagram next page</b> Relay K Ext.	NO TB #10
TB = Terminal Block	





# Modified DC Wiring Diagram with Relay K ext. MEP 804A/B

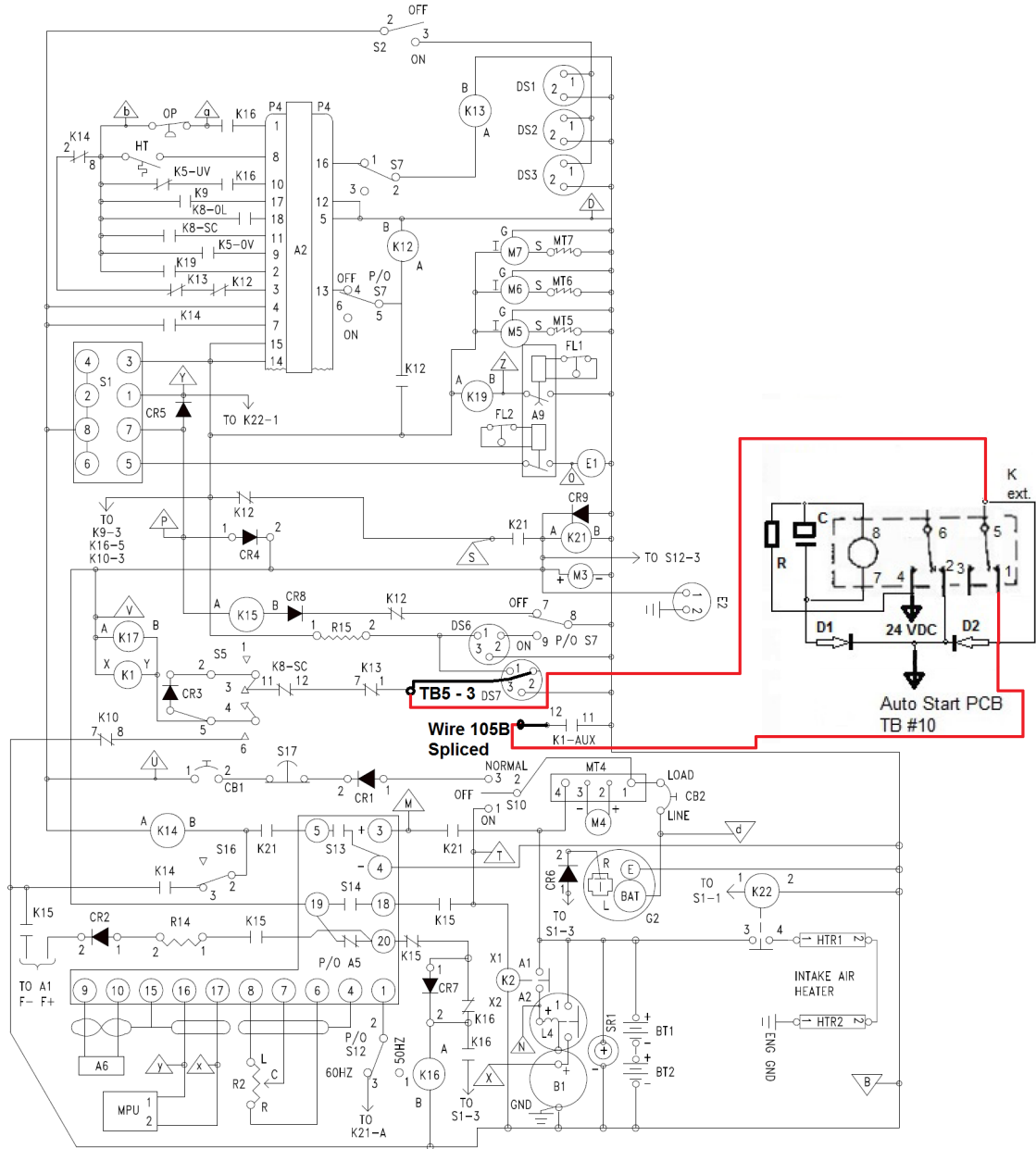

## G and X Wiring Diagram

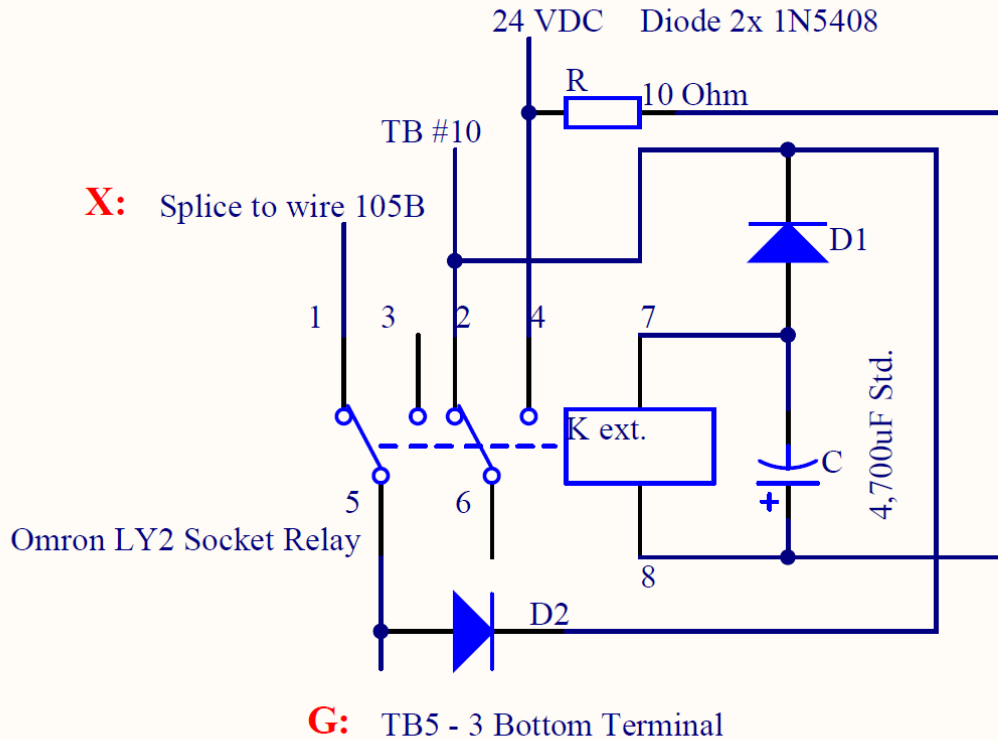

We recommend to proceed as follows:

1. Mount the supplied external Omron Relay [ Relay K ext. ] next to the Auto Start PCB by drilling two holes and securing the Socket with the supplied Stainless Steel Screws and K Lock Nuts or mount additional DIN Rail.
2. There are three existing wires on TB5 - 3: Two on the Top Terminal and One on the Bottom Terminal
3. Remove the Wire 105B from TB5 - 3 Bottom Terminal and extend this wire through the main wiring harness to Terminal 1 of Relay K ext. by the means of making a secure splice, which is mechanically stable and electrically fully insulated. We would recommend to use the "extension wire" with a ring lug and make the splice with a short #8 x 1/4" Stainless Steel Machine Screw with a K Lock Nut on the Ring Lug. Use Shrink Tubing or electrical tape!
4. Run a new wire from TB5 - 3 through the main wiring harness to Terminal 5 on Relay K ext.
5. Run a wire from Terminal 4 on Relay K ext. to TB #2 24 VDC
6. Run a wire from Terminal 2 on Relay K ext. to TB #10 on the Auto Start PCB
7. Make a long jumper wire and connect TB #9 to TB #1 or A1 - GND Stud on the Auto Start PCB

*Note: The Relay Coil of Relay K ext. is polarized! Terminal 8 is positive and Terminal 7 is negative or 0 Volt / GND. The Relay has a protection Diode to prevent damage in case of reversed polarity.*

## Suggested mounting Location for the Auto Start Kit PCB

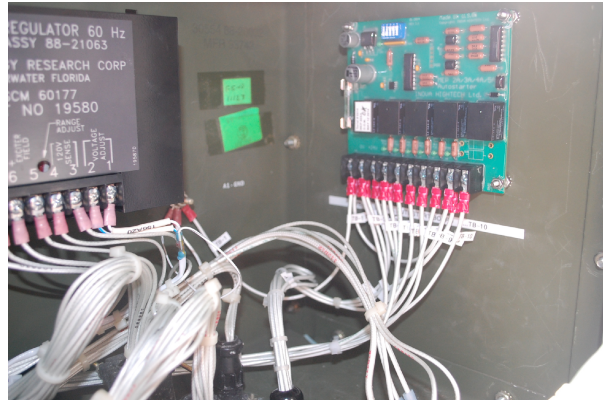

## Example of 2 Connectors for remote wiring connection

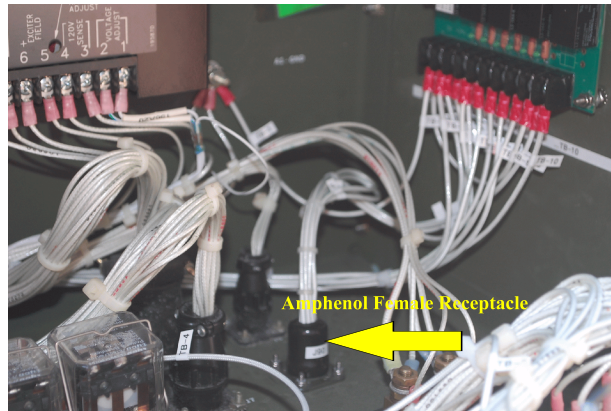

The first Amphenol Receptacle is mounted in the bottom of the Control Cubicle and wired with the Auto Starter PCB



The Connector connects to the Receptacle on the bottom of the Control Cubicle and has an other receptacle on the other end mounted on the side wall of the unit



Exit point of the remote connection

Parts needed:

1 pcs Female Receptacle; 1 pcs Male Receptacle; 1 pcs Female Connector Straight; 1 pcs Male Connector 90° angled -  
minimum are two wires for +24 VDC and Input TB #3 which are switched externally

All Pictures are courtesy of Steve Marquess, Maryland